

TECHNICAL MANUAL

**OPERATOR'S ORGANIZATIONAL,
DIRECT SUPPORT, AND
GENERAL SUPPORT
MAINTENANCE MANUAL**

**SPECTRUM ANALYZER
HEWLETT-PACKARD MODEL 85558B**



5

SAFETY STEPS TO FOLLOW IF SOMEONE IS THE VICTIM OF ELECTRICAL SHOCK

1

DO NOT TRY TO PULL OR GRAB THE INDIVIDUAL

2

IF POSSIBLE, TURN OFF THE ELECTRICAL POWER

3

IF YOU CANNOT TURN OFF THE ELECTRICAL POWER, PULL, PUSH OR LIFT THE PERSON TO SAFETY USING A DRY WOODEN POLE OR A DRY ROPE OR SOME OTHER INSULATING MATERIAL

4

SEND FOR HELP AS SOON AS POSSIBLE

5

AFTER THE INJURED PERSON IS FREE OF CONTACT WITH THE SOURCE OF ELECTRICAL SHOCK, MOVE THE PERSON A SHORT DISTANCE AWAY AND IMMEDIATELY START ARTIFICIAL RESUSCITATION

SAFETY CONSIDERATIONS Safety Symbols

The following safety symbols are used throughout this manual and in the instrument. Familiarize yourself with each of the symbols and its meaning before operating this instrument.



Instruction manual symbol: the apparatus will be marked with this symbol when it is necessary for the user to refer to the instruction manual in order to protect the apparatus against damage.

the equipment. Do not proceed beyond a CAUTION sign until the indicated conditions are fully understood and met.



Indicates dangerous voltages.



The WARNING sign denotes a hazard. It calls attention to a procedure, practice, or the like, which, if not correctly performed or adhered to, could result in injury or loss of life. Do not proceed beyond a WARNING sign until the indicated conditions are fully understood and met.

CAUTION The CAUTION sign denotes a hazard. It calls attention to an operation procedure, practice, or the like, which, if not correctly performed or adhered to, could result in damage to or destruction of part or all of

Operation



BEFORE THIS INSTRUMENT IS SWITCHED ON, the oscilloscope mainframe protective earth terminal must be connected through the protective conductor of the ac power cable to a socket outlet provided with protective earth contact. Failure to ground the instrument can result in personal injury.

performance tests, and service procedures which require operation of the 8558B out of the mainframe should be performed only by trained service personnel.

CAUTION

BEFORE THIS INSTRUMENT IS SWITCHED ON, make sure that the oscilloscope mainframe is set to the voltage of the ac power source. Failure to set the ac power input to the correct voltage could cause damage to the instrument when the ac power cable is plugged in.



The 8558B Spectrum Analyzer should not be operated without protective covers (out of the mainframe). Adjustments,

Service and Adjustments



There are voltages at many points in the instrument which can, if contacted, cause personal injury. Be extremely careful. Service and adjustments should be performed only by trained service personnel.



Any interruption of the protective (grounding) conductor, inside or outside the instrument, or disconnection of the protective earth terminal may cause personal injury.

This manual contains copyright material reproduced by permission of the Hewlett-Packard Company, Valley Forge, PA 19482.

TM 11-6625-3061-14

Technical Manual)
)
No. 11-6625-3061-14)

HEADQUARTERS
DEPARTMENT OF THE ARMY
Washington, DC, 1 January 1986

OPERATOR'S ORGANIZATIONAL AND
DIRECT SUPPORT, AND GENERAL SUPPORT
MAINTENANCE MANUAL
SPECTRUM ANALYZER HEWLETT-PACKARD MODEL 8558B
(Includes Option 001 and Option 002)

SERIAL NUMBERS

This manual applies directly to instruments with serial numbers prefixed 2147A.

With modifications described in Section VII, this manual also applies to instruments with the serial prefixes 1914A through 2145A.

For additional important information about serial numbers, see INSTRUMENTS COVERED BY MANUAL in Section I.

REPORTING ERRORS AND RECOMMENDING IMPROVEMENTS

You can help improve this manual. If you find any mistakes or if you know of a way to improve the procedures, please let us know. Mail your letter, DA Form 2028 (Recommended Changes to Publications and Blank Forms), or DA Form 2028-2 located in the back of this manual direct to Commander, US Army Communications-Electronics Command and Fort Monmouth, ATTN: AMSEL-ME-MP, Fort Monmouth, NJ 07703-5007.

In either case, a reply will be furnished direct to you.

TABLE OF CONTENTS

Section		Page
0	INTRODUCTION	
0-1	Scope.....	0-1
0-2	Consolidated Index of Army Publications and Blank Forms	0-1
0-3	Maintenance Forms, Records, and Reports	0-1
0-4	Reporting Equipment Improvement Recommendations (EIR).....	0-1
0-5	Administrative Storage	0-1
0-6	Destruction of Army Electronics Materiel	0-1

CONTENTS

Section	Page	Section	Page		
I	GENERAL INFORMATION.....	1-1	IV	PERFORMANCE TESTS.....	4-1
	1-1. Introduction.....	1-1	4-1.	Introduction.....	4-1
	1-3. Description.....	1-1	4-3.	Instruments Tested.....	4-1
	1-6. Manual Organization.....	1-1	4-5.	Equipment Required.....	4-1
	1-10. Specifications.....	1-2	4-7.	Test Record.....	4-1
	1-12. Safety Considerations.....	1-2	4-9.	Calibration Cycle.....	4-1
	1-14. Instruments Covered by Manual.....	1-2	4-11.	Frequency Span Accuracy.....	4-2
	1-15. Serial Numbers.....	1-2	4-12.	Tuning Accuracy.....	4-7
	1-17. Manual Changes Supplement.....	1-2	4-13.	Residual FM.....	4-10
	1-20. Manual Backdating Changes.....	1-2	4-14.	Noise Sidebands.....	4-13
	1-23. Options.....	1-9	4-15.	Resolution Bandwidth	
	1-24. Option 001.....	1-9		Accuracy.....	4-15
	1-26. Option 002.....	1-9	4-16.	Resolution Bandwidth	
	1-28. Option 910.....	1-9		Selectivity.....	4-20
	1-30. Accessories Supplied.....	1-9	4-17.	Average Noise Level.....	4-25
	1-32. Termination.....	1-9	4-18.	Spurious Responses.....	4-27
	1-34. Cable Adapter.....	1-9	4-19.	Residual Responses.....	4-34
	1-36. Side Stop Kit.....	1-9	4-20.	Frequency Response.....	4-37
	1-38. Graticule Overlays.....	1-9	4-21.	Bandwidth Switching	
	1-39. Equipment Required But			(Amplitude Variation).....	4-41
	Not Supplied.....	1-10	4-22.	Input Attenuator Accuracy.....	4-43
	1-40. Display Mainframe.....	1-10	4-23.	Reference Level Accuracy.....	4-46
	1-43. Extender Cable Assembly.....	1-10	4-24.	Display Fidelity.....	4-51
	1-45. Measurement Accessories.....	1-10	4-25.	Calibrator Accuracy.....	4-55
	1-46. AC Probe.....	1-10	V	ADJUSTMENTS.....	5-1
	1-48. Modification Kit.....		5-1.	Introduction.....	5-1
	(Option 807 Connections).....	1-10	5-4.	Equipment Required.....	5-1
	1-50. Oscilloscope Camera.....	1-10	5-7.	Adjustment Tools.....	5-1
	1-52. Service Accessories.....	1-10	5-9.	Extender Cable Installation.....	5-1
	1-54. Recommended Test Equipment.....	1-11	5-13.	Related Adjustments.....	5-1
II	INSTALLATION.....	2-1	5-15.	Factory-Selected Components.....	5-2
	2-1. Introduction.....	2-1	5-17.	Second Converter LO and	
	2-3. Initial Inspection.....	2-1		Bandpass Adjustments.....	5-12
	2-5. Preparation for Use.....	2-1	5-18.	Third Converter LO and	
	2-6. Installation.....	2-1		CAL OUTPUT Adjustment.....	5-15
	2-9. Side Stop Kit.....	2-1	5-19.	Slope Adjustment.....	5-18
	2-13. Graticule Overlays.....	2-2	5-20.	Second IF Bandpass Amplifier and	
	2-15. Mainframe Interconnections.....	2-2		Bandpass Filter Adjustment.....	5-21
	2-17. Operating Environment.....	2-2	5-21.	Crystal and LC Bandwidth	
	2-21. Modifications.....	2-2		Filter Adjustments.....	5-23
	2-23. Storage and Shipment.....	2-3	5-22.	3-dB Bandwidth Adjustment.....	5-29
	2-24. Environment.....	2-3	5-23.	Step Gain Assembly RF	
	2-26. Packaging.....	2-3		Gain Adjustment.....	5-33
III	OPERATION.....	3-1	5-24.	Step Amplifier Gain	
	3-1. Introduction.....	3-1		Adjustments.....	5-35
	3-3. Controls, Indicators, and Connectors.....	3-1	5-25.	+19.5V Adjustment.....	5-39
	3-5. Control Grouping.....	3-1	5-26.	Log Amplifier Log and	
	3-13. Variable Persistence and			Linear Adjustment.....	5-40
	Storage Functions.....	3-2	5-27.	Sweep Time Per Division	
	3-15. Persistence and Intensity.....	3-2		Adjustment.....	5-45
	3-19. Photographic Techniques.....	3-2	5-28.	Frequency Control and	
	Operating Precautions.....	3-2		DPM Adjustments.....	5-48
			5-29.	1-dB Offset Adjustment.....	5-51

CONTENTS

Section	Page	Section	Page
VI	REPLACEABLE PARTS	8-5.	Schematic Symbols, Terminology, and Voltage Levels.....
6-1.	Introduction	8-7.	Test Equipment
6-3.	Replaceable Parts List	8-9.	Troubleshooting.....
6-6.	Ordering Information	8-10.	General
VII	MANUAL BACKDATING CHANGES	8-13.	Troubleshooting Hints.....
7-1.	Introduction	8-18.	General Principles of Operation.....
7-5.	Manual Change		Front Switch Assembly A2, Disassembly and Repair.....
	Instructions		8-107
VII	SERVICE		NOTE
8-1.	Introduction		Schematic, block and component location
8-3.	Service Information Index		diagrams are listed under ILLUSTRATIONS.

LIST OF ILLUSTRATIONS

Figure	Page	Figure	Page
1-1.	HP Model 8558B Spectrum Analyzer with Accessories Supplied.....	5-2.	Special Adapter Used in Second Converter LO and Bandpass Test Setup.....
1-2.	Typical Serial Number Label.....	5-3.	Third Converter LO and CAL OUTPUT Adjustment Test Setup.....
1-3.	Service Accessories	5-4.	Slope Adjustment Test Setup.....
2-1.	Location of Side Stops.....	5-5.	Second IF Bandpass Amplifier and Bandpass Filter Adjustment Test Setup.....
3-1.	HP 8558B Installed in HP 182T Display Mainframe	5-6.	Crystal and LC Bandwidth Filter Adjustment Test Setup.....
3-2.	Rear Panel Controls and Connectors	5-7.	Crystal Short Configuration.....
4-1.	Frequency Span Accuracy Test Setup	5-8.	Adjusting Crystal Symmetry and Crystal Centering
4-2.	Frequency Span Accuracy Measurement for Ninth Spectral Line.....	5-9.	3- dB Bandwidth Adjustment Test Setup
4-3.	Frequency Span Accuracy Measurement for Seventeenth Spectral Line	5-10.	Step Gain Assembly RF Gain Adjustment Test Setup.....
4-4.	Tuning Accuracy Test Setup	5-11.	Step Amplifier Gain Adjustment Test Setup
4-5.	Residual FM Test Setup	5-12.	+19.5V Adjustment Test Setup
4-6.	Example of Residual FM	5-13.	Log Amplifier and Linear Adjustment Test Setup
4-7.	Noise Sideband Test Setup	5-14.	Sweep Time Per Division Adjustment Test Setup
4-8.	Resolution Bandwidth Accuracy Test Setup, 3 MHz to 100 kHz	5-15.	Frequency Control and DPM Adjustments Test Setup
4-9.	Resolution Bandwidth Accuracy Test Setup, 1 kHz to 30 kHz	5-16.	I-dB Offset Adjustment Test Setup.....
4-10.	Resolution Bandwidth Selectivity Test Setup, 1 kHz to 30 kHz	6-1.	Cable Assembly W1 (08558-60038 or 08558-60031) Replaceable Parts
4-11.	Resolution Bandwidth Selectivity Test Setup, 100 kHz to 3 MHz	6-2.	Mechanical Chassis Parts.....
4-12.	Average Noise Level Measurement	6-3.	Front Switch Assembly
4-13.	Harmonic Distortion Test Setup	7-1.	Mechanical Chassis Parts (CHANGE A)
4-14.	Intermodulation Distortion Test Setup	7-2.	Front Panel Assembly (CHANGE A)
4-15.	Intermodulation Distortion Products	7-3.	Front Switch Assembly A2, Schematic (CHANGE A)
4-16.	Residual Responses Test Setup	7-4.	Log Amplifier Log and Linear Adjustment Test Setup (CHANGE B).....
4-17.	Frequency Response Test Setup	7-5.	A14 Log Amplifier, Component and Test Point Locations (CHANGE B).....
4-18.	Input Attenuator Accuracy Test Setup.....		
4-19.	Reference Level Accuracy Test Setup		
4-20.	Amplitude Log Display Accuracy Test Setup... ..		
4-21.	Calibrator Accuracy Test Setup		
5-1.	Second Converter LO and Bandpass Adjustment Test Setup.....		

LIST OF ILLUSTRATIONS

Figure	Page	Figure	Page		
7-6.	A14 Log Amplifier Assembly Schematic (CHANGE B).....	7-25	8-21.	Simplified Schematic of Sweep Generator in AUTO Mode.....	8-46
7-7.	A9 Third Converter and A10 Second IF, Component Locations (CHANGE C).....	7-27	8-22.	A8 Sweep Generator Assembly, Component and Test Point Locations....	8-52
7-8.	P/O A9 Third Converter and A10 Second IF, Schematic Diagram (CHANGE C).....	7-28	8-23.	A8 Sweep Generator, Schematic.....	8-53
7-9.	A9 Third Converter and A10 Second IF, Component Locations (CHANGE F).....	7-29	8-24.	Bandpass Amplifier Tank Circuit, Simplified Schematic.....	8-59
7-10.	P/O A9 Third Converter and A10 Second IF, Schematic Diagram (CHANGE F).....	7-30	8-25.	A9 Third Converter Assembly, and A10 Second IF Assembly, Component Locations.....	8-60
8-1.	Symbols Used in Schematics and Block Diagrams.....	8-5	8-26.	A9 Third Converter and A10 Second IF, Schematic.....	8-61
8-2.	Conditions for Schematic Diagram Measurements.....	8-9	8-27.	Crystal Pole, Simplified Schematic.....	8-65
8-3.	CRT Displays for Residual FM Troubleshooting.....	8-13	8-28.	LC Pole, Simplified Schematic.....	8-66
8-4.	Baseline Step Caused by Failure of A7Q18....	8-13	8-29.	A11 Bandwidth Filter No. 1 Assembly, Component and Test Point Locations....	8-68
8-5.	Simplified Block Diagram.....	8-15	8-30.	A11 Bandwidth Filter No. 1, Schematic....	8-69
8-6.	Troubleshooting Block Diagram.....	8-17	8-31.	Equivalent Circuit for Step Gain Amplifiers.....	8-72
8-7.	A1A2U1 Clock.....	8-20	8-32.	A12 Step Gain Assembly, Component and Test Point Locations.....	8-74
8-8.	Integrator and EOC Waveforms for FREQUENCY MHz Display of 1296 MHz.....	8-20	8-33.	A12 Step Gain, Schematic.....	8-75
8-9.	A1A2U1 Outputs for FREQUENCY MHz Display of 1296 MHz.....	8-21	8-34.	A13 Bandwidth Filter No. 2 Assembly, Component and Test Point Locations....	8-78
8-10.	A1A2 DPM Driver Component Locations.....	8-22	8-35.	A13 Bandwidth Filter No. 2, Schematic....	8-79
8-11.	A1A2 DPM Driver (and DPM Display), Schematic.....	8-23	8-36.	Simplified Log Amplifier Stage.....	8-81
8-12.	Front Switch Board Assembly A2A1, Component Locations.....	8-26	8-37.	A14 Log Amplifier Assembly, Component Locations.....	8-84
8-13.	A2 Front Switch, Schematic Diagram.....	8-27	8-38.	A14 Log Amplifier Assembly, Schematic... ..	8-85
8-14.	A3 Input Attenuator.....	8-31	8-39.	Simplified Vertical Driver Circuit.....	8-91
8-15.	A6 YIG Oscillator.....	8-31	8-40.	Simplified Blanking Circuit.....	8-92
8-16.	A4 First Converter, Component Locations.....	8-32	8-41.	A15 Vertical Driver and Blanking Assembly, Component and Test Point Locations....	8-94
8-17.	A5 Second Converter Assembly, Component Locations.....	8-33	8-42.	A15 Vertical Driver and Blanking, Schematic.....	8-95
8-18.	A3 Input Attenuator, A4 First Converter, A5 Second Converter, and A6 YIG Oscillator, Schematic.....	8-35	8-43.	A16 Motherboard Assembly, Components and Test Point Locations.....	8-97
8-19.	A7 Frequency Control Assembly, Component and Test Point Locations.....	8-42	8-44.	A16 Motherboard, Schematic Diagram.....	8-97
8-20.	A7 Frequency Control, Schematic.....	8-43	8-45.	A17 Inverter Assembly, Component Locations.....	8-102
			8-46.	A17 Inverter, Schematic.....	8-103
			8-47.	Locations of Major Assemblies.....	8-105

LIST OF TABLES

Table	Page	Table	Page		
1-1.	HP Model 8558B Specifications.....	1-3	1-4.	Recommended Test Equipment.....	1-14
1-2.	Model 8558B/180-Series Supplemental Characteristics.....	1-6	2-1.	Side Stop Kit (08558-60131).....	2-1
1-3.	Parts Included in Modification Kit 00180-69503.....	1-10	2-2.	HP Model 8558B Mainframe Interconnections.....	2-4
			4-1.	Performance Tests.....	4-1

LIST OF TABLES

Table	Page	Table	Page		
4-2.	Narrow Span Width Error Measurement	4-7	5-4.	Related Adjustments.....	5-11
4-3.	Tuning Accuracy Measurement.....	4-11	5-5.	REF LEVEL FINE Control Check.....	5-41
4-4.	Resolution Bandwidth Selectivity	4-29	5-6.	REFERENCE LEVEL Control Check	5-42
4-5.	Frequency Response, 5 MHz to 1500 MHz. ...	4-48	5-7.	Log Fidelity Check.....	5-47
4-6.	Frequency Response, 100 kHz to 5 MHz	4-48	5-8.	Linear Gain Adjustments.....	5-48
4-7.	Amplitude Accuracy, Switching Between		5-9.	Log Gain Adjustment Limits.....	5-48
	Bandwidths	4-50	5-10.	Log Amplifier Output Limits	5-49
4-8.	Input Attenuator Accuracy.....	4-52	6-1.	Reference Designations and Abbreviations..	6-2
4-9.	IF Gain Accuracy in LOG Mode	4-57	6-2.	Manufacturers Code List.....	6-4
4-10.	IF Gain Accuracy in Linear Mode.....	4-58	6-3.	Replaceable Parts	6-5
4-11.	Conversion Table, Deviation in.....		7-1.	Manual Change Requirement by	
	Linear Mode.....	4-58		Serial Number.....	7-1
4-12.	Vernier Accuracy	4-59	7-2.	Replaceable Parts (CHANGE A).....	7-6
4-13.	Amplitude Log Display Accuracy.....	4-63	7-3.	Replaceable Parts (CHANGE A).....	7-7
4-14.	Sample Computations of Amplitude.....		7-4.	Linear Gain Adjustment Limits.....	7-17
	Log Display Accuracy.....	4-63	7-5.	Log Fidelity Check.....	7-18
4-15.	Performance Test Record.....	4-69	7-6.	Log Gain Adjustment Limits.....	7-19
5-1.	Adjustable Components.....	5-3	7-7.	Replaceable Parts (CHANGE B).....	7-20
5-2.	Factory Selected Components in		8-1.	Service Information	8-2
	Alpha-Numeric Order	5-7	8-2.	Residual FM Troubleshooting	
5-3.	HP Part Numbers of Standard Value			Procedure	8-11
	Replacement Components.....	5-8	8-3.	Truth Table for A2DSI Display	8-20

APPENDICES

APPENDIX

A.	REFERENCES	A-1
B.	COMPONENTS OF END ITEM LIST	B-1
C.	ADDITIONAL AUTHORIZATION LIST(Not Applicable)	
D.	MAINTENANCE ALLOCATION.....	D-1
E.	EXPENDABLE SUPPLIES AND MATERIAL LIST(Not Applicable)	

SECTION 0.**INTRODUCTION****0-1. SCOPE**

This manual describes Spectrum Analyzer, Hewlett-Packard Model 8558B and provides instructions for operation and maintenance.

0-2. CONSOLIDATED INDEX OF ARMY PUBLICATIONS AND BLANK FORMS

Refer to the latest issue of DA Pam 310-1 to determine whether there are new editions, changes or additional publications pertaining to the equipment.

0-3. MAINTENANCE FORMS, RECORDS, AND REPORTS

a. Reports of Maintenance and Unsatisfactory Equipment. Department of the Army forms and procedures used for equipment maintenance will be those prescribed by DA Pam 738-750, as contained in Maintenance Management Update.

b. Report of Packaging and Handling Deficiencies. Fill out and forward SF 364 (Report of Discrepancy (ROD)) as prescribed in AR 735-11-2/DLAR 4140.55/ NAVMATINST 4355.73A/AFR 400-54/MCO 4430.3F.

c. Discrepancy in Shipment Report (DISREP)(SF 361). Fill out and forward Discrepancy in Shipment Report (DISREP)(SF 361) as prescribed in AR 55-38/ NAVSUPINST 4610.33C/AFR 75-18/MCO P4610.19D/DLAR 4500.15.

0-4. REPORTING EQUIPMENT IMPROVEMENT RECOMMENDATIONS (EIR)

If your equipment needs improvement, let us know. Send us an EIR. You, the user, are the only one who can tell us what you don't like about your equipment. Let us know why you don't like the design. Put it on an SF 368 (Quality Deficiency Report). Mail it to Commander, US Army Communications-Electronics Command and Fort Monmouth, ATTN: AMSEL-ME-MP, Fort Monmouth, NJ 07703-5007. We'll send you a reply.

0-5. ADMINISTRATIVE STORAGE

Administrative storage of equipment issued to and used by Army activities will have preventive maintenance performed in accordance with the PMCS charts before storing. When removing the equipment from administrative storage the PMCS should be performed to assure operational readiness. Disassembly and repacking of equipment for shipment or limited storage is covered in paragraph 2-23.

0-6. DESTRUCTION OF ARMY ELECTRONICS MATERIEL

Destruction of Army electronics materiel to prevent enemy use shall be in accordance with TM 750-244-2.

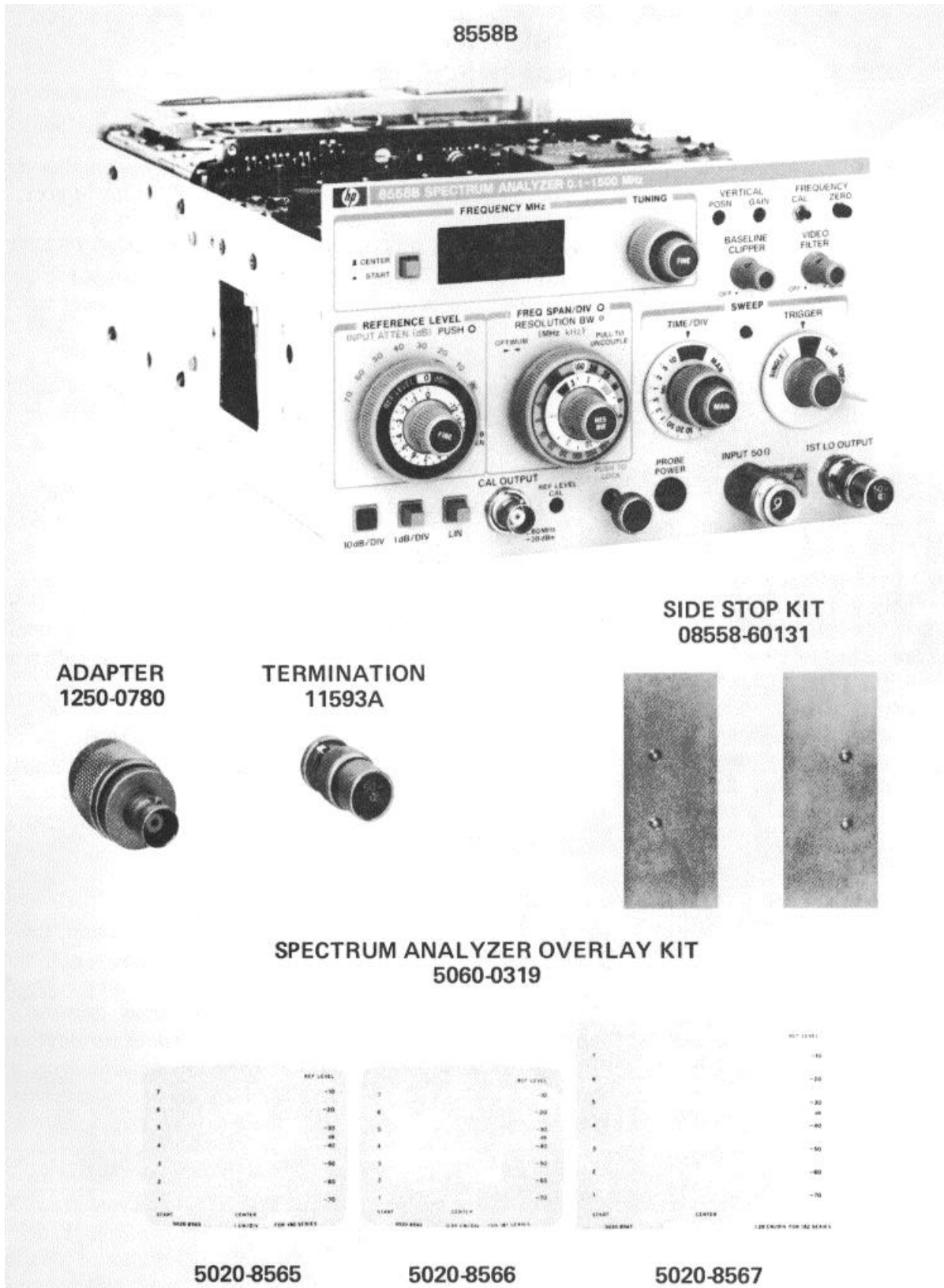

Figure 1-1. HP Model 8558B Spectrum Analyzer with Accessories Supplied

Model 8558B

SECTION I.

GENERAL INFORMATION

1-1. INTRODUCTION

1-2. This Operation and Service manual contains information required to install, operate, test, adjust, and service the Hewlett-Packard Model 8558B Spectrum Analyzer. Figure 1-1 shows the standard instrument and accessories supplied. This section covers instrument identification, description, options, accessories, specifications, and other basic information.

1-3. DESCRIPTION

1-4. The HP 8558B displays the amplitude and frequency of each component of an input signal on a CRT. This display gives quantitative information often not available from a conventional oscilloscope. The HP 8558B is capable of measuring signals from -117 dBm to +30 dBm over a frequency range of 100 kHz to 1500 MHz.

001: 110 dBm to + 30 dBm

002: 63 dBmV to + 80 dBmV

1-5. The complete measuring system includes the HP 8558B Spectrum Analyzer plugged into a compatible Hewlett-Packard display mainframe.

1-6. MANUAL ORGANIZATION

1-7. This manual is divided into eight sections as follows:

SECTION I, GENERAL INFORMATION, contains the instrument description and specifications, explains accessories and options, and lists recommended test equipment.

SECTION II, INSTALLATION AND OPERATION VERIFICATION, contains information concerning initial mechanical inspection, preparation for use, operating environment, packaging and shipping, and operation verification.

SECTION III, OPERATION, contains detailed instructions for operation of the instrument.

SECTION IV, PERFORMANCE TESTS, contains the necessary tests to verify that the electrical operation of the instrument is in accordance with published specifications.

SECTION V, ADJUSTMENTS, contains the necessary adjustment procedures to properly adjust the instrument after repair.

SECTION VI, REPLACEABLE PARTS, contains the information necessary to order parts and/or assemblies for the instrument.

SECTION VII, MANUAL BACKDATING CHANGES, contains backdating information to make this manual compatible with earlier equipment configurations.

SECTION VIII, SERVICE, contains schematic diagrams, block diagrams, component location illustrations, circuit descriptions, and troubleshooting information to aid in repair of the instrument.

1-8. On the title page of this manual, below the manual part number, is a microfiche part number. This number may be used to order 4-by 6-inch microfilm transparencies of the manual. Each microfiche contains up to 60 photo-duplicates of the manual pages. The microfiche package also includes the latest Manual Changes supplement.

1-9. Where text changes are required to reflect Options 001 and 002, these changes are shown in bold type immediately following applicable text. Notes are also included in tables and illustrations where users of Options 001 and 002 need to be informed of differences from the standard instrument. Users of the standard instrument should ignore references to Options 001 and 002.

1-10. SPECIFICATIONS

1-11. Instrument specifications are listed in Table 1-1. These specifications are the performance standards or limits against which the instrument is tested. Table 1-2 lists supplemental characteristics. Supplemental characteristics are not specifications but are typical characteristics included as additional information for the user.

NOTE

To ensure that the HP Model 8558B meets the specifications listed in Table 1-1, performance tests (Section IV) should be performed every six months.

1-12. SAFETY CONSIDERATIONS

1-13. Before operating this instrument, you should familiarize yourself with the safety markings on the instrument and safety instructions in this manual. This instrument has been manufactured and tested according to international safety standards. However, to ensure safe operation of the instrument and personal safety of the user and service personnel, the cautions and warnings in this manual must be followed. Refer to the Safety Considerations at the front of the manual. Refer also to individual sections of this manual for detailed safety notation concerning the use of the instrument as described in those individual sections.

1-14. INSTRUMENTS COVERED BY MANUAL

1-15. Serial Numbers

1-16. Attached to the rear of your instrument is a mylar serial number label. The serial number is in two parts. The first four digits and letter are the serial number prefix; the last five digits are the suffix (see Figure 1-2). The prefix is the same for all identical instruments; it changes only when a change is made to the instrument. The suffix, however, is assigned sequentially and is different for each instrument. The contents of this manual apply to instruments with the serial number prefix(es) listed under SERIAL NUMBERS on the title page.

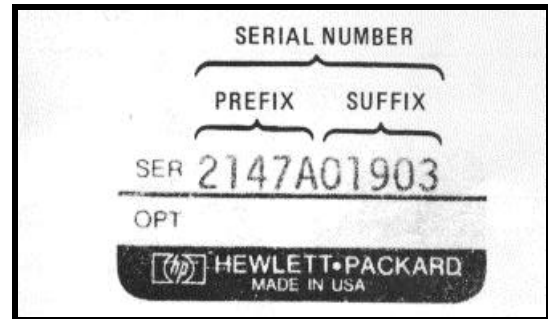

Figure 1-2. Typical Serial Number Label

1-17. Manual Changes Supplement

1-18. An instrument manufactured after the printing of this manual might have a serial number prefix that is not listed on the title page. This unlisted serial number prefix indicates that the instrument is different from those described in this manual. The manual for this newer instrument is accompanied by a yellow Manual Changes supplement. This supplement contains change information that explains how to adapt the manual to the newer instrument.

1-19. In addition to change information, the supplement may contain information for correcting errors in the manual. To keep this manual as current and accurate as possible, Hewlett-Packard recommends that you periodically request the latest Manual Changes supplement. The supplement carries a manual identification block that includes the model number, print date of the manual, and manual part number. Complimentary copies of the supplement are available from Hewlett-Packard. Addresses of Hewlett-Packard offices are located at the back of this manual.

1-20. Manual Backdating Changes

1-21. Instruments manufactured before the printing of this manual have been assigned serial number prefixes other than those for which this manual was written directly. Manual backdating information is provided in Section VII to adapt this manual to earlier serial number prefixes. For instruments with serial number prefixes 1829A and earlier, refer to the HP 8558B Operating and Service Manual dated October 1977, HP part number 08558-90043, and to the Manual Changes supplement supplied with that manual.

Table 1-1. HP Model 8558B Specifications (1 of 3)

FREQUENCY SPECIFICATIONS**FREQUENCY RANGE**

100 kHz to 1500 MHz

FREQUENCY SPANS**Per Division (MHz/Div, kHz/Div)**

14 frequency scale calibrations in 1-2-5 sequence from 5 kHz/div to 100 MHz/div. Start or center frequency is set with the TUNING control and indicated by the FREQUENCY MHz readout.

Zero Span (0)

Analyzer functions as a manually tuned receiver, at the frequency indicated by the FREQUENCY MHz readout, for time-domain display of signal modulation.

FREQUENCY ACCURACY**Tuning Accuracy**

Frequency MHz readout (start or center frequency), after zeroing on the LO feedthrough and operating the FREQUENCY CAL control, +10°C to +40°C: 0-195 MHz: $\pm(1 \text{ MHz} + 20\%$ of frequency span per division)
195-1500 MHz: $\pm(5 \text{ MHz} + 20\%$ of frequency span per division)

Frequency Readout Resolution

0-195 MHz: 100 kHz

195-1500 MHz: 1 MHz

Frequency Span Accuracy $\pm 5\%$ of displayed frequency separation**SPECTRAL RESOLUTION AND STABILITY****Resolution Bandwidths**

Eight selectable resolution (3-dB) bandwidths in 1-3 sequence from 1 kHz to 3 MHz. Bandwidth may be selected independently or coupled with frequency span. Optimum ratio of frequency span to resolution bandwidth is indicated by alignment of markers ($>$ $<$) on the two controls.

Resolution Bandwidth Accuracy:

Individual resolution bandwidth 3-dB points:

 $\pm 20\%$ (+10°C to +40°C)**Selectivity:**60-dB: 3-dB resolution bandwidth ratio: $<15:1$ **Stability****Residual FM:** <1 kHz p-p in 0.1 second**Noise Sidebands:**

>65 dB down, >50 kHz from center of CW signal with 1 kHz resolution bandwidth and full video filtering.

Video Filter

Post-detection low-pass filter averages displayed noise for a smooth trace. The MAX (detent) position selects a video filter bandwidth of approximately 1.5 Hz for noise level measurement.

AMPLITUDE SPECIFICATIONS**AMPLITUDE RANGE**

-117 dBm to +30 dBm

001: -110 dBm to +30 dBm

002: -63 dBm V to +80 dBm V

Maximum Input (Damage) Levels**Total Power:**

+30 dBm (1W, 7.1 Vrms)

001: +30 dBm (1W, 8.7 Vrms)

002: +80 dBm V (1.3W, 10 Vrms)

dc or ac (<100 Hz): ± 50 V**Peak Pulse Power:**

+50 dBm (100W, <10 μ sec pulse width, 0.01% duty cycle) with input attenuation >20 dB

002: +100 dBm V (130W)

Average Noise Level

The displayed average noise level determines sensitivity (minimum discernible signal). Signals at this input level peak approximately 3 dB above the displayed noise.

Maximum average noise level with 10 kHz resolution bandwidth, 0 dB input attenuation, and maximum (MAX) video filtering:

 <-107 dBm (1-1500 MHz)001: <-100 dBm (1-1500 MHz)002: <-53 dBm V (1-1500 MHz)**Calibrated Display Range****Log (from Reference Level):**

70 dB with 10 dB/DIV Amplitude Scale

8 dB with 1 dB/DIV Amplitude Scale

Linear:

8 divisions with LIN Amplitude Scale

AMPLITUDE ACCURACY

With AUTO sweep time selected, amplitude accuracy is determined by one or more of the following factors, depending on the measurement technique.

Calibrator Output-30 dBm +1 dB (into 50 Ω)280 MHz ± 300 kHz001: -30 dBm + 1 dB (into 75 Ω)002: +20 dBm V + 1 dB (into 75 Ω)

Table 1-1. HP Model 8558B Specifications (2 of 3)

Reference Level

10-dB steps and a 12-dB vernier for calibrated Reference Level adjustment from -112 dBm to +60 dBm.

(002: -62 dBm V to + 1 10 dBm V) ¹

Step Accuracy:

Steps referenced with 0 dB input attenuation.

-10 dBm to -80 dBm: ± 0.5 dB

-10 dBm to -100 dBm: ± 1.0 dB

Vernier Accuracy

± 0.5 dB

Frequency Response

Frequency response includes input attenuator, limiter, and mixer flatness:

6 ± 1.0 dB with 10 dB input attenuation

Input Attenuator

0 dB to 70 dB of input attenuation selectable in 10-dB steps

Step Accuracy:

0 dB to 70 dB: $< \pm 0.5$ dB per 10-dB step

Maximum Cumulative Error:

0 dB to 70 dB: $< \pm 1.0$ dB

Bandwidth Switching (Amplitude Variation)

Bandwidths 3 MHz to 300 kHz: $< \pm 0.5$ dB

Bandwidths 3 MHz to 1 kHz: $< \pm 1.0$ dB²

Display Fidelity

CRT linearity and log or linear fidelity affect amplitude accuracy at levels other than Reference Level.

Log Incremental Accuracy:

± 0.1 dB per dB from Reference Level

Log Maximum Cumulative Error:

$< \pm 1.5$ dB over entire 70-dB range

Linear Accuracy:

$\pm 3\%$ of Reference Level

SPURIOUS RESPONSES**Second Harmonic Distortion:**

> 70 dB³ below a -40 dBm input signal with 0 dB input attenuation.

001: -35 dBm input signal

002: + 15 dBm V input signal

Third Order Intermodulation Distortion:

> 70 dB³ below two -30 dBm input signals, separated by > 50 kHz, with 0 dB input attenuation.

001: two -25 dBm input signals

002: two +25 dBm V input signals

Image and Multiple Responses:

> 70 dB³ below a -40 dBm input level with 0dB input attenuation.

001: -35 dBm input level

002: + 15 dBm V input level

RESIDUAL RESPONSES

< -100 dBm (1-1500 MHz) with 0 dB input attenuation and no signal present at input.

001: < -95 dBm (1--1500 MHz)

002: < -50 dBm V (1- 1500 MHz)

SWEEP SPECIFICATIONS**SWEEP TIME****Automatic (AUTO):**

Sweep time adjusted automatically to maintain absolute amplitude calibration for any combination of frequency span, resolution bandwidth, and video filter bandwidth.

Calibrated Sweep Times (sec/Div, mSec/Div):

16 selectable sweep times in 1-2-5 sequence from 0.1 msec/div to 10 sec/div, provided primarily for time-domain calibration in zero span (0).

GENERAL SPECIFICATIONS**TEMPERATURE RANGE**

Operating: 0°C to +55°C

Storage: -40°C to +75°C.

HUMIDITY RANGE

Type-tested from 50% to 95% relative humidity ($< +40$ °C) per requirements of MIL-STD-810C, Method 507.1, Procedure IV.

EMI

Conducted and radiated interference is in compliance with MIL-STD 461A, Methods CE03 and RE02, CISPR Publication 11 (1975) and Mesempfaenger Postverfuegung 526/527/79 (Kennzeichnung Mit F-Nummer/Funkschutzzeichen).

¹ Input level not to exceed +30 dBm (002: +80 dBm V) damage level.

² 100 kHz bandwidth limited to $< 80\%$ relative humidity. Amplitude variation is $< +2.5$ at 95% relative humidity, +40°C.

³ > 60 dB for 100 kHz to 5 MHz input signals. k,

Table 1-1. HP Model 8558B Specifications (3 of 3)

POWER REQUIREMENTS

HP Model 182T/180TR Display with HP Model 8558B Spectrum Analyzer:

48440 Hz, 115 or 230 volts ($\pm 10\%$), 200VA maximum, convection cooled.

HP Model 181T/181TR Display with HP Model 8558B Spectrum Analyzer:

48440 Hz, 115 or 230 volts ($\pm 10\%$), 225 VA maximum, convection cooled.

WEIGHT

HP Model 8558B Spectrum Analyzer:

Net: 5.5 kg (12 lbs)
Shipping: 10.5 kg (23 lbs)

HP Model 182T Display:

Net: 12.5 kg (27 lbs)
Shipping: 16.5 kg (36 lbs)

HP Model 181T Display:

Net: 11.0 kg (24 lbs)
Shipping: 15.5 kg (34 lbs)

HP Model 181TR Display:

Net: 12.0 kg (26 lbs)
Shipping: 17.5 kg (38 lbs)

HP Model 180TR Display:

Net: 12.0 kg (26 lbs)
Shipping: 17.5 kg (38 lbs)

DIMENSIONS

HP Model 8558B Spectrum Analyzer:

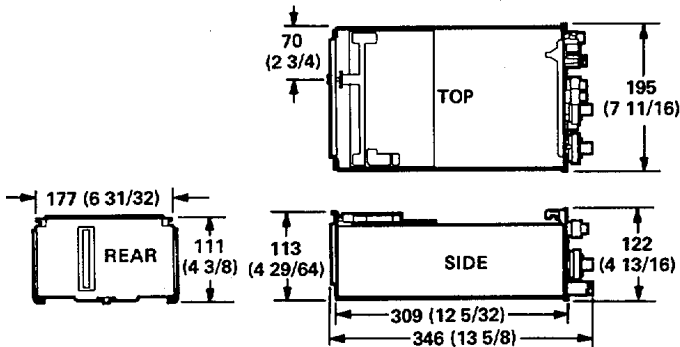

HP Model 182T Display:

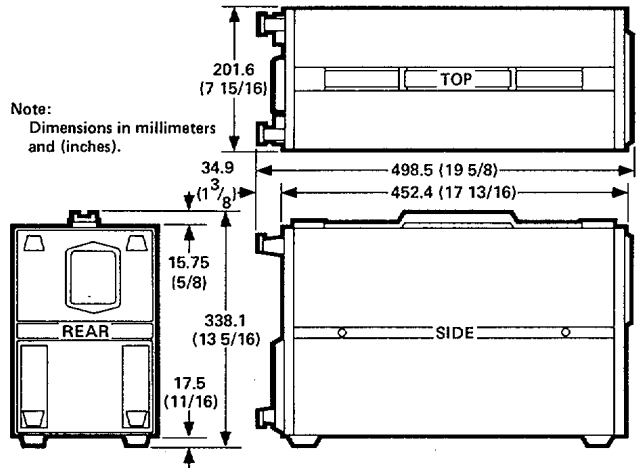

HP Model 181T Display:

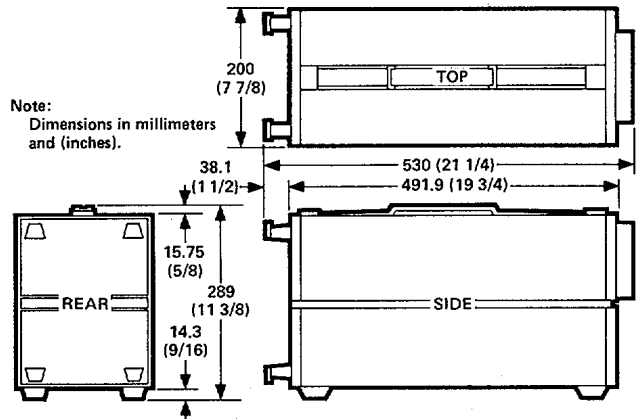

HP Model 180TR/181TR Display:

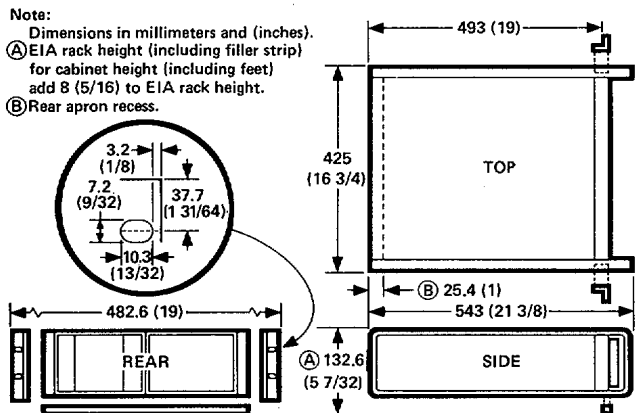

Table 1-2. Model 8558B/180-Series Supplemental Characteristics (1 of 3)

SUPPLEMENTAL CHARACTERISTICS

NOTE:

Values in this table are not specifications. They are typical characteristics included for user information.

FREQUENCY CHARACTERISTICS

FREQUENCY ACCURACY

FREQUENCY ZERO

Adjusts digital FREQUENCY MHz readout. FREQUENCY ZERO control may be used to calibrate the frequency readout on a known signal or on the LO feedthrough.

FREQUENCY CAL

Removes tuning hysteresis from first LO (YIG oscillator). FREQUENCY CAL button should be pressed to maintain FREQUENCY MHz readout accuracy whenever TUNING is changed by more than 50 MHz.

FREQUENCY RANGE

OUT-OF-RANGE BLANKING

The CRT trace is automatically blanked whenever the spectrum analyzer is swept or tuned beyond its frequency range (approximately -50 MHz and 1600 MHz).

SPECTRAL RESOLUTION AND STABILITY

FREQUENCY DRIFT

At fixed start/center frequency, after 2-hour warmup: <50 kHz in 10 minutes.

With temperature changes: <200 kHz/°C

RESOLUTION BANDWIDTH SHAPE

Approximately gaussian (synchronously-tuned, 4-pole filter).

SPECTRAL RESOLUTION

The following graph shows typical spectrum analyzer resolution for different resolution bandwidths.

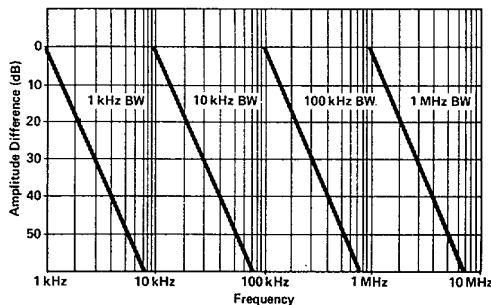

Signal Resolution vs. Frequency Separation

AMPLITUDE CHARACTERISTICS

AMPLITUDE RANGE AND ACCURACY

DYNAMIC RANGE

Maximum power ratio of two signals simultaneously

present at the input that may be measured within the limits of specified accuracy, sensitivity, and distortion (i.e. spurious responses): >70 dB

FREQUENCY RESPONSE AND AVERAGE NOISE LEVEL

The following graphs show typical frequency response and average noise level versus frequency.

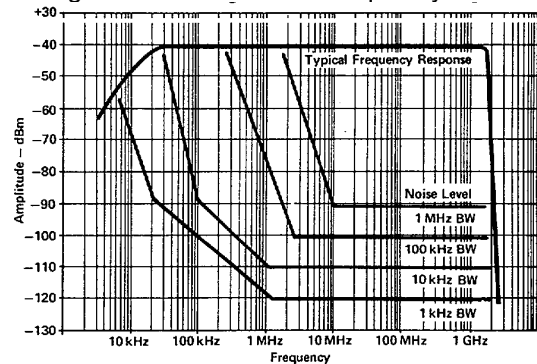

(Standard HP 8558B)

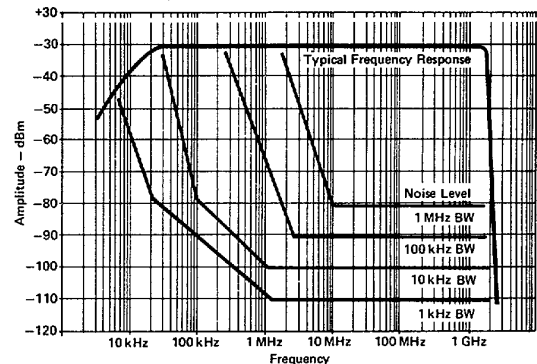

(Option 001)

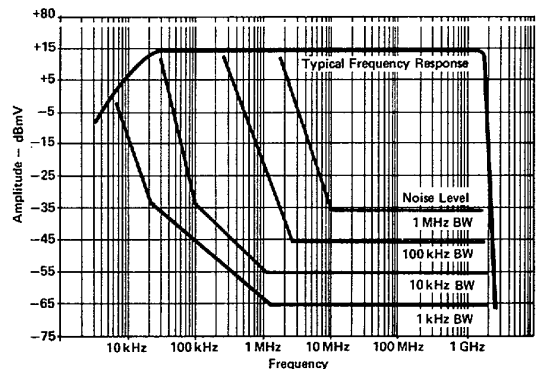

(Option 002)

Average Noise Level and Frequency Response

Table 1-2. Model 8558B/180-Series Supplemental Characteristics (2 of 3)

SUPPLEMENTAL CHARACTERISTICS

NOTE:

Values in this table are not specifications. They are typical characteristics included for user information.

GAIN COMPRESSION

Gain compression is typically less than 1 dB for a -10 dBm input level with 0 dB input attenuation.

001: -5 dBm input level

002: +45 dBmV input level

AMPLITUDE SCALE SWITCHING

Reference Level variation is typically less than ±1 dB for any change in Amplitude Scale.

SPURIOUS RESPONSES

SECOND HARMONIC AND THIRD ORDER INTERMODULATION DISTORTION

The graphs below illustrate typical second harmonic and third order intermodulation distortion.

SWEEP CHARACTERISTICS

SWEEP TIME

CALIBRATED SWEEP TIME ACCURACY (Sec/DIV, mSec/DIV)

Sweep times are typically ±10% of indicated value.

MANUAL

Spectrum analyzer may be swept manually, in either direction, with front panel control.

SWEEP TRIGGER

FREE RUN

End of each sweep triggers new sweep.

LINE

Sweep triggered at ac line frequency.

VIDEO

Sweep triggered on post-detection video waveform. One-half major division of vertical deflection required to trigger sweep.

SINGLE

Single sweep started or reset by turning SWEEP TRIGGER clockwise momentarily.

FRONT PANEL INPUT AND OUTPUT CHARACTERISTICS

SIGNAL INPUT

INPUT IMPEDANCE

50 ohms nominal; Precision Type N female connector.

001 and 002: 75 ohms nominal; 75-ohm BNC female connector.

INPUT SWR

<1.5 SWR with >10 dB input attenuation

001 and 002: <1.5 SWR

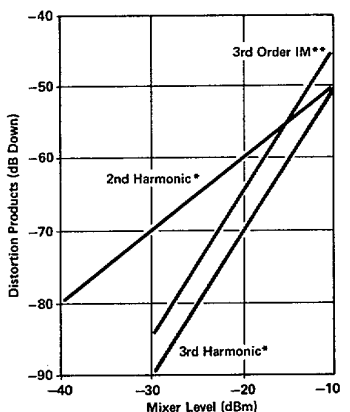

Mixer Level = Input signal level - INPUT ATTEN
 *single input signal > 5 MHz
 **two equal input signals > 5 MHz,
 > 200 kHz separation

(Standard HP 8558B)

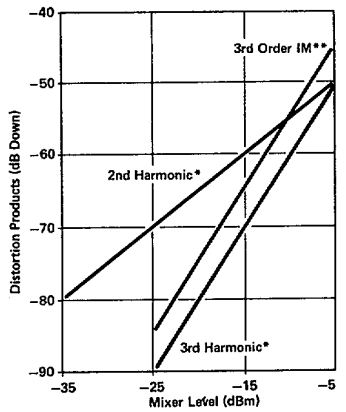

Mixer Level = Input signal level - INPUT ATTEN
 *single input signal > 5 MHz
 **two equal input signals > 5 MHz,
 > 200 kHz separation

(Option 001)

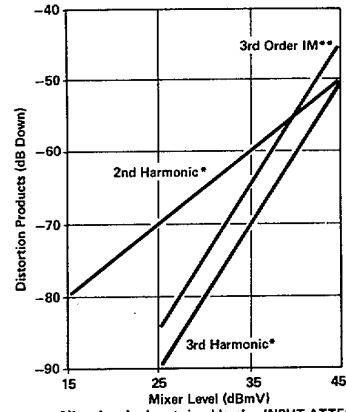

Mixer Level = Input signal level - INPUT ATTEN
 *single input signal > 5 MHz
 **two equal input signals > 5 MHz,
 > 200 kHz separation

(Option 002)

Distortion vs. Mixer Level

Table 1-2. Model 8558B/180-Series Supplemental Characteristics (3 of 3)

SUPPLEMENTAL CHARACTERISTICS**NOTE:**

Values in this table are not specifications. They are typical characteristics included for user information.

CAL OUTPUT

-30 dBm at 280 MHz with second through fourth harmonics greater than -70 dBm (into 50 ohms).

001: -30 dBm at 280 MHz (into 75 ohms)

002: +20 dBm V at 280 MHz (into 75 ohms)

1ST LO OUTPUT

+10 dBm nominal into 50 ohms, 2.05-3.55 GHz.
Terminate with a 50-ohm load when not in use.

PROBE POWER

+15V, -12.6V, and GND (150 mA maximum) for use with HP High-Impedance Probes (i.e. HP 1120A, 1121A, 1123A, 1124A). The HP 1121A is recommended for its low noise characteristics.¹

REAR PANEL OUTPUT CHARACTERISTICS²**VERTICAL, PENLIFT/BLANKING, AND HORIZONTAL OUTPUTS (AUX A, B, D)**

These outputs are compatible with and may be used to drive HP X-Y Recorders (using positive pencoils or TTL penlift input) and CRT monitors.

¹See Section II for details regarding use with 001 and 002 75ohm inputs.

²Rear panel outputs refer to 180T-series display mainframes and other 180-series mainframes with Option 807 installed. Horizontal, vertical, and blanking outputs, attenuated and shifted in dc level, are available on other 180-series mainframes at the MAIN SWEEP, MAIN GATE, and DELAYED GATE outputs, respectively. DO NOT connect an X-Y recorder to the DELAYED GATE OUTPUT, or damage will result.

AUX A VERTICAL OUTPUT

BNC output provides detected video signal from a 50-ohm output impedance. Typical 0-800 mV range corresponds to full 8-division CRT vertical deflection.

AUX B PENLIFT/BLANKING OUTPUT

BNC output provides a +15V penlift/blanking signal from a 10K-ohm output impedance when CRT trace is blanked. Otherwise, output is low at OV (low impedance, 150 mA max.) for an unblanked trace.

AUX C 21.4 MHz IF OUTPUT

BNC output provides 21.4 MHz IF signal (linearly related to spectrum analyzer RF input) from a 50-ohm output impedance. Output bandwidth controlled by spectrum analyzer RESOLUTION BW setting; output amplitude controlled by INPUT ATTEN, REFERENCE LEVEL FINE, and first six REFERENCE LEVEL positions (i.e. -10 through -60 dBm with 0 dB input attenuation). Output level is approximately -10 dBm into 50 ohms with a signal displayed at Reference Level.

002: (i.e. +40 to -10 dBmV with 0 dB input attenuation).

AUX D HORIZONTAL OUTPUT

BNC output provides horizontal sweep voltage from a 5K-ohm output impedance. -5V to +5V range corresponds to full 10-division CRT horizontal deflection.

1-22. This information should not be confused with information contained in the yellow Manual Changes supplement, which is intended to adapt this manual to instrument changes that are accomplished after its printing.

1-23. OPTIONS

CAUTION

The two 75-ohm BNC connectors on Option 001 and Option 002 instruments are not compatible with 50ohm BNC connectors. Direct use of 50-ohm BNC connectors with these instruments might damage the INPUT and CAL OUTPUT connectors.

1-24. Option 001

1-25. Option 001 provides direct-measurement capability in a 75-ohm system. The BNC input and calibration-output connectors have 75 Ω impedance (nominal). Option 001 is calibrated in dBm, providing a measurement range from -110 dBm to +30 dBm. Throughout the manual, differences between the standard instrument and Option 001 are given in boldface type following applicable text references and as necessary in tables and illustrations.

1-26. Option 002

1-27. Option 002 provides direct-measurement capability in a 75-ohm system. The BNC input and calibration-output connectors have 75Q impedance (nominal). Option 002 is calibrated in dBmV, providing a measurement range from -63 dBmV to + 80 dBmV. Throughout the manual, differences between the standard instrument and Option 002 are given in boldface type following applicable text references and as necessary in tables and illustrations.

1-28. Option 910

1-29. One additional Operation and Service manual is provided for each Option 910 ordered. To obtain additional manuals after initial shipment, order by the manual part number, which appears on the title page and on the back cover.

1-30. ACCESSORIES SUPPLIED

1-31. The following accessories, supplied with the instrument, are shown in Figure 1-1:

- BNC termination
- Cable adapter
- Side stop kit
- Graticule overlays

1-32. Termination

1-33. A BNC, 50-ohm termination, HP Model 11593A, is supplied for the front-panel 1ST LO OUTPUT.

1-34. Cable Adapter

1-35. A Type N male to BNC female adapter, HP part number 1250-0780, is supplied with the standard instrument for the use of lightweight cables with BNC connectors.

1-36. Side Stop Kit

1-37. A side stop kit, HP part number 08558-60131, is supplied to prevent the spectrum analyzer from sliding out of the mainframe. When the side stops are installed, the plug-in cannot be removed from the mainframe. Refer to Section II for installation or removal of the side stops.

1-38. Graticule Overlays

Three graticule overlays provide the operator with reference-level labels for the CRT. HP Part Number 5020-8565 is the overlay for 180-series display mainframes. HP Part Number 5020-8566 is the overlay for 181-series display mainframes. HP Part Number 5020-8567 is the overlay for 182-series display mainframes. For proper installation of the graticule overlay, refer to Section II.

1-39. EQUIPMENT REQUIRED BUT NOT SUPPLIED

CAUTION

The 75-ohm BNC input connector on ANT Option 001 and 002 instruments is not compatible with 50-ohm BNC connectors. Direct connection of an AC probe might damage the input connector.

1-40. Display Mainframe

1-41. A 180T-series display mainframe (180TR, 181T, 181TR, or 182T) is recommended for use with the HP Model 8558B. In the 180T-series mainframe, the rear-panel auxiliary output connectors (AUX A, AUX B, AUX C, and AUX D) provide, respectively, Vertical Output, Pen Lift Output, 21.4 MHz IF Output, and Horizontal Output.

001 and 002: The AC probes have a 50-ohm output impedance. Use of a probe with the 75-ohm Option 001 or 002 without proper impedance matching causes a + 1.58 dB error in displayed signal levels.

1-42. A standard 180-series Display mainframe (180A/AR, 180C/D, 181A/AR, 182A/C, or 184A/B) provides only horizontal, vertical, and blanking rear panel outputs. Furthermore, these outputs are attenuated and shifted in dc level. Unbuffered rear panel outputs (similar to the 180T-series) are provided only if Option 807 is installed.

1-48. Modification Kit (Option 807 Connections)

1-49. A modification kit, HP part number 00180-69503, provides the materials and information necessary to install unbuffered rear panel connections (formerly included in Option 807) in the following display mainframes: 180A/AR, 180C/D, 181A/AR, 182A/C, and 184A/B. Refer to Table 1-3 for a description of parts included in the modification kit.

1-43. Extender Cable Assembly

1-44. An Extender Cable Assembly (Figure 1-3), HP Part Number 5060-0303, allows operation of the HP 8558B outside the display mainframe. This provides access to the HP 8558B for necessary adjustments and some performance tests. This cable is also useful for troubleshooting.

1-50. Oscilloscope Camera

1-51. The HP Model 197B, Option 002, General Purpose Camera can be used with 180- and 181-series display mainframes to make a permanent record of measurements. The HP 10367A adapter allows the camera to be used with 182-series mainframes.

1-45. MEASUREMENT ACCESSORIES

1-46. AC Probe

1-47. The HP Model 8558B Spectrum Analyzer has a front-panel PROBE POWER connector for the use of high-impedance active probes such as the HP 1120A, HP 1121A, HP 1123A, and HP 1124A. High-impedance probes permit testing of high-frequency circuits without significant loading effects. The low-noise, AC-coupled HP 1121A is preferred for use with the HP 8558B.

1-52. SERVICE ACCESSORIES

1-53. Service accessories are shown in Figure 1-3.

Table 1-3. Parts Included in Modification Kit 00180-69503

Quantity	Description	HP Part Number
1	Output Amplifier Assembly (Auxiliary Output Board)	00180-66551
1	Label	7120-3116
2	3/4 inch pieces of shrink tubing	0890-0720
1	Service Note	180A/AR-10, 180C/D-2, 181A/AR8 182A/C-1, or 184/B-1 (modification is similar for all instruments listed)

1-54. RECOMMENDED TEST EQUIPMENT

1-55. Equipment required for operation verification, performance tests, adjustments, and

troubleshooting of the HP Model 8558B is listed in Table 1-4. Other equipment may be substituted if it meets or exceeds the critical specifications listed in the table.

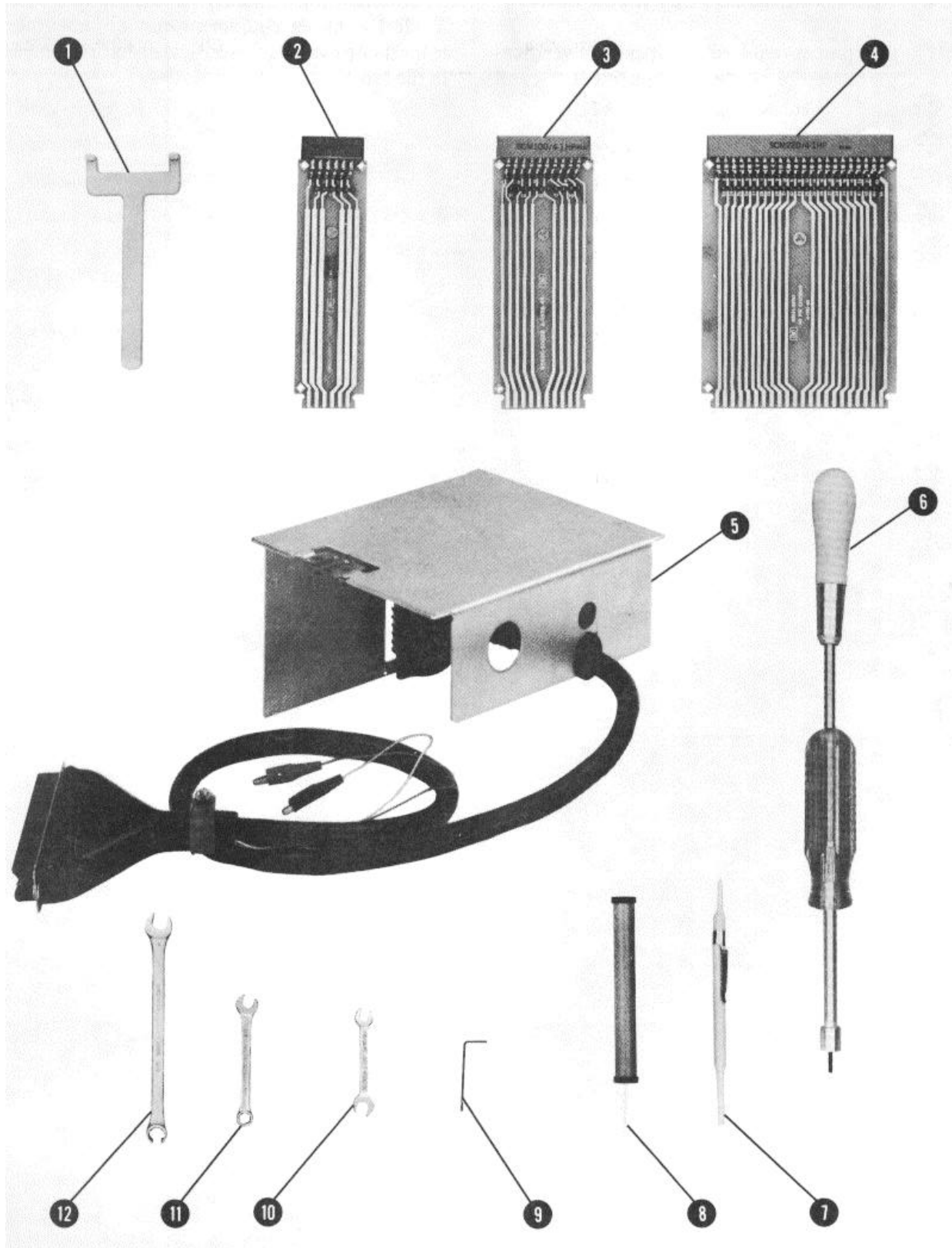

Figure 1-3. Service Accessories (1 of 2)

Item	Description	CD	HP Part Number
(1)	Board Puller, 2 prongs to lift PC boards	1	03950-4001
(2)	Extender Board, 6 pin, 12 contacts	2	08559-60042
(3)	Extender Board, 10 pin, 20 contacts	2	85680-60028
(4)	Extender Board, 22 pin, 44 contacts	8	08565-60107
(5)	Extender Cable Assembly, for plug-in operation out of display mainframe	9	5060-0303
(6)	Tuning Tool, modified 5/16 inch nut driver with modified No. 10 Allen driver	6	08555-60107
(7)	Alignment tool, metal tip in plastic	7	8710-0630
(8)	Alignment tool, non-metallic	4	8710-0033
(9)	Wrench, No. 2 Bristol	0	8710-0055
(10)	Wrench, 15/64 inch, combination	8	8710-0946
(11)	Wrench, 1/4 inch, open end	2	8720-0014
(12)	Wrench, 5/16 inch, slotted box end/open end	9	08555-20097

Figure 1-3. Service Accessories (2 of 2)

Table 1-4. Recommended Test Equipment (1 of 4)

Equipment	Critical Specifications	Recommended Model	Use*
Display Mainframe	HP 180T Series with variable persistence	HP 181T/TR	P, A, T
Oscilloscope	Time Base: 1 ms/cm to 10 ms/cm Vertical Sensitivity: 1 mV/cm to 20 V/cm	HP 1741A	A, T
Frequency Counter	Frequency Range: 150 MHz to 1.5 GHz Sensitivity: -30 dBm	HP 5342A	P, A, T
Timer/Counter	Time base: 10 us	HP 5308A	A, T
Digital Voltmeter	Accuracy: $\pm(0.05\% \text{ Rdg} \pm \text{digit})$	HP 3455A	P, A, T
Power Meter	Power Range: -20 dBm to +10 dBm	HP 435A/B	P, A, T
Power Sensor	Frequency Range: 100 kHz to 1.5 GHz Maximum SWR: 1.1, 0.1 to 1 GHz	HP 8482A	P, A, T
Amplifier	Frequency Range: 200 MHz to 300 MHz Gain: > 20 dB Impedance: 50 Ω	HP 8447D	P, A, T
Signal Generator (2 required)	Frequency Range: 4 MHz to 305 MHz Drift: Less than 50 ppm (or 5 Hz, whichever is greater) Harmonic Distortion: > 30 dB below fundamental Noise Sidebands: > 80 dB down, 50 kHz away, 1 kHz BW	HP 8640B	P, A, T
Tracking Generator	Frequency Range: 5 MHz to 1500 MHz	HP 8444A Opt. 059	P, T
Sweep Oscillator	Manual Sweep	HP 8350A	A
RF Plug-In	Frequency Range: 10 MHz to 1.5 GHz Flatness (external leveling): < ± 0.1 dB	HP 83522A	A
Spectrum Analyzer	Frequency Range: 10 MHz to 1.5 GHz	HP 141T/8552B/ 8555A	T
Comb Generator	Accuracy: 0.01%	HP 8406A	P, A, T
Function Generator	Frequency Range: 5 kHz to 5 MHz	HP 3310A	P, T
Crystal Detector	Frequency Range: 10 MHz to 1.5 GHz Frequency Response: ± 0.2 dB/octave to 2 GHz; ± 0.5 dB overall	HP 423B	A, T
*P = Performance Test; A = Adjustment; T = Troubleshooting			

Table 1-4. Recommended Test Equipment (2 of 4)

Equipment	Critical Specifications	Recommended Model	Use*
300 MHz LPF	Rejection: > 50 dB for signals above 300 MHz	Telonic TPL 3004AB	P, A, T
Power Splitter	Frequency Range: 100 kHz to 1.5 GHz Input SWR: <, 1.15	HP 11667A	P, A
10 dB Attenuator (2 required)	Frequency Range: 100 kHz to 1.5 GHz Accuracy: ± 0.5 dB	HP 8491A Opt. 010	P, A
Step Attenuator	Frequency Range: 20 MHz to 305 MHz Attenuation: 12 dB in 1-dB steps calibrated at 30 MHz by a standards lab Accuracy: ± 0.25 dB	HP 355C Opt. H80	P, A, T
Step Attenuator	Frequency Range: 20 MHz to 305 MHz Attenuation: 80 dB in 10-dB steps calibrated at 30 MHz and 280 MHz by a standards lab Accuracy: ± 0.01 dB $\pm 0.02/10$ dB step at calibrated frequencies	HP 355D Opt. H82	P, A, T
Termination	Impedance: 50 Ω	HP 908A/11593A	P, A
Type N Cable	50 Ω coaxial cable with Type N (m) connectors on both ends	HP 11500A	P, A
BNC Cable, 20 cm (9 in)	50 Ω coaxial cable with BNC (m) connectors on both ends	HP 10502A	P, A, T
BNC Cable, 120 cm (48 in) (2 required)	50 Ω coaxial cable with BNC (m) connectors on both ends	HP 10503A	P, A, T
Cable	BNC to Banana Plug	HP 11001A	P
Cable	SMC (f) to BNC (m)	HP 11592-60001	A, T
Cable	Banana Plug to Alligator Clips	HP 11102A	A
Adapter	Banana plugs to BNC (f)	HP 10111 A	P, T
Adapter	N (m) to BNC (f) (3 required)	HP 1250-0780	P, A
Adapter	SMC (m) to BNC (m)	HP 1250-0831	P
Adapter	BNC (f) to BNC (f)	HP 1250-0080	P
Adapter	BNC Tee	HP 1250-0781	A

*P = Performance Test; A = Adjustment; T = Troubleshooting

Table 1-4. Recommended Test Equipment (3 of 4)

Equipment	Critical Specifications	Recommended Model	Use*
Adapter	N (m) to N (m)	HP 1250-1475	P
Adapter	BNC (m) to BNC (m)	HP 1250-0216	P
Adapter	N (f) to BNC (m)	HP 1250-0077	P
Adapter	SMC (m) to SMC (m)	HP 1250-0827	A, T
Adapter	Type N (m) to SMC (m)	HP 1250-1023	A, T
Adapter	BNC (f) to Alligator Clips	HP 8120-1292	A, T
Adapter	SMC (f) to SMC (f)	HP 1250-1113	A, T
Adapter	Type N (m) to SMA (f)	HP 1250-1250	P, A
Adapter	BNC (f) to SMA (m)	HP 1250-1200	P
Adapter	SMA (f) to SMA (f)	HP 1250-1158	P
Extender Board	6 pin, 12 contacts with 51.1 Ω resistor from pin 1 to pin 5	HP 08505-60109 HP 0757-0394	A, T
NOTE The following equipment is required for Option 001 and Option 002.			
<i>Termination</i>	<i>Impedance: 75 W</i>	<i>HP 11652-60010</i>	<i>P</i>
<i>Power Sensor</i>	<i>Frequency Range: 10 MHz to 2 GHz</i> <i>Maximum SWR: 1.18, 10 MHz to 2 GHz</i>	<i>HP 8483A</i>	<i>T</i>
<i>Adapter</i>	<i>75W BNC (m) to 75W Type N (f)</i>	<i>HP 1250-1534</i>	<i>T</i>
<i>Minimum Loss Adapter</i> <i>5.72 dB attenuation</i>	<i>75W BNC (f) to 50W SMA (m)</i>	<i>HP 08558-60031</i>	<i>P, A, T</i>
<i>Adapter</i>	<i>BNC (f) to SMA (m)</i>	<i>HP 1250-1200</i>	<i>T</i>
<i>Adapter</i>	<i>SMA (f) to SMA (f)</i>	<i>HP 1250-1158</i>	<i>P, T</i>
*P = Performance Test; A = Adjustment; T = Troubleshooting			

Table 1-4. Recommended Test Equipment (4 of 4)

Equipment	Critical Specifications	Recommended Model	Use*
<i>Adapter</i>	<i>N (f) to N (f)</i>	<i>HP 1250-0777</i>	<i>A, T</i>
<i>Cable</i>	<i>BNC, 30 cm (12 in), 75W</i>	<i>HP 11652-60012</i>	<i>P, A, T</i>
<i>Cable</i>	<i>BNC, 60 cm (24 in), 75W</i>	<i>HP 11652-60013</i>	<i>P, A, T</i>
<i>Cable</i>	<i>BNC, 90 cm (37 in), 75W</i>	<i>HP 11652-60014</i>	<i>P, A, T</i>
<i>Adapter</i>	<i>BNC (m) to BNC (m)</i>	<i>HP 1250-1288</i>	<i>P, A, T</i>
<i>Adapter</i>	<i>Type N (m) to SMA (f)</i>	<i>HP 1250-1250</i>	<i>P, A, T</i>
*P = Performance Test; A = Adjustment; T = Troubleshooting			

**SECTION II.
INSTALLATION**

2-1. INTRODUCTION

2-2. This section includes information on initial inspection, preparation for use, and storage and shipping requirements for the HP Model 8558B.

2-3. INITIAL INSPECTION

2-4. Inspect the shipping container for damage. If the shipping container or cushioning material is damaged, it should be kept until the contents of the shipment have been checked for completeness and the instrument has been checked mechanically and electrically. The contents of the shipment should be as shown in Figure 1-1. The electrical performance is checked with the procedures in Section IV. If the contents are incomplete, if there is mechanical damage or defect, or if the instrument does not pass the Performance Test procedures, notify the nearest Hewlett-Packard office. If the shipping container is damaged, or if the cushioning material shows signs of stress, notify the carrier as well as the Hewlett-Packard office. Keep the shipping materials for inspection by the carrier. The Hewlett-Packard office will arrange for repair or replacement without waiting for a claim settlement.

2-5. PREPARATION FOR USE

2-6. Installation

2-7. When properly installed, the spectrum analyzer obtains all necessary power from the display mainframe. The rear panel connector provides the interface.

CAUTION

BEFORE SWITCHING ON THIS INSTRUMENT, make sure it is adapted to the voltage of the ac power source to be used and the proper fuse is installed. Failure to set the ac power input of the instrument

for the correct voltage level could cause damage to the instrument when plugged in. Refer to the display mainframe Operation and Service Manual for line voltage and fuse selection.

2-8. To install the spectrum analyzer in the mainframe:

1. Set display mainframe LINE switch to OFF.
2. Pull out lock knob and slide plug-in toward rear of compartment until it is seated firmly in place.
3. Push in lock knob to secure spectrum analyzer in mainframe.

2-9. Side Stop Kit

2-10. Installation of a Side Stop Kit, HP part number 08558-60131, prevents the removal of the analyzer from the 180-series mainframe without the use of hand tools. This kit contains two side stops, mounting hardware, label, and installation instructions. (Refer to Table 2-1 for part numbers of individual items.)

Table 2-1. Side Stop Kit (08558-60131)

Quantity	Description	HP Part Number	C D
2	SIDE STOP	08558-00094	7
4	MACHINE SCREW, 440 .438-IN-LG 82 DEG FLATHEAD	2200-0168	9
1	LABEL, FRONT-PANEL	7120-8131	7
1	LABEL, INSTRUCTIONS	7120-8215	8

2-11. To install side stops:

WARNING

Before removing covers from the display mainframe, disconnect line power by removing the ac power cord.

1. Remove side covers from bottom section of mainframe. (Remove only right side cover if mainframe is a rack-mounted model.)
2. Use flathead machine screws to install side stops as shown in Figure 2-1.0
3. Reinstall side covers on mainframe.
4. Place caution label on front panel of spectrum analyzer (upper right-hand corner) to indicate that plug-in is secured with side stops.

2-12. To remove side stops:

WARNING

Before removing covers from the display mainframe, disconnect line power by removing the ac power cord.

1. Remove side covers from bottom section of mainframe. (Remove only right side cover if mainframe is a rack-mounted model.)
2. Remove side stops. (See Figure 2-1.)
3. Reinstall side covers on display mainframe.

2-13. Graticule Overlays

2-14. To install a graticule overlay:

1. Select proper overlay. HP part number 5020-8565 is for 180TR display mainframes, HP part number 5020-8566, for 181T/TR display mainframes, and HP part number 5020-8567, for 182T display mainframes.

2. For 180TR and 181T/TR mainframes, remove CRT bezel and metallic-mesh contrast filter. Insert proper overlay and replace contrast filter and CRT bezel.
3. For 182T mainframes, grasp top portion of CRT bezel and pull straight up. Remove metallic-mesh contrast filter and insert proper overlay and contrast filter. (Either the metallic-mesh contrast filter or a light blue contrast filter may be used.)
4. Slide bezel back into place to retain overlay and filter.

2-15. Mainframe Interconnections

2-16. When the HP 8558B is properly installed in the display mainframe, the interconnections are as listed in Table 2-2.

2-17. Operating Environment

2-18. Temperature. The instrument may be operated in temperatures from 0°C to + 55°C.

2-19. Humidity. The instrument may be operated in environments with relative humidity from 5 percent to 95 percent, 0°C to +40°C. The recommended long-term operating environment is 5 percent to 80 percent relative humidity. The instrument should also be protected from abrupt temperature changes that cause internal condensation.

2-20. Altitude. The instrument may be operated in altitudes up to 4572 meters (15,000 feet).

2-21. Modifications

2-22. A Modification Kit, HP part number 00180-69503, provides materials and information necessary to add Option 807 rear-panel connections to the standard HP 180-series display. Refer to Table 1-3 in Section I. Option 807 is factory-installed in 180T, 181T, 181TR, and 182T mainframes. The modification kit is required for use with other mainframes if all four rear-panel outputs are needed.

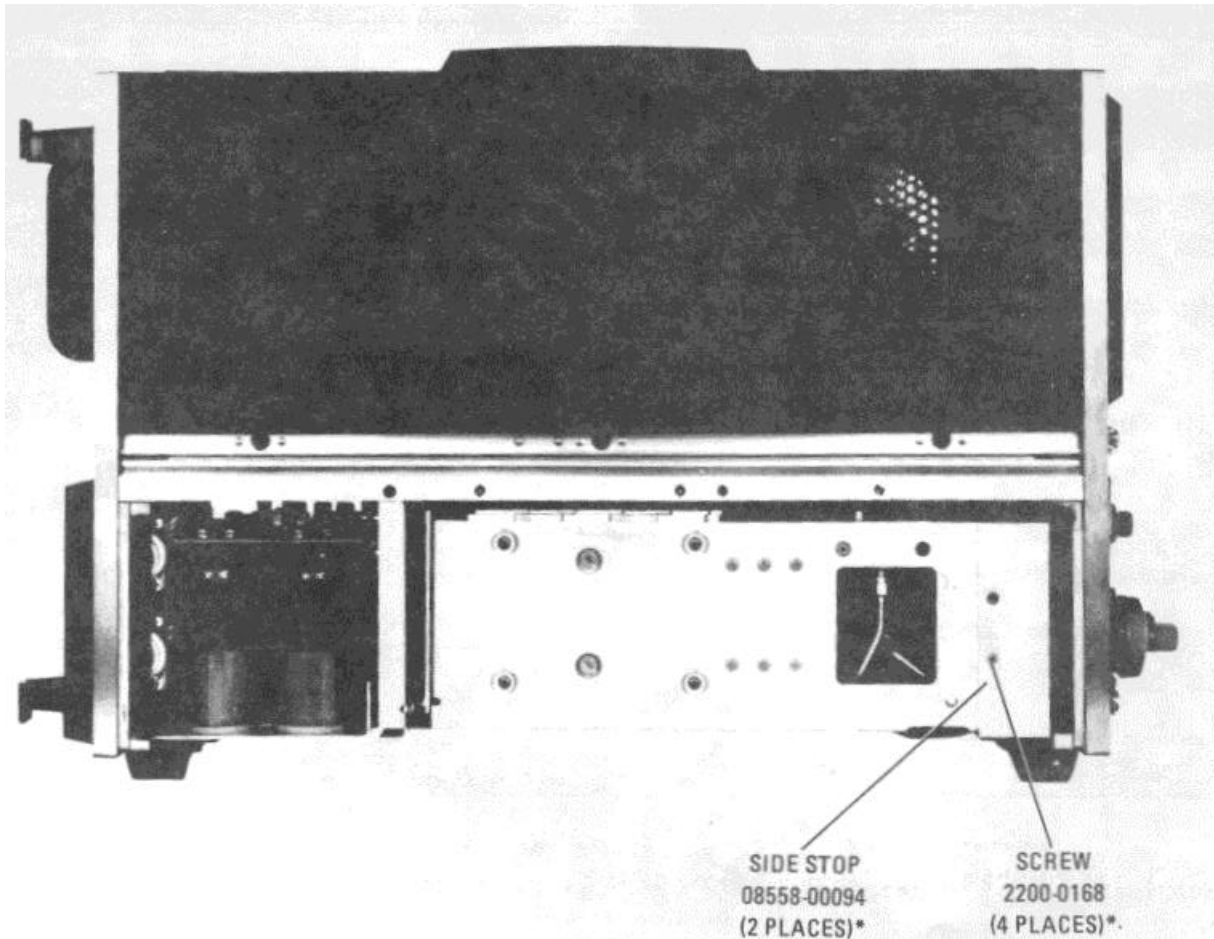

* Only one side stop and two screws are used for rackmount models.

Figure 2-1. Location of Side Stops

2-23. STORAGE AND SHIPMENT

2-24. Environment

2-25. The instrument may be stored or shipped in environments within the following limits:

Temperature: -40°C to +75°C
 Humidity: 5% to 95% (0°C to +40°C)
 Altitude: Up to 15240 meters (50,000 feet)

The instrument should also be protected from temperature extremes which cause condensation within the instrument.

2-26. Packaging

2-27. Original Packaging. Containers and materials identical to those used in factory packaging are available through Hewlett-Packard offices. If the instrument is being returned to Hewlett-Packard for servicing, attach a tag indicating the type of service required, return address, model number, and full serial number. A supply of these tags is provided at the end of this section. Mark the container FRAGILE to assure careful handling. In any correspondence, refer to the instrument by model number and full serial number.

Table 2-2. HP Model 8558B Mainframe Interconnections

Pin on P1	Signal or Voltage	Pin on P1	Signal or Voltage
1	CRT HORIZ (adjusted horizontal signal)	17	BLANKING
2	GROUND from mainframe (jumpered to pin 8)	18	NC
3	NC	19	GROUND from mainframe (jumpered in pin 24)
4	L NORM	20	AUTO SWP
5	YNORM	21	BEAM FINDER
6	NC	22	NC
7	SING SWP	23	NC
8	GROUND from mainframe (jumpered to pin 2)	24	GROUND from mainframe (jumpered to pin 19)
9	MAN SWP	25	NC
10	NC	26	NC
11	AUX D Horizontal Output (to mainframe rear panel)	27	NC
12	AUX C 21.4 MHz IF Output (to mainframe rear panel)	28	-12.6 VDC from mainframe
13	AUX B Penlift/Blanking Output (to mainframe rear panel)	29	+15 VDC from mainframe
14	AUX A Vertical Output (to mainframe rear panel)	30	+100 VDC from mainframe
15	GROUND	31	30V p-p from mainframe (for LINE TRIGGER)
16	NC	32	NC
		W10P3 (2 contacts)	+VERT (top contact, yellow wire) -VERT (bottom contact, orange wire)

2-28. Other Packaging. The following general instructions should be used for repackaging with commercially available materials:

1. Wrap instrument in heavy paper or plastic. If shipment is to a Hewlett-Packard office or service center, attach a tag indicating type of service required, return address, model number, and full serial number. A supply of these tags is provided at end of this section.
2. Use a strong shipping container. A double-wall carton made of 350-pound test material is adequate.

3. Use enough shock-absorbing material (3- to 4-inch layer) around all sides of the instrument to provide firm cushion and prevent movement inside container. Protect control panel with cardboard.
4. Seal shipping container securely.
5. Mark shipping container FRAGILE to assure careful handling.

SECTION III. OPERATION

3-1. INTRODUCTION

3-2. This section provides operating information for the Model 8558B Spectrum Analyzer. It also provides a brief description of display mainframe controls. For a detailed description of the display mainframe, refer to its manual.

3-3. CONTROLS, INDICATORS, AND CONNECTORS

3-4. The spectrum analyzer is used with one of the 180-series display mainframes. The 180T-series display mainframes, or the 180-series mainframes with Option 807, have the correct rear-panel connections for spectrum analyzer horizontal, vertical, penlift, and IF outputs. Figure 3-1 shows the front-panel features of the HP 8558B Spectrum Analyzer and the display mainframe. Figure 3-2 shows the rear-panel features of the HP 8558B. The rear panels of all 180T-series mainframes, and 180-series mainframes with Option 807, are basically the same.

3-5. Control Grouping

3-6. The spectrum analyzer and display mainframe front-panel controls fall into three general groups: those that deal with the display, those that deal with frequency, and those that deal with amplitude.

3-7. Display. The display group consists of:

- SWEEP TIME/DIV
- SWEEP TRIGGER
- VERTICAL POSN
- VERTICAL GAIN
- MAN SWEEP
- HORIZ GAIN (rear panel of 8558B)
- VIDEO FILTER
- BASELINE CLIPPER
- HORIZONTAL POSITION
- INTENSITY
- FOCUS
- TRACE ALIGN
- ASTIG

3-8. The display group enables the operator to calibrate the display and to select a variety of scan and display conditions. The controls are explained in Figures 3-1 and 3-2. However, when the SWEEP TIME/DIV control is placed in the AUTO position, sweep time is controlled by the RESOLUTION BW, FREQ SPAN/DIV, and VIDEO FILTER controls.

3-9. Frequency. The frequency group consists of:

- TUNING
- RESOLUTION BW
- FREQ SPAN/DIV

3-10. The frequency group enables the operator to control how the spectrum analyzer displays the frequency domain. The RESOLUTION BW and FREQ SPAN/DIV controls when pushed in are coupled together, and moving either control moves the other. When the SWEEP TIME/DIV control is in the AUTO position varying the RESOLUTION BW or the FREQ SPAN/DIV (coupled or uncoupled) will change the sweep time to maintain calibration. With the two controls coupled together in the OPTIMUM position, RESOLUTION BW's of 3 MHz to 1 kHz will be automatically selected as the FREQ SPAN/DIV is narrowed from 100 MHz to 0. TUNING controls coarse and fine (coarse is larger knob) set the center frequency of the displayed spectrum. RESOLUTION BW control determines the resolution of the signals on the CRT.

3-11. Amplitude. The amplitude group consists of:

- REFERENCE LEVEL
- INPUT ATTEN
- REF LEVEL FINE
- REF LEVEL CAL
- 10 dB/DIV - 1 dB/DIV - LIN (Amplitude Scale)

3-12. The amplitude group enables the operator to measure signal amplitude in units of either voltage or dBm.

3-13. Variable Persistence and Storage Functions

3-14. With the 181T/TR Display Mainframe, the operator can set trace persistence for a bright, steady trace that does not flicker, even on the slow sweeps required for narrow band analysis. The variable persistence also permits the display of low repetition rate pulses without flickering; and using the longest persistence, intermittent signals can be captured and displayed. The storage capability allows side-by-side comparison of changing signals.

3-15. Persistence and Intensity

CAUTION

Excessive INTENSITY may damage the CRT storage mesh.

3-16. These controls determine the appearance of the CRT trace. Specifically, PERSISTENCE controls the rate at which a signal is erased and INTENSITY controls the trace brightness as the signal is written. With a given PERSISTENCE setting, the actual time of trace visibility can be increased by greater INTENSITY. Since the PERSISTENCE control sets the rate of trace erasure, a brighter trace requires more time to be erased. Conversely, a display of low intensity disappears more rapidly. The same principle applies to a stored display of high or low intensity.

3-17. Storage. These controls select the storage mode in which the CRT functions. In ERASE mode, STORE, WRITE, and MAX WRITE are disconnected and all written signals are removed from the CRT. The STORE selector disconnects the WRITE, MAX WRITE, and ERASE functions and implements signal retention at reduced intensity. In the STORE mode, PERSISTENCE and INTENSITY have no function.

3-18. Writing Speed. In the MAX WRITE mode, the CRT storage surface is primed to allow much faster writing on the storage surface. Since the erasing rate is decreased, the entire screen becomes illuminated more rapidly and the display is obscured. The effective persistence and storage times are thus considerably reduced. For this reason, MAX WRITE is not normally used with a spectrum analyzer plug-in.

3-19. Photographic Techniques

3-20. The HP Model 197A Oscilloscope Camera attaches directly to the spectrum analyzer's CRT bezel without adapters. Flood guns in the CRT provide background lighting of the display. When photography of stored traces (181T/TR) is required, a double exposure is needed. (Flood guns are turned off when STORE is pressed.) See Application Note AN 150-5 for full details.

OPERATING PRECAUTIONS

The spectrum analyzer is a sensitive measuring instrument. To avoid damage to the instrument, do not exceed the following Absolute Maximum Inputs:

Total Power: + 30 dBm (1W, 7.1 Vrms)
Option 001: + 30dBm(1W, 8.7 Vrms)
Option 002: +80dBmV(1.3W, 9.9 Vrms)

dc or ac (< 100 Hz): $\pm 50V$

Peak Pulse Power:
 + 50 dB, (100W, < 10 μs pulse width,
 0.01% duty cycle) with ≥ 20 dB INPUT ATTEN
Option 002: + 100 dBmV (130W), < 10 ns

Overloading the input with too much power, peak voltages, or dc voltages will damage the input circuit and require expensive repairs.

CAUTION

While the analyzer's reference level may be set for power levels up to +60 dBm, the total input power must not exceed the absolute maximum limits listed.

FRONT PANEL ADJUSTMENT PROCEDURE

Whenever an HP 8558B Spectrum Analyzer plug-in is reinstalled in a different mainframe, the spectrum

analyzer should be calibrated to ensure proper correlation between plug-in and display. It is good practice to execute this adjustment procedure periodically (recommended daily) to correct for changes in calibration which may occur over a period of time. These adjustments are also an excellent way for the new user to become acquainted with the spectrum analyzer. For reference, a front panel view appears in Figure 3-1.

If an HP 181 Variable Persistence Display is being used, begin by setting the PERSISTENCE maximum counterclockwise and pushing in the WRITE button. Make the following spectrum analyzer settings.

Function	Setting
INPUT ATTEN (push knob to engage)	10 dB
REFERENCE LEVEL	0 dBm 002: +50 dBmV
REF LEVEL FINE	0
Amplitude Scale	LIN
FREQ SPAN/DIV (uncoupled)	10 MHz
RESOLUTION BW (uncoupled)	1 MHz
SWEEP TIME/DIV	AUTO
SWEEP TRIGGER	FREE RUN
START - CENTER TUNING	CENTER > 60 MHz
BASELINE CLIPPER	OFF
VIDEO FILTER	OFF
180-series mainframes: DISPLAY	INT (out)
MAGNIFIER	X1 (out)
SCALE (180TR, 182T)	OFF
PERSISTENCE (181T/TR)	MIN (ccw)
Display Mode (181T/TR)	WRITE

DISPLAY ADJUSTMENTS

1. With an adjustment tool, adjust VERTICAL POSN to place the CRT trace on a horizontal graticule line near center of CRT.
2. Reduce the INTENSITY and set the SWEEP TIME/DIV control to MAN. Adjust the MAN SWEEP knob to bring dot to center of CRT.

CAUTION

Leaving a dot on the CRT for prolonged periods at high intensity may burn the phosphor.

3. Adjust the FOCUS and ASTIG controls for the smallest round dot possible.
4. Reset the SWEEL TIME/DIV control to AUTO and increase the INTENSITY for an optimum CRT trace. Center the trace horizontally with the HORIZONTAL POSITION control. If the horizontal deflection is not exactly 10 divisions, adjust the HORIZ GAIN control (located on the spectrum analyzer rear panel) for a 10 division (wide) horizontal deflection.

NOTE

The analyzer must be removed from the mainframe to adjust the HORIZ GAIN control.

5. Adjust the TRACE ALIGN so that the CRT trace is parallel with the horizontal graticule lines.
6. Adjust the VERTICAL POSN until the trace aligns with the bottom graticule line.

FREQUENCY ADJUSTMENTS

7. Center the LO feedthrough - the 'signal' at 0 MHz - on the CRT with the TUNING control, pressing the FREQUENCY CAL pushbutton two or three times to remove tuning hysteresis in the first LO (YIG oscillator).
8. Narrow the FREQ SPAN/DIV to 200 kHz and press the FREQUENCY CAL pushbutton once more. Adjust the REF LEVEL FINE control as necessary to position the signal peak near the top CRT graticule line.
9. Re-center the LO feedthrough, if necessary, and adjust FREQUENCY ZERO to calibrate the FREQUENCY MHz readout at 00.0 MHz.

AMPLITUDE ADJUSTMENTS

10. Set the FREQ SPAN/DIV control to 1 MHz and the REF LEVEL FINE control to 0. Adjust the TUNING control for a FREQUENCY MHz readout of approximately 280 MHz.
11. Press the 10 dB/DIV Amplitude Scale pushbutton, and set the REFERENCE LEVEL control to - 20 dBm (+ 30 dBmV for Option 002).

CAUTION

The HP 8558B Options 001 and 002 feature 75-ohm (female) INPUT and CAL OUTPUT connectors. Standard 50-ohm BNC cables and adapters should not be used with these connectors since damage might result.

12. Connect the 280 MHz CAL OUTPUT to the spectrum analyzer input and center the signal on the CRT with the TUNING control, pressing the FREQUENCY CAL pushbutton two or three times. The FREQUENCY MHz readout will indicate 280 MHz + 5 MHz.

13. Press the LIN Amplitude Scale pushbutton. Adjust the REF LEVEL FINE control to place the signal peak at the top CRT graticule line.
14. Press the 10 dB/DIV Amplitude Scale pushbutton. Adjust VERTICAL GAIN to place the signal peak at the top CRT graticule line.
15. Repeat steps 12 and 13 until the signal peak remains at the top CRT graticule line when the Amplitude Scale is alternated between 10 dB/DIV and LIN.
16. Set the REF LEVEL FINE control to 0 and the REFERENCE LEVEL control to -30 dBm (+ 20 dBmV for Option 002).
17. Press the LIN Amplitude Scale pushbutton and adjust REF LEVEL CAL to place the signal peak at the top CRT graticule line.

Once the Front Panel Adjustment Procedure is completed, the spectrum analyzer is calibrated for absolute amplitude and frequency measurements. During normal operation, the FREQUENCY CAL pushbutton should be pressed whenever the tuning is changed by more than 50 MHz. This removes tuning hysteresis and ensures maximum frequency accuracy.



Figure 3-2. Rear Panel Controls and Connectors (2 of 2)

3-7/3-8 (blank)

**SECTION IV.
PERFORMANCE TESTS**

4-1. INTRODUCTION

4-2. The procedures in this section test the electrical performance of the instrument against the specifications in Section I. The performance tests included in this section are listed in Table 4-1. Most of the tests can be performed without access to the interior of the instrument. If a test measurement is marginal, perform the appropriate adjustment procedures in Section V.

Table 4-1. Performance Tests

Paragraph	Test
4-11	Frequency Span Accuracy
4-12	Tuning Accuracy
4-13	Residual FM
4-14	Noise Sidebands
4-15	Resolution Bandwidth Accuracy
4-16	Resolution Bandwidth Selectivity
4-17	Average Noise Level
4-18	Spurious Responses
4-19	Residual Responses
4-20	Frequency Response
4-21	Bandwidth Switching (Amplitude Variation)
4-22	Input Attenuator Accuracy
4-23	Reference Level Accuracy
4-24	Display Fidelity
4-25	Calibrator Accuracy

4-3. INSTRUMENTS TESTED

4-4. Since a 180-series Display mainframe is required for operation of the HP Model 8558B Spectrum Analyzer plug-in, the specifications listed in Table 1-1 apply when both instruments are functioning together. Consequently, the performance tests in this section verify the proper operation of both the HP 8558B and the 180-series Display mainframe.

4-5. EQUIPMENT REQUIRED

4-6. The equipment required for the performance tests is listed under Recommended Test Equipment in Section I. Any equipment that satisfies the critical specifications given in the table may be substituted for the recommended model.

4-7. TEST RECORD

4-8. Results of the performance tests may be tabulated in the Performance Test Record at the end of this section. The test record lists test specifications and acceptable limits.

4-9. CALIBRATION CYCLE

4-10. This instrument requires periodic calibration. Calibration should be verified every six months by means of the performance tests.

PERFORMANCE TESTS

NOTE

Perform the Front Panel Adjustment Procedure in Section III before proceeding with the performance tests. Allow at least 30 minutes warmup time.

4-11. FREQUENCY SPAN ACCURACY

SPECIFICATION

Fourteen calibrated spans from 100 MHz/div to 5 kHz/div in a 1, 2, 5 sequence. Frequency error between any two points on the display is less than - 5 % of the indicated frequency separation.

DESCRIPTION

Wide span widths are checked by using the 100-, 10-, and 1-MHz outputs from a comb generator. Narrow span widths are checked by using the output from a comb generator modulated by a function generator. Since the comb generator produces frequency components separated by a precisely determined frequency interval, the resultant spectral lines displayed on the CRT are evenly spaced when no span error exists in the instrument. Thus, span error is the cumulative variance of distance among the spectral line intervals displayed across the CRT. The amount of span error is determined by comparing the distance of the first nine graticule divisions to the display distance of the corresponding spectral line intervals.

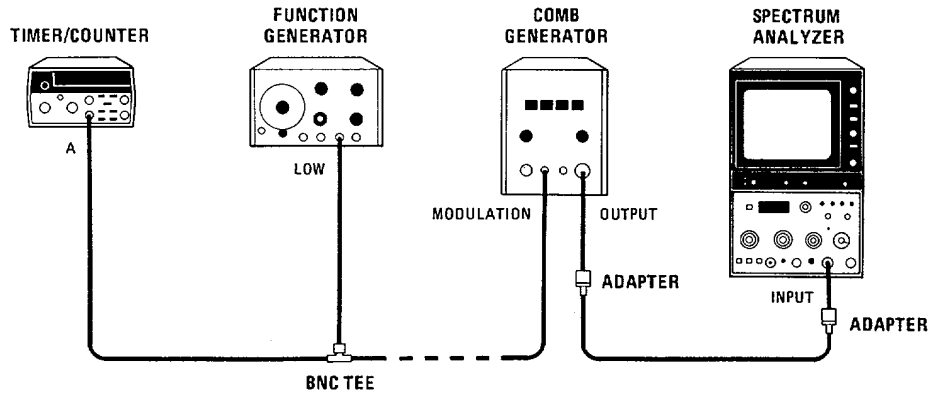

Figure 4-1. Frequency Span Accuracy Test Setup

EQUIPMENT

Comb Generator.....	HP 8406A
Timer/Counter	HP 5308A
Function Generator	HP 3310A
BNC Cable, 120 cm (48 in).....	HP 10503A
Adapter, Type N (m) to BNC (f) (2 required)	HP 1250-0780
BNC Tee	HP 1250-0781

Additional Equipment, Options 001 and 002:

Minimum Loss Adapter, 75W to 50W.....	HP 08558-60031
Adapter, BNC (m) to BNC (m), 75W.....	HP 1250-1288
Adapter, SMA (f) to SMA (f).....	HP 1250-1158
Adapter, BNC (f) to SMA (m).....	HP 1250-1200

PERFORMANCE TESTS

4-11. FREQUENCY SPAN ACCURACY(Cont'd)

PROCEDURE

- 1. Set equipment controls as follows:

Spectrum Analyzer:

START-CENTER..... CENTER
TUNING 800 MHz
FREQ SPAN/DIV 100 MHz
RESOLUTION BW OPTIMUM, coupled (pushed in)
INPUT ATTEN..... 0 dB
REFERENCE LEVEL -20 dBm
002: + 30 dBmV
Amplitude Scale 10 dB/DIV
SWEEP TIME/DIV AUTO
SWEEP TRIGGER..... FREE RUN
BASELINE CLIPPER..... OFF
VIDEO FILTER..... OFF

Comb Generator:

COMB FREQUENCY- MHz..... 100 MC
INTERPOLATION AMPLITUDE- 1 MHz OFF
OUTPUT AMPLITUDE 10 o'clock

Function Generator:

FUNCTION SINE
RANGE 10K
Frequency 200 kHz
DC OFFSET LEVEL..... 0

- 2. Connect equipment as shown in Figure 4-1 but do not connect function generator to comb generator.
3. Adjust spectrum analyzer TUNING control to position one spectral line (from comb generator) at first graticule line (left-hand edge of display). Measure error between ninth spectral line and ninth graticule line as shown in Figure 4-2. Error should be no greater than - 0.4 division.

_____ div

- 4. Set FREQ SPAN/DIV to 50 MHz. Adjust TUNING control to position one spectral line at first graticule line. Measure error between fifth spectral line and ninth graticule line. Error should be no greater than i 0.4 division.

_____ div

PERFORMANCE TESTS

4-11. FREQUENCY SPAN ACCURACY(Cont'd)

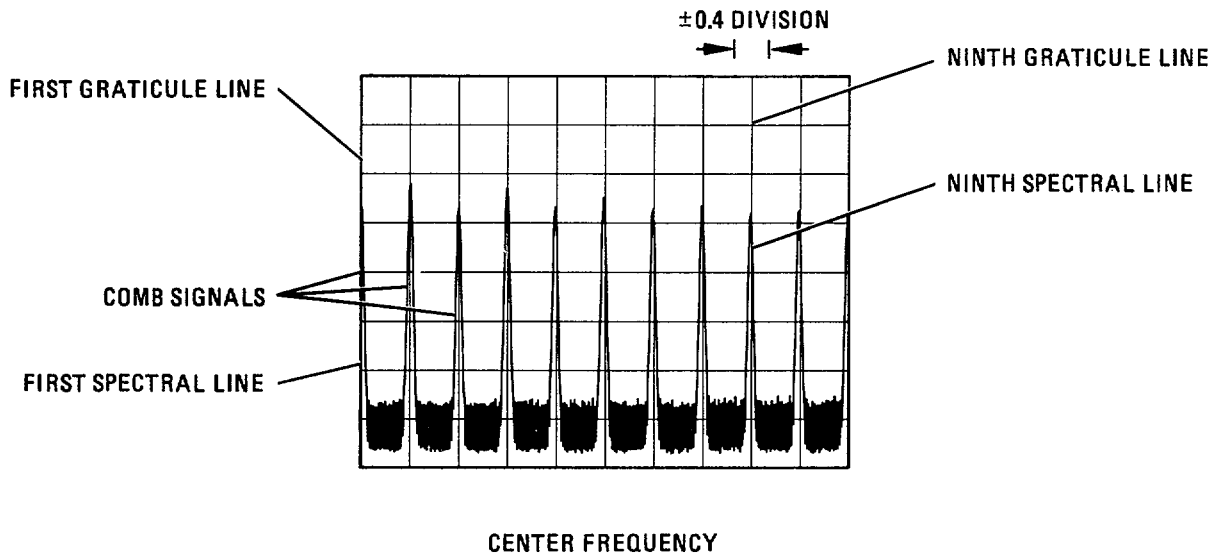

Figure 4-2. Frequency Span Accuracy Measurement for Ninth Spectral Line

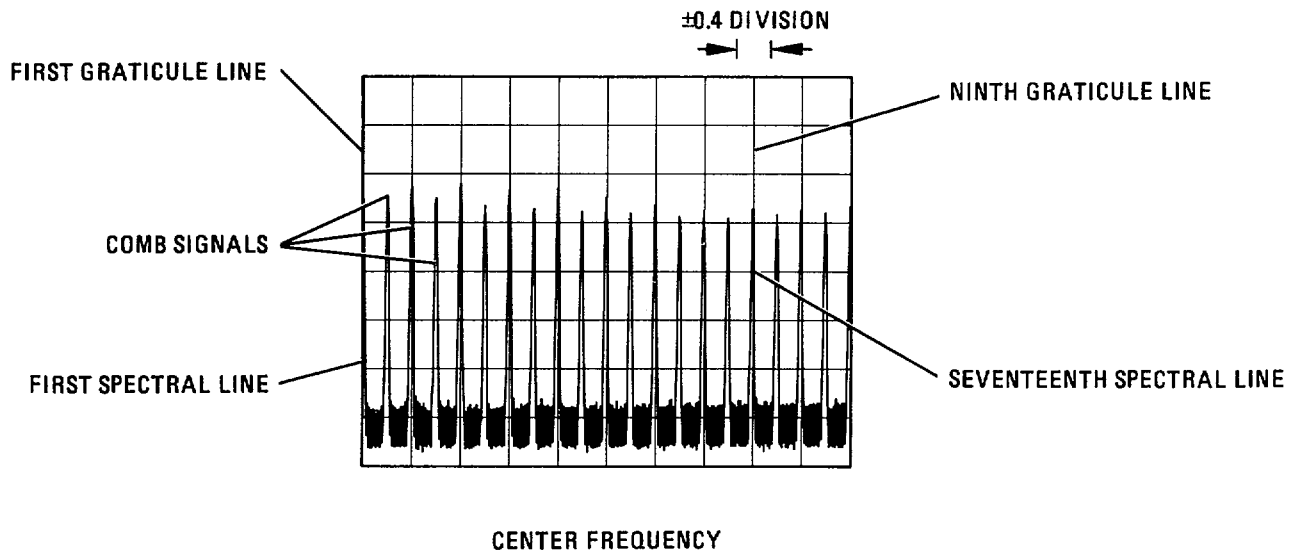

Figure 4-3. Frequency Span Accuracy Measurement for Seventeenth Spectral Line

PERFORMANCE TESTS

4-11. FREQUENCY SPAN ACCURACY(Cont'd)

5. Set comb generator COMB FREQUENCY-MHz for 10-MHz comb. Set spectrum analyzer FREQ SPAN/DIV to 20 MHz. Adjust TUNING control to position one spectral line at first graticule line. Measure error between 17th spectral line and ninth graticule line as shown in Figure 4-3. Error should be no greater than ± 0.4 division.

_____ div

6. Set FREQ SPAN/DIV to 10 MHz. Adjust TUNING control to position one spectral line at first graticule line. Measure error between ninth spectral line and ninth graticule line. Error should be no greater than ± 0.4 division.

_____ div

7. Set FREQ SPAN/DIV to 5 MHz. Adjust TUNING control to position one spectral line at first graticule line. Measure error between fifth spectral line and ninth graticule line. Error should be no greater than ± 0.4 division.

_____ div

8. Set comb generator COMB FREQUENCY-MHz for 1-MHz comb. Set spectrum analyzer FREQ SPAN/DIV to 2 MHz. Adjust TUNING control to position one spectral line at first graticule line. Measure error between 17th spectral line and ninth graticule line. Error should be no greater than ± 0.4 division.

_____ div

9. Set FREQ SPAN/DIV to 1 MHz. Adjust TUNING control to position one spectral line at first graticule line. Measure error between ninth spectral line and ninth graticule line. Error should be no greater than ± 0.4 division.

_____ div

10. Set FREQ SPAN/DIV to 500 kHz. Adjust TUNING control to position one spectral line at first graticule line. Measure error between fifth spectral line and ninth graticule line. Error should be no greater than ± 0.4 division.

_____ div

11. Set comb generator COMB FREQUENCY-MHz for 10-MHz comb. Adjust spectrum analyzer TUNING to position a spectral line at center graticule line. Turn on comb generator INTERPOLATION AMPLITUDE- 1 MHz.

12. Set function generator frequency to 200 kHz ($\pm 0.5\%$) using frequency counter. Connect function generator output to comb generator MODULATION input. Set function generator OUTPUT LEVEL for a clean 200-kHz comb on the spectrum analyzer display.
-

PERFORMANCE TESTS

4-11. FREQUENCY SPAN ACCURACY (Cont'd)

NOTE

To obtain a clean comb on the spectrum analyzer display, use the **LOW** or **HIGH** output of the function generator as necessary. Readjust the function generator **OUTPUT LEVEL** and the comb generator **INTERPOLATION AMPLITUDE - 1 MHz** as necessary.

13. Set spectrum analyzer **FREQ SPAN/DIV** to 200 kHz. Adjust **TUNING** control to position one spectral line at first graticule line. Measure error between ninth spectral line and ninth graticule line. Error should be no greater than 4 0.4 division.

_____ div

14. Using procedure of **NOTE** in step 12, vary spectrum analyzer **FREQ SPAN/DIV** and Function Generator Output Frequency in accordance with Table 4-2. Adjust spectrum analyzer **TUNING** control to position one spectral line at first graticule line. Measure span error between ninth spectral line and ninth graticule line.

Table 4-2. Narrow Span Width Error Measurement

Spectrum Analyzer		Function Generator Output Frequency*	Allowable Error (Max.)
FREQ SPAN/DIV	RESOLUTION BW		
100 kHz	OPTIMUM	100 kHz	+0.4 Division
50 kHz	OPTIMUM	50 kHz	+0.4 Division
20 kHz	OPTIMUM	20 kHz	+0.4 Division
10 kHz	OPTIMUM	10 kHz	+0.4 Division
5 kHz	OPTIMUM	5 kHz	+0.4 Division

* Check function generator output frequency using a frequency counter. Frequency readout should be within +0.5% of desired audio frequency.

PERFORMANCE TESTS

4-12. TUNING ACCURACY

SPECIFICATION

0 to 195 MHz: $\pm(1 \text{ MHz} \pm 20\% \text{ of FREQ SPAN/DIV setting})$, 10°C to 40°C

195 to 1500 MHz: $\pm(5 \text{ MHz} \pm 20\% \text{ of FREQ SPAN/DIV setting})$, 10°C to 40°C.

DESCRIPTION

A comb generator is used to provide 1-, 10-, or 100-MHz frequency components that produce spectral lines on the CRT at 1-, 10-, or 100-MHz intervals, respectively. The spectrum analyzer TUNING control is adjusted until the desired test frequency is shown on the FREQUENCY MHz readout of the Digital Panel Meter. The FREQUENCY CAL switch is pressed and the amount of readout (or tuning) error is found by measuring the distance of the spectral line offset from the center graticule line.

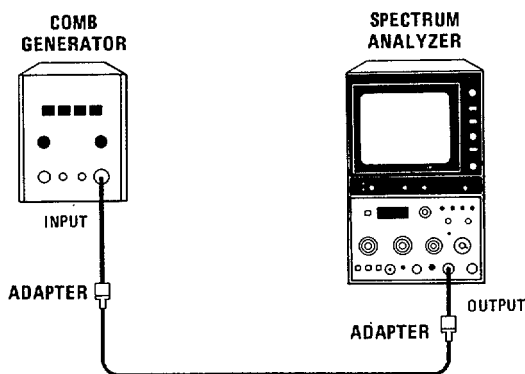

Figure 4-4. Tuning Accuracy Test Setup

EQUIPMENT

Comb Generator.....	HP 8406A
BNC Cable, 120 cm (48 in).....	HP 10503A
Adapter, Type N (m) to BNC (f) (2 required)	HP 1250-0780

Additional Equipment, Options 001 and 002:

<i>Minimum Loss Adapter, 75W to 50W.....</i>	<i>HP 08558-60031</i>
<i>Adapter, BNC (m) to BNC (m), 75W.....</i>	<i>HP 1250-1288</i>
<i>Adapter, SMA (f) to SMA (f).....</i>	<i>HP 1250-1158</i>
<i>Adapter, BNC (f) to SMA (m).....</i>	<i>HP 1250-1200</i>

PERFORMANCE TESTS

4-12. TUNING ACCURACY (Cont'd)

PROCEDURE

1. Set spectrum analyzer controls as follows:

START-CENTER..... CENTER
 FREQ SPAN/DIV 200 kHz
 RESOLUTION BW OPTIMUM
 INPUT ATTEN..... 0 dB
 REFERENCE LEVEL - 20 dBm
002: +30dBmV
 Amplitude Scale 10 dB/DIV
 SWEEP TIME/DIV AUTO
 SWEEP TRIGGER..... FREE RUN
 BASELINE CLIPPER..... OFF
 VIDEO FILTER..... OFF

2. Adjust spectrum analyzer TUNING control to position LO feedthrough signal at center graticule line of display. Press FREQUENCY CAL switch and reposition LO feedthrough signal at center graticule line, as required. Adjust FREQ ZERO control for zero indication on FREQUENCY MHz readout. LO feedthrough signal should still be positioned at center graticule line of display.

3. Connect equipment as shown in Figure 4-4.

4. Set comb generator controls as follows:

COMB FREQUENCY - MHz..... 10 MC
 INTERPOLATION AMPLITUDE- 1 MHz..... OFF
 OUTPUT AMPLITUDE 10 o'clock

5. Adjust spectrum analyzer TUNING control until FREQUENCY MHz readout indicates 10.0 MHz. Press FREQUENCY CAL switch. Comb generator spectral line, displayed on CRT, should be within 5.2 divisions (- 1.04 MHz) of center graticule line.

_____ div

NOTE

If the spectral line is off screen, set FREQ SPAN/DIV to 500 kHz and check that the spectral line is within 2.2 divisions of the center graticule line.

6. Using procedure of step 5, adjust spectrum analyzer and comb generator controls as shown in Table 4-3 to measure TUNING accuracy. After tuning to each FREQUENCY MHz readout, press FREQUENCY CAL switch before measuring TUNING accuracy.

PERFORMANCE TESTS

4-12. TUNING ACCURACY (Cont'd)

Table 4-3. Tuning Accuracy Measurement

Spectrum Analyzer		Comb Generator	Specification (Spectral line limits referenced to center graticule line) (Divisions)	
FREQUENCY MHz Readout (MHz)	FREQ SPAN/DIV. Setting	COMB FREQUENCY-MC Setting (MHz)	Min.	Max.
20.0	200 kHz	10	-5.2	+5.2
40.0	200 kHz	10	-5.2	+5.2
60.0	200 kHz	10	-5.2	+5.2
80.0	200 kHz	10	-5.2	+5.2
100.0	200 kHz	10	-5.2	+5.2
120.0	200 kHz	10	-5.2	+5.2
140.0	200 kHz	10	-5.2	+5.2
160.0	200 kHz	10	-5.2	+5.2
180.0	200 kHz	10	-5.2	+5.2
200	1 MHz	100	-5.2	+5.2
400	1 MHz	100	-5.2	+5.2
600	1 MHz	100	-5.2	+5.2
800	1 MHz	100	-5.2	+5.2
1000	1 MHz	100	-5.2	+5.2
1200	1 MHz	100	-5.2	+5.2
1400	1 MHz	100	-5.2	+5.2
1500	1 MHz	100	-5.2	+5.2

PERFORMANCE TESTS

4-13. RESIDUAL FM

SPECIFICATION

Less than 1 kHz peak-to-peak for time < 0.1 second

FM DESCRIPTION

This test measures the inherent short-term instability (residual FM) of the LO system in the spectrum analyzer. A stable signal applied to the input of the spectrum analyzer is slope-detected on the linear portion of the 10 kHz bandwidth filter in zero span (fixed-tuned receiver). (See Figure 4-6a.) Instability in the LO system is transferred to the IF signal in the mixing process. As the IF signal moves in relation to the center of the IF filter, the attenuation of the signal changes in accordance with the skirt characteristics of the filter. If the signal stays on the linear portion of the IF filter skirt, the amplitude of the IF signal applied to the final detector (and thus the level on the display) is linearly related to the frequency of the IF signal. (See Figure 4-6b). Therefore, any variations in level seen on the display are linearly related to variations in LO frequency.

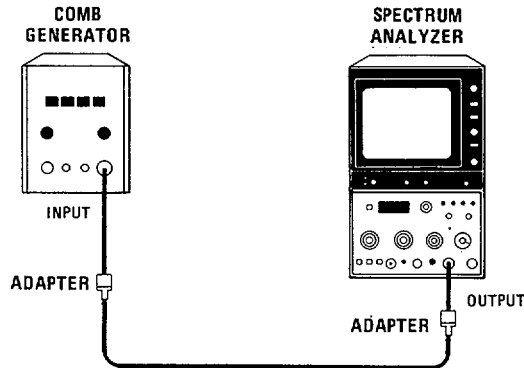

Figure 4-5. Residual FM Test Setup

EQUIPMENT

- Comb Generator..... HP 8406A
- BNC Cable, 120 cm (48 in)..... HP 10503A
- Adapter, Type N (m) to BNC (f) (2 required) HP 1250-0780

Additional Equipment, Options 001 and 002:

- Minimum Loss Adapter, 75W to 50W..... HP 08558-60031
- Adapter, BNC (m) to BNC (m), 75W..... HP 1250-1288
- Adapter, SMA (f) to SMA (f)..... HP 1250-1158
- Adapter, BNC (f) to SMA (m)..... HP 1250-1200

PERFORMANCE TESTS

4-13. RESIDUAL FM (Cont'd)

a. Residual FM in Zero Span

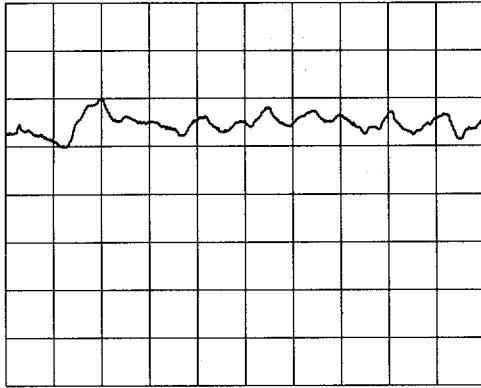

b. Shape of 10 kHz Resolution BW Filter

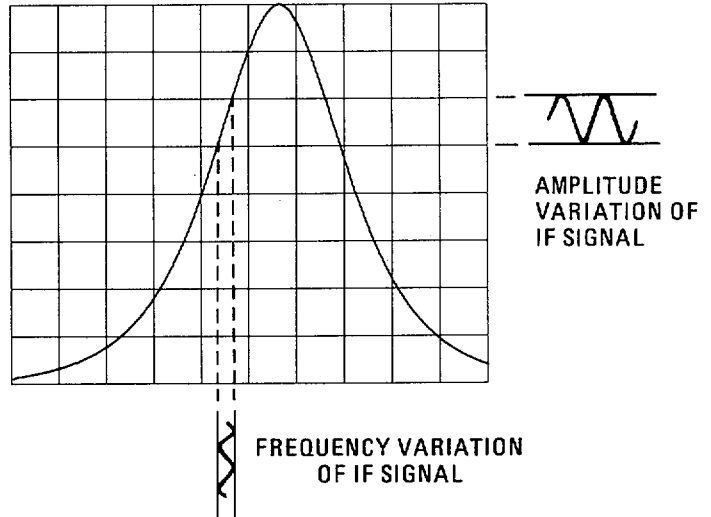

Figure 4-6. Example of Residual FM

PROCEDURE

1. Set spectrum analyzer and comb generator controls as follows:

Spectrum Analyzer:

START-CENTER..... CENTER
 FREQUENCY SPAN/DIV 100 kHz
 RESOLUTION BW 10kHz
 INPUT ATTEN..... 0 dB
 REFERENCE LEVEL - 20 dBm
 002: +30dBmV
 Amplitude Scale LIN
 SWEEP TIME/DIV AUTO
 SWEEP TRIGGER..... FREE RUN
 BASELINE CLIPPER..... OFF
 VIDEO FILTER..... OFF

Comb Generator:

COMB FREQUENCY - MHz..... 100 MC
 INTERPOLATION AMPLITUDE- 1 MHz..... OFF
 OUTPUT AMPLITUDE Fully clockwise

PERFORMANCE TESTS

4-13. RESIDUAL FM (Cont'd)

2. Connect OUTPUT of comb generator to spectrum analyzer INPUT connector as shown in Figure 4-5.

NOTE

The HP 8558B is sensitive to vibration. Be sure the instrument is in a vibration-free environment.

3. Adjust spectrum analyzer TUNING control to display 500-MHz signal produced by comb generator. Adjust REFERENCE LEVEL and REF LEVEL FINE controls to position peak of signal at top graticule line.
4. Keep 500-MHz signal centered on CRT while reducing FREQ SPAN/DIV to zero.
5. Set RESOLUTION BW to 10 kHz and SWEEP TIME/DIV to .1 SEC.
6. Slightly readjust fine TUNING control of spectrum analyzer until trace appears between fourth and seventh graticule lines. Peak-to-peak variation of trace should not exceed one major vertical division for each major horizontal division. (See Figure 4-6a.)

_____ div

PERFORMANCE TESTS

4-14. NOISE SIDEBANDS

SPECIFICATION

More than 65 dB below CW signal, 50 kHz or more away from signal with a 1-kHz resolution bandwidth and full video filtering.

DESCRIPTION

A stable 400-MHz CW signal is applied at a - 20 dBm level to the spectrum analyzer and is displayed on the CRT. The test is designed to measure the amplitude of noise-associated sidebands and unwanted responses.

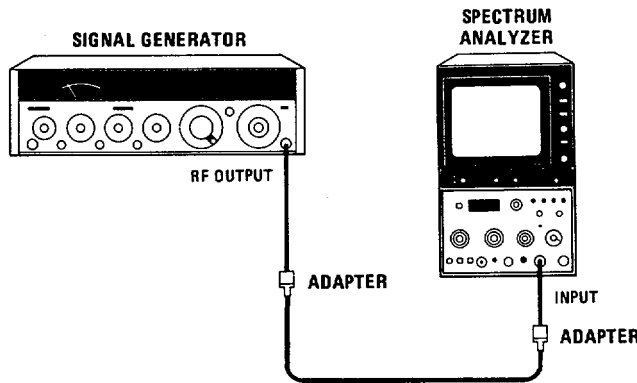

Figure 4-7. Noise Sideband Test Setup

EQUIPMENT

Signal Generator	HP 8640B
BNC Cable, 120 cm (48 in).....	HP 10503A
Adapter, Type N (m) to BNC (f) (2 required)	HP 1250-0780

Additional Equipment, Options 001 and 002:

Minimum Loss Adapter, 75W to 50W.....	HP 08558-60031
Adapter, BNC (m) to BNC (m), 75W.....	HP 1250-1288
Adapter, SMA (f) to SMA (f).....	HP 1250-1158
Adapter, BNC (f) to SMA (m).....	HP 1250-1200

PERFORMANCE TESTS

4-14. NOISE SIDEBANDS(Cont'd)

PROCEDURE

1. Set equipment controls as follows:

Spectrum Analyzer:

START-CENTER..... CENTER
 TUNING 400MHz
 FREQUENCY SPAN/DIV 1 MHz
 RESOLUTION BW 30 KHz
 INPUT ATTEN..... 10 dB
 REFERENCE LEVEL - 20 dBm
002: +30dBmV
 Amplitude Scale10 dB/DIV
 SWEEP TIME/DIV AUTO
 SWEEP TRIGGER..... FREE RUN
 BASELINE CLIPPER..... OFF
 VIDEO FILTER..... OFF

Signal Generator

FREQUENCY 400 MHz
 RF OUTPUT - 20 dBm
 RF ON
 AM OFF
 FM OFF

2. Connect equipment as shown in Figure 4-7.
3. Adjust TUNING control to locate 400-MHz signal on CRT.
4. Adjust REFERENCE LEVEL and REF LEVEL FINE controls to position peak of 400-MHz signal at top graticule line.
5. Decrease FREQ SPAN/DIV to 20 kHz and RESOLUTION BW to 1 kHz. Adjust TUNING to keep signal centered.
6. Position signal at center of display. Turn VIDEO FILTER control fully clockwise (not in detent). Measure noise sidebands existing more than 2.5 division (50 kHz) from 400-MHz signal. Noise sidebands should be greater than 65 dB (6.5 divisions) down from top graticule line.

_____ div down

PERFORMANCE TESTS

4-15. RESOLUTION BANDWIDTH ACCURACY

SPECIFICATION

Individual resolution bandwidth 3-dB points calibrated to 20%o (10°C to 400C)

DESCRIPTION

Resolution bandwidth accuracy is measured in the linear mode to eliminate log amplifier errors. Since signal level at the 3-dB points (half-power points) is related to peak signal level by a voltage ratio of 0.707:1.0, a peak level of 7.1 vertical divisions on the spectrum analyzer display gives a half-power level of 5 vertical divisions:

$$0.707 \text{ (voltage ratio)} = X \text{ div}/7.1 \text{ div}$$

$$X \text{ div} = (7.1)(0.707)$$

$$\approx 5 \text{ div}$$

In the 30-, 10-, and 1-kHz bandwidths, a 301.4-MHz signal (second IF) is injected into A9 Third Converter Assembly to provide the stability required for measurement of narrow resolution bandwidths.

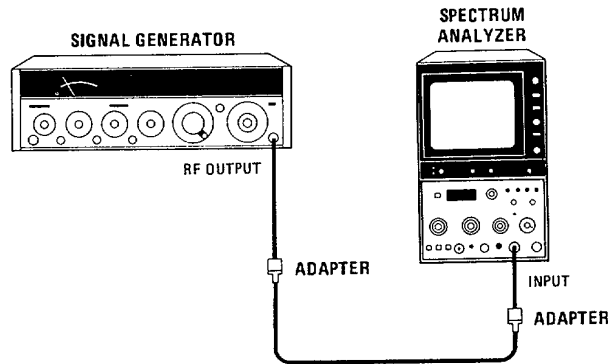

Figure 4-8. Resolution Bandwidth Accuracy Test Setup, 3 MHz to 100 kHz

EQUIPMENT

Signal Generator	HP 8640B
Extender Cable Assembly	HP 5060-0303
Adapter, SMC (m) to BNC (m).....	HP 1250-0831
Adapter, BNC (f) to BNC (f).....	HP 1250-0080
Adapter, Type N (m) to BNC (f) (2 required)	HP 1250-0780
BNC Cable, 120 cm (48 in).....	HP 10503A

Additional Equipment, Options 001 and 002:

Minimum Loss Adapter, 75W to 50W.....	HP 08558-60031
Adapter, BNC (m) to BNC (m), 75W.....	HP 1250-1288
Adapter, SMA (f) to SMA (f).....	HP 1250-1158
Adapter, BNC (f) to SMA (m).....	HP 1250-1200

PERFORMANCE TESTS

4-15. RESOLUTION BANDWIDTH ACCURACY(Cont'd) ,

PROCEDURE

WARNING

This test must be performed with power supplied to the instrument and with protective covers removed. The test should be performed only by service-trained personnel who are aware of the hazards involved.

- 1. Set equipment controls as follows:

Spectrum Analyzer:

START-CENTER..... CENTER
TUNING 10 MHz
FREQUENCY SPAN/DIV 0
RESOLUTION BW 3 MHz
INPUT ATTEN..... 20 dB
REFERENCE LEVEL 0 dBm
002: +30dBmV
Amplitude Scale LIN
SWEEP TIME/DIV 5 mSEC
SWEEP TRIGGER..... FREE RUN
BASELINE CLIPPER..... OFF
VIDEO FILTER..... OFF

Signal Generator

COUNTER MODE..... INT, EXPAND X10
AM OFF
FM OFF
FREQUENCY TUNE 10 MHz
RF ON
OUTPUT LEVEL 0 dBm

- 2. Connect equipment as shown in Figure 4-8.
3. Adjust spectrum analyzer TUNING control to locate peak of 10-MHz signal on CRT. Reduce signal generator output if necessary.
4. Adjust signal generator OUTPUT LEVEL to position trace at 7.1 divisions above graticule baseline.
5. Tune signal generator frequency until trace drops to 5 divisions above graticule baseline. Record signal generator frequency.

_____ MHz

PERFORMANCE TESTS

4-15. RESOLUTION BANDWIDTH ACCURACY(Cont'd)

6. Tune signal generator frequency in direction opposite to that of step 5 until trace peaks (7.1 divisions above graticule baseline) and then drops to 5 divisions above graticule baseline. Record signal generator frequency.

_____ MHz

7. Calculate and record resolution bandwidth at 3-dB points (difference between frequencies recorded in steps 5 and 6).

Min.	Actual	Max.
2.40 MHz	_____	3.60 MHz

8. Set RESOLUTION BW to 1 MHz, leaving FREQ SPAN/DIV set to 0. Set signal generator to 10 MHz and repeat steps 3 through 7.

Min.	Actual	Max.
800 kHz	_____	1200 kHz

9. Set RESOLUTION BW to 300 kHz, leaving FREQ SPAN/DIV set to 0. Set signal generator to 10 MHz and repeat steps 3 through 7.

Min.	Actual	Max.
240 kHz	_____	360 kHz

10. Set RESOLUTION BW to 100 kHz, leaving FREQ SPAN/DIV set to 0. Set signal generator to 10 MHz and repeat steps 3 through 7.

Min.	Actual	Max.
80 kHz	_____	120 kHz

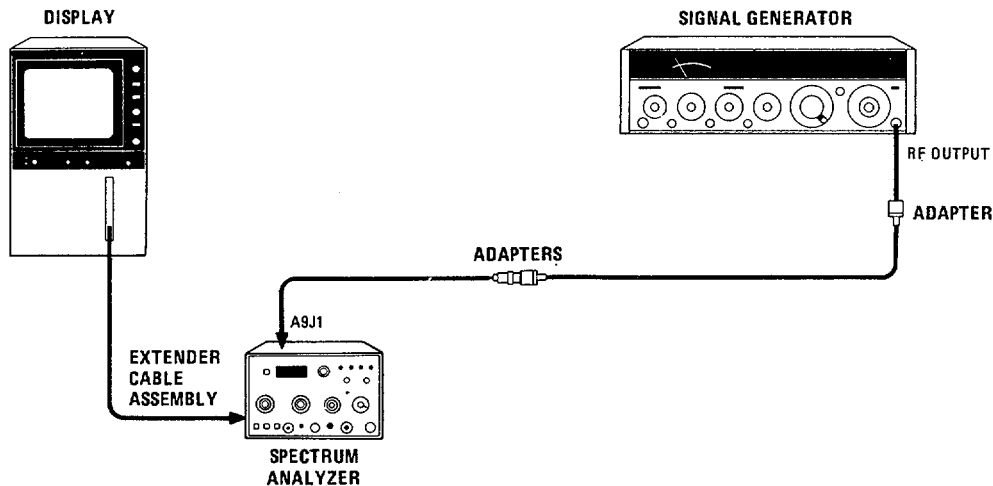

Figure 4-9. Resolution Bandwidth Accuracy Test Setup, 1 kHz to 30 kHz

PERFORMANCE TESTS

4-15. RESOLUTION BANDWIDTH ACCURACY(Cont'd)

WARNING

In the following procedure, the plug-in must be removed from the display mainframe and connected through the extender cable assembly. Be very careful; the energy at some points in the instrument might, if contacted, cause personal injury. This test should be performed only by a skilled person who knows the hazard involved.

- 11. Set signal generator OUTPUT LEVEL to approximately -12 dBm and tune frequency to 301.4 MHz. Set COUNTER MODE to EXPAND X100.
- 12. Set spectrum analyzer INPUT ATTEN to 0 dB and REFERENCE LEVEL to -10 dBm. Set RESOLUTION BW to 30 kHz. Leave FREQ SPAN/DIV set to 0.

002: REFERENCE LEVEL, + 40 dBmV.

- 13. Connect equipment as shown in Figure 4-9. Remove W7P1 from A10OJ2. Connect signal generator through adapters to W7P1.
- 14. Adjust signal generator frequency until spectrum analyzer trace is at peak. Set signal generator OUTPUT LEVEL to position trace at 7.1 divisions above graticule baseline.
- 15. Tune signal generator frequency until trace drops to 5 divisions above graticule baseline. Record signal generator frequency.

_____ MHz

- 16. Tune signal generator frequency in direction opposite to that of step 15 until trace peaks and then drops to 5 divisions above graticule baseline. Record signal generator frequency.

_____ MHz

- 17. Calculate and record resolution bandwidth at 3-dB points (difference between frequencies recorded in steps 15 and 16).

Min.	Actual	Max.
24 kHz	_____	36 kHz

- 18. Set RESOLUTION BW to 10 kHz, leaving FREQ SPAN/DIV set to 0. Repeat steps 14 through 17.

Min.	Actual	Max.
8 kHz	_____	12 kHz

PERFORMANCE TESTS

4-15. RESOLUTION BANDWIDTH ACCURACY(Cont'd) ,

19. Set RESOLUTION BW to 3 kHz, leaving FREQ SPAN/DIV set to 0. Repeat steps 14 through 17.

Min.	Actual	Max.
2.4 kHz	_____	3.6 kHz

20. Set RESOLUTION BW to 1 kHz, leaving FREQ SPAN/DIV set to 0. Repeat steps 14 through 17.

Min.	Actual	Max.
0.8 kHz	_____	1.2 kHz

21. Reconnect W7P1 to A10J2 unless continuing on with next performance test.

PERFORMANCE TESTS

4-16. RESOLUTION BANDWIDTH SELECTIVITY**SPECIFICATION**

60-dB:3-dB resolution bandwidth ratio < 15:1.

DESCRIPTION

The 60-dB bandwidth is measured for all resolution bandwidths. The 60- to 3-dB resolution bandwidth ratio (shape factor) is then computed for each bandwidth by dividing the 3-dB value (from the Resolution Bandwidth Accuracy test) into the 60-dB value.

In the 30-, 10-, and 1-kHz bandwidths, a 301.4-MHz signal (second IF) is injected into A9 Third Converter assembly to provide the stability required for the measurement of narrow resolution bandwidths.

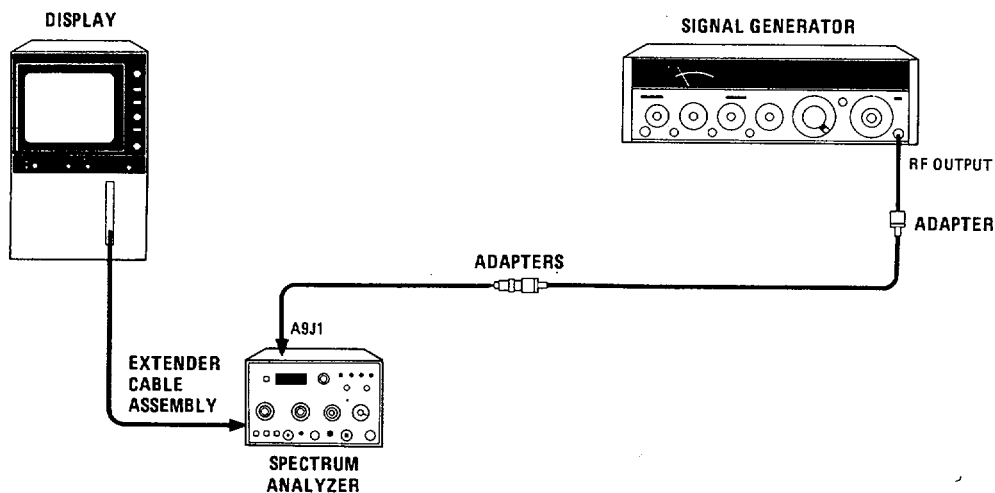

Figure 4-10. Resolution Bandwidth Selectivity Test Setup, 1 kHz to 30 kHz

WARNING

In the following procedure, the plug-in must be removed from the display mainframe and connected through the extender cable assembly. Be very careful; the energy at some points in the instrument might, if contacted, cause personal injury. This test should be performed only by a skilled person who knows the hazard involved.

PERFORMANCE TESTS

4-16. RESOLUTION BANDWIDTH SELECTIVITY(Cont'd)

EQUIPMENT

Signal Generator	HP 8640B
Extender Cable Assembly	HP 5060-0303
Adapter, SMC (m) to BNC (m)	HP 1250-0831
Adapter, BNC (f) to BNC (f)	HP 1250-0080
Adapter, Type N (m) to BNC (f) (2 required)	HP 1250-0780
BNC Cable, 120 cm (48 in)	HP 10503A

Additional Equipment, Options 001 and 002:

<i>Minimum Loss Adapter, 75Ω to 50Ω</i>	<i>HP 08558-60031</i>
<i>Adapter, BNC (m) to BNC (m), 75Ω</i>	<i>HP 1250-1288</i>
<i>Adapter, SMA (f) to SMA (f)</i>	<i>HP 1250-1158</i>
<i>Adapter, BNC (f) to SMA (m)</i>	<i>HP 1250-1200</i>

PROCEDURE

1. Set equipment controls as follows:

Spectrum Analyzer

START-CENTER	CENTER
TUNING	50 MHz
FREQ SPAN/DIV	0
RESOLUTION BW	1 kHz
INPUT ATTEN	0 dB
REFERENCE LEVEL	-10 dBm
002: + 40 dBm V	
Amplitude Scale	10 dB/DIV
SWEEP TIME/DIV	5 mSEC
SWEEP TRIGGER	FREE RUN
BASELINE CLIPPER	OFF
VIDEO FILTER	OFF

Signal Generator

COUNTER MODE	INT, EXPAND X10
AM	OFF
FM	OFF
FREQUENCY TUNE	301.4 MHz
RF	ON
OUTPUT LEVEL	-20 dBm

2. Connect equipment as shown in Figure 4-10. Remove W7P1 from A10J2. Connect signal generator through adapters to W7P1.
3. Adjust signal generator frequency until spectrum analyzer trace is at peak. Set signal generator OUTPUT LEVEL to position trace at top graticule line.

PERFORMANCE TESTS

4-16. RESOLUTION BANDWIDTH SELECTIVITY(Cont'd)

4. Tune signal generator until trace drops to 2 divisions above graticule baseline. Record signal generator frequency.
_____MHz
5. Tune signal generator in direction opposite to that of step 4 until trace peaks and then drops to 2 divisions above graticule baseline. Record signal generator frequency.
_____MHz
6. Calculate and record resolution bandwidth at 60-dB points (difference between frequencies recorded in steps 4 and 5).
_____kHz
7. Set RESOLUTION BW to 3 kHz, leaving FREQ SPAN/DIV set to 0. Repeat steps 3 through 6.
_____kHz
8. Set RESOLUTION BW to 10 kHz, leaving FREQ SPAN/DIV set to 0. Repeat steps 3 through 6.
_____kHz
9. Set spectrum analyzer RESOLUTION BW to 30 kHz, leaving FREQ SPAN/DIV set to 0. Repeat steps 3 through 6.
_____kHz
10. Reconnect W7P1 to A10J2. Set display LINE power to OFF and remove extender cable assembly. Install plug-in in mainframe and set LINE power to ON.
11. Set signal generator OUTPUT LEVEL to 0 dBm.
12. Set spectrum analyzer INPUT ATTEN to 20 dB and REFERENCE LEVEL to 0 dBm. Set RESOLUTION BW to 100 kHz, leaving FREQ SPAN/DIV set to 0.
002: REFERENCE LEVEL, +50 dBmV.
13. Connect equipment as shown in Figure 4-11.
14. Set signal generator frequency to 50 MHz. Adjust spectrum analyzer TUNING to locate peak of 50-MHz signal on CRT.
15. Adjust signal generator OUTPUT LEVEL to position trace at top graticule line.

PERFORMANCE TESTS

4-16. RESOLUTION BANDWIDTH SELECTIVITY (Cont'd)

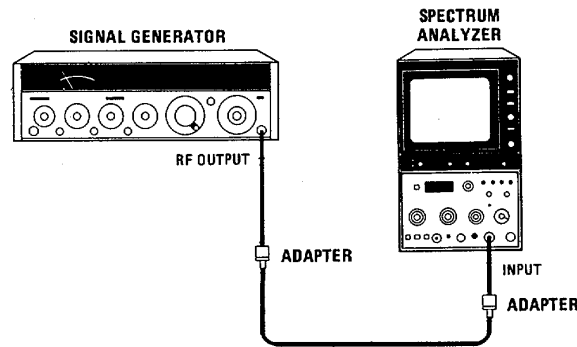

Figure 4-11. Resolution Bandwidth Selectivity Test Setup, 100 kHz to 3 MHz

16. Tune signal generator frequency until trace drops to 2 divisions above graticule baseline. Record signal generator frequency.

_____ MHz
17. Tune signal generator frequency in direction opposite to that of step 16 until trace peaks and then drops to 2 divisions above graticule baseline. Record signal generator frequency.

_____ MHz
18. Calculate and record resolution bandwidth at 60-dB points (difference between frequencies recorded in steps 16 and 17).

_____ kHz
19. Set spectrum analyzer RESOLUTION BW to 300 kHz, leaving FREQ SPAN/DIV set to 0. Repeat steps 14 through 18.

_____ kHz
20. Set RESOLUTION BW to 1 MHz, leaving FREQ SPAN/DIV set to 0. Repeat steps 14 through 18.

_____ MHz
21. Set RESOLUTION BW to 3 MHz, leaving FREQ SPAN/DIV set to 0. Repeat steps 14 through 18.

_____ MHz
22. In Table 4-4, record 3-dB bandwidths computed in Resolution Bandwidth Accuracy test.
23. In Table 4-4, record 60-dB bandwidths recorded in this procedure.
24. For each resolution bandwidth, divide 60-dB bandwidth by 3-dB bandwidth to obtain Resolution Bandwidth Ratio. Each ratio should be less than 15:1.

PERFORMANCE TESTS

4-16. RESOLUTION BANDWIDTH SELECTIVITY (Cont'd)

Table 4-4. Resolution Bandwidth Selectivity

RESOLUTION BW Setting	MEASURED 3 db BW	MEASURED 60 db BW	Resolution Bandwidth Ration (60 db BW): (3 dB BW)
3 MHz	_____	_____	_____
1 MHz	_____	_____	_____
300 kHz	_____	_____	_____
100 kHz	_____	_____	_____
30 kHz	_____	_____	_____
10 kHz	_____	_____	_____
3 kHz	_____	_____	_____
1 kHz	_____	_____	_____

PERFORMANCE TESTS

4-17. AVERAGE NOISE LEVEL

SPECIFICATION

Less than - 107 dBm with a 10-kHz resolution bandwidth (0 dB input attenuation), 1 MHz to 1500 MHz.

- 001: Less than - 100dBm
- 002: Less than - 53 dBm V

DESCRIPTION

The average noise level is checked by observing the average noise power level displayed on the CRT when no input signal is applied to the instrument. The test is performed with a 10-kHz resolution bandwidth.

PROCEDURE

1. Set spectrum analyzer controls as follows:

START-CENTER.....	CENTER
TUNING	500 MHz
FREQ SPAN/DIV.....	100 MHz
RESOLUTION BW	10 kHz
INPUT ATTEN.....	0dB
REFERENCE LEVEL	- 60 dBm
002:-10 dBm V	
Amplitude Scale	10 dB/DIV
SWEEP TIME/DIV.....	10 mSEC
SWEEP TRIGGER.....	FREE RUN
BASELINE CLIPPER.....	OFF
VIDEO FILTER.....	12 o'clock

2. Adjust TUNING until LO feedthrough is not on screen. Set VIDEO FILTER to MAX (not in detent) and observe CRT display of noise level from 1 MHz to 1000 MHz. Noise level, as shown in Figure 4-12, should be less than - 107.

- 001: Change '- 107 dBm' to '- 100 dBm' throughout procedure and in Figure 4-12.
- 002: Change '- 107 dBm' to '- 53 dBmV' throughout procedure and in Figure 4-12.

_____ < - 107 dBm

3. Set START-CENTER switch to START. Observe average noise level from 500 MHz to 1500 MHz. Noise level should be less than - 107 dBm.

_____ < - 107 dBm

PERFORMANCE TESTS

4-17. AVERAGE NOISE LEVEL(Cont'd)

4. Set START-CENTER switch to CENTER and FREQ SPAN/DIV to 1 MHz. Adjust TUNING for a FREQUENCY MHz readout of 6 MHz and momentarily press FREQUENCY CAL switch.
5. Observe average noise level from 1 MHz to 11 MHz. Noise level should be less than - 107 dBm.

_____ < - 107 dBm

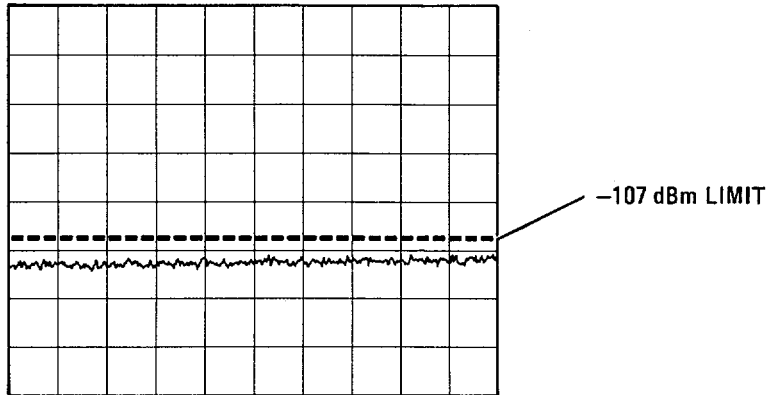

Figure 4-12. Average Noise Level Measurement

PERFORMANCE TESTS

4-18. SPURIOUS RESPONSES

SPECIFICATION

Image and multiple responses and second harmonic distortion products are > 70 dB* below a -40 dBm in-put signal with 0 dB input attenuation.

001: -35 dBm input signal

002: $+15$ dBmV input signal

Third order intermodulation distortion products are >70 dB* below two -30 dBm input signals, separated by ≥ 50 kHz, with 0 dB input attenuation.

001: two -25 dBm input signals

002: two $+25$ dBm V input signals

* > 60 dB for 100 kHz to 5 MHz input signals.

DESCRIPTION:

A signal source with a lowpass filter is used to measure harmonic distortion. The LPF is required to ensure that the signals displayed on the CRT are due to harmonic distortion in the spectrum analyzer rather than to the harmonic content of the signal generator.

In measuring spurious responses due to image frequencies, out-of-band responses, and intermodulation distortion, signals from two separate sources are applied to the spectrum analyzer.

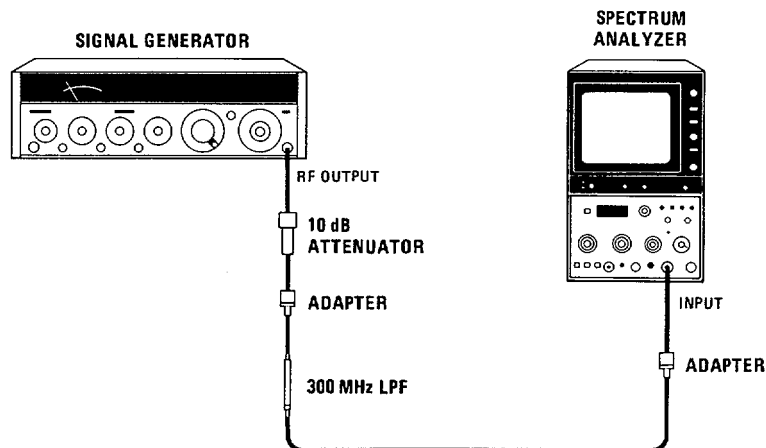

Figure 4-13. Harmonic Distortion Test Setup

PERFORMANCE TESTS

4-18. SPURIOUS RESPONSES (Cont'd)

EQUIPMENT

Signal Generator (2 required)	HP 8640B
10 dB Attenuator (2 required).....	HP 8491A Opt. 010
300 MHz LPF.....	Telonic TLP 300-4AB
BNC Tee.....	HP 1250-0781
Adapter, Type N (m) to BNC (f) (3 required)	HP 1250-0780
BNC Cable, 120 cm (48 in) (2 required)	HP 10503A

Additional Equipment, Options 001 and 002:

<i>Minimum Loss Adapter, 75Ω to 50W</i>	<i>HP 08558-60031</i>
<i>Adapter, BNC(m) to BNC(m), 75W.....</i>	<i>HP 1250-1288</i>
<i>Adapter, SMA (f) to SMA (f).....</i>	<i>HP 1250-1158</i>
<i>Adapter, BNC (f) to SMA (m)</i>	<i>HP 1250-1200</i>

PROCEDURE

Harmonic Distortion

1. Set spectrum analyzer controls as follows:

START-CENTER.....	CENTER
TUNING	280 MHz
FREQ SPAN/DIV.....	500 kHz
RESOLUTION BW	30 kHz
INPUT ATTEN.....	0 dB
REFERENCE LEVEL.....	-40 dBm
001: -30 dBm	
002: + 20 dBm V	
REF LEVEL FINE	0
001: -5	
002: -5	
Amplitude Scale	10 dB/DIV
SWEEP TIME/DIV.....	AUTO
SWEEP TRIGGER.....	FREE RUN
BASELINE CLIPPER.....	OFF
VIDEO FILTER.....	12 o'clock

2. Set signal generator frequency to 280 MHz and OUTPUT LEVEL to - 30 dBm.
3. Connect equipment as shown in Figure 4-13.
4. Momentarily press FREQUENCY CAL switch. Tune signal generator to center signal on spectrum analyzer display.

PERFORMANCE TESTS

4-18. SPURIOUS RESPONSES (Cont'd)

5. Adjust signal generator OUTPUT LEVEL for -40 dBm displayed at top graticule line of spectrum analyzer CRT.

001: -35 dBm
 002: + 15 dBm V

6. Increase signal generator OUTPUT LEVEL by 20 dB.

7. Set spectrum analyzer TUNING to approximately 560 MHz and identify second harmonic.

8. Center signal on spectrum analyzer display and reduce signal generator OUTPUT LEVEL by 20 dB.

9. Set spectrum analyzer RESOLUTION BW to 3 kHz. Harmonics should be more than 70 dB below input signal (below first graticule line from bottom).

2nd Harmonic: _____ dB

3rd Harmonic: _____ dB

10. Set RESOLUTION BW to 30 kHz. Increase signal generator OUTPUT LEVEL by 20 dB.

11. Set spectrum analyzer TUNING to approximately 840 MHz and identify third harmonic.

12. Repeat steps 8 and 9.

Intermodulation Distortion

13. Set spectrum analyzer controls as follows:

START-CENTER CENTER
 TUNING 30 MHz
 FREQ SPAN/DIV 500 kHz
 RESOLUTION BW 30 kHz
 INPUT ATTEN 0 dB
 REFERENCE LEVEL - 30 dBm
 001: -20dBm
 002: +30dBm V
 REF LEVEL FINE 0
 001: -5
 002: -5
 Amplitude Scale 10 dB/DIV
 SWEEP TIME/DIV AUTO
 SWEEP TRIGGER FREE RUN
 BASELINE CLIPPER OFF
 VIDEO FILTER 12 o'clock

PERFORMANCE TESTS

4-18. SPURIOUS RESPONSES(Cont'd)

14. Connect equipment as shown in Figure 4-14.

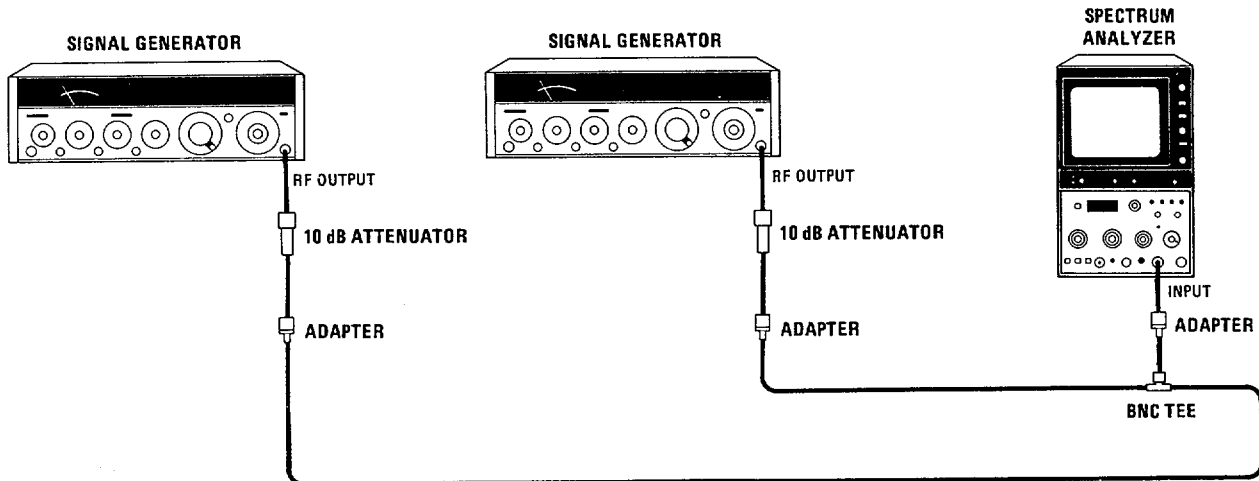

Figure 4-14. Intermodulation Distortion Test Setup

15. Set both signal generators for approximately 30 MHz output at - 24 dBm.
16. Momentarily press FREQUENCY CAL switch. Tune signal generators until signals are 2 divisions apart and centered on display.
17. Adjust OUTPUT LEVEL controls of both signal generators for - 30 dBm displayed on spectrum analyzer.

001: -25 dBm
002: + 25 dBm V

18. Reduce spectrum analyzer RESOLUTION BW to 3 kHz and check for third order intermodulation distortion products at approximately 3 divisions to either side of center graticule line (see NOTE below). They should be more than 70 dB below input signals (-100 dBm on spectrum analyzer display). (See Figure 4-15.)

001: - 95 dBm on spectrum analyzer display
002: - 50 dBmV on spectrum analyzer display

NOTE

_____dB

If the intermodulation distortion product cannot be located, increase output levels of both signal generators by 10 dB. Be sure to return the OUTPUT LEVEL of each signal generator to its previous setting before making the actual measurement.

PERFORMANCE TESTS

4-18. SPURIOUS RESPONSES(Cont'd)

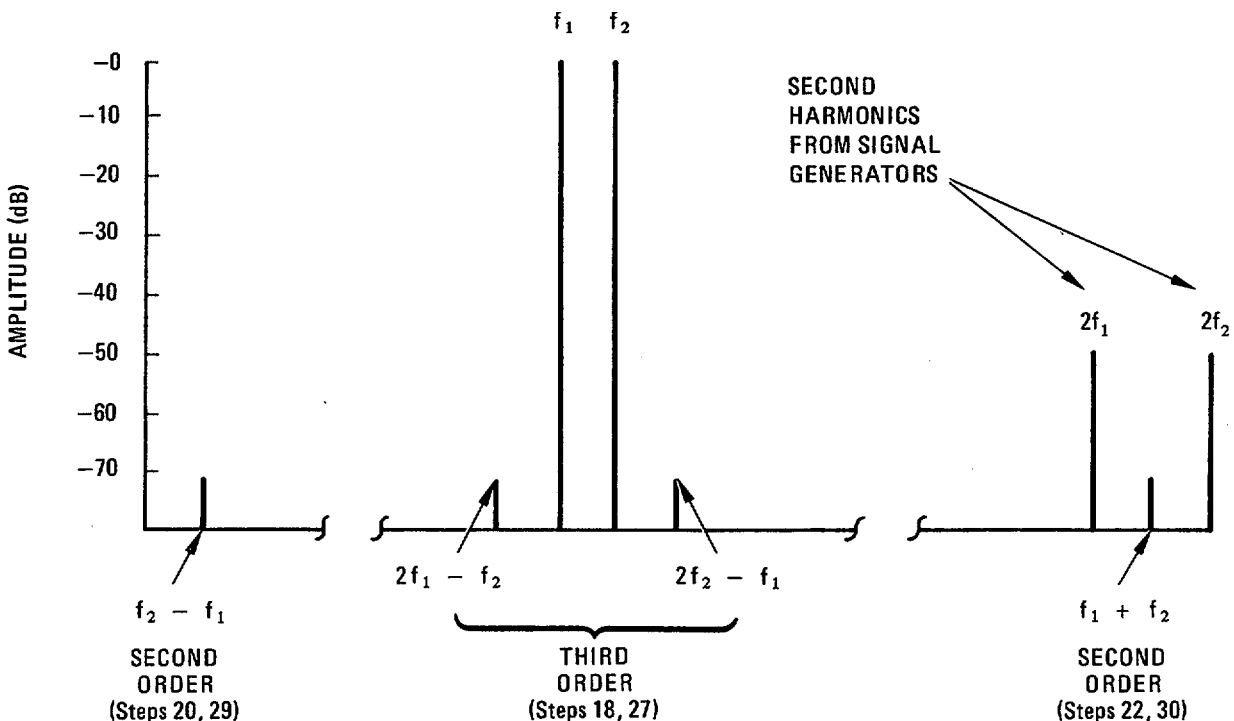

Figure 4-15. Intermodulation Distortion Products

19. Set INPUT ATTEN to 0 dB, REFERENCE LEVEL to -40 dBm, and RESOLUTION BW to 30 kHz. Adjust OUTPUT LEVEL of each signal generator to -43 dBm as displayed on CRT.

001: REFERENCE LEVEL - 35 dBm; output level of -38 dBm displayed on CRT

002: REFERENCE LEVEL + 15 dBmV; output level of +12 dBmV displayed on CRT

20. Set spectrum analyzer TUNING to 1 MHz and momentarily press FREQUENCY CAL switch. Set RESOLUTION BW to 3 kHz and adjust VIDEO FILTER as necessary for more than 70 dB display range. Check for second order intermodulation distortion product ($f_2 - f_1$) near center of display (see NOTE below). Second order intermodulation distortion product should be more than 60 dB below the total applied signal (-100 dBm on spectrum analyzer display). (See Figure 4-15.)

001: -95 dBm on spectrum analyzer display

002: -45 dBmV on spectrum analyzer display

NOTE

If the intermodulation distortion product cannot be located, increase output levels of both signal generators by 10 dB. Be sure to return the OUTPUT LEVEL of each signal generator to its previous setting before making the actual measurement.

PERFORMANCE TESTS

4-18. SPURIOUS RESPONSES (Cont'd)

- 21. Set spectrum analyzer TUNING to 60 MHz and RESOLUTION BW to 30 kHz. Momentarily press FREQUENCY CAL switch.
- 22. Check for second order intermodulation distortion product ($f_1 + f_2$) between $2f_1$ and $2f_2$ signals (see NOTE below). Set RESOLUTION BW to 3 kHz and adjust VIDEO FILTER as necessary for more than 70 dB display range. Second order intermodulation distortion product should be more than 70 dB below total applied signal (- 110 dBm on spectrum analyzer display). (See Figure 4-15.)

001: - 105 dBm on spectrum analyzer display
 002: - 60 dBm V on spectrum analyzer display

NOTE

If the intermodulation distortion product cannot be located, increase output levels of both signal generators by 10 dB. Be sure to return the OUTPUT LEVEL of each signal generator to its previous setting before making the actual measurement.

- 23. Set spectrum analyzer controls as follows:

START-CENTER.....	CENTER
TUNING	4 MHz
FREQ SPAN/DIV.....	500 kHz
RESOLUTION BW	30 kHz
INPUT ATTEN.....	0 dB
REFERENCE LEVEL.....	- 30 dBm
001: - 20 dBm	
002: +30dBmV	
REF LEVEL FINE.....	0
001: -5	
002: -5	
Amplitude Scale	10 dB/DIV
SWEEP TIME/DIV.....	AUTO
SWEEP TRIGGER.....	FREE RUN
BASELINE CLIPPER.....	OFF
VIDEO FILTER.....	12 o'clock

- 24. Set both signal generators for approximately 4 MHz at - 24 dBm.
- 25. Momentarily press FREQUENCY CAL switch. Tune signal generators until signals are 2 divisions apart and centered on display.
- 26. Adjust OUTPUT LEVEL of each signal generator for - 30 dBm as displayed on CRT.

001: - 25 dBm
 002: + 25 dBm V

PERFORMANCE TESTS

4-18. SPURIOUS RESPONSES(Cont'd)

27. Check for third order intermodulation distortion products at approximately 3 divisions from either side of center graticule line. Third order intermodulation distortion products should be more than 60 dB below input signals (- 90 dBm on spectrum analyzer display).

001: - 85 dBm on spectrum analyzer display
 002: - 35 dBm V on spectrum analyzer display

NOTE

_____dB

If signal generators other than HP 8640's are used, intermodulation distortion might be in the generators themselves because of crosstalk between the two sources.

28. Set INPUT ATTEN to 0 dB and REFERENCE LEVEL to -40 dBm. Adjust OUTPUT LEVEL of each signal generator for - 43 dBm as displayed on CRT.

001: REFERENCE LEVEL, - 35 dBm; output level of - 38 dBm displayed on CRT
 002: REFERENCE LEVEL, + 15 dBmV; + 12 dBmV as displayed on CRT

29. Set spectrum analyzer TUNING to 1 MHz and momentarily press FREQUENCY CAL switch. Set RESOLUTION BW to 3 kHz and adjust VIDEO FILTER as necessary for more than 70 dB display range. Check for second order intermodulation distortion product ($f_2 - f_1$) near center of display (see NOTE below). Second order intermodulation distortion product should be more than 60 dB below total applied signal (-100 dBm on spectrum analyzer display). (See Figure 4-15.)

001: - 95 dBm on spectrum analyzer display
 002: - 45 dBm V on spectrum analyzer display

_____dB

NOTE

If the intermodulation distortion product cannot be located, increase output levels of both signal generators by 10 dB. Be sure to return the OUTPUT LEVEL of each signal generator to its previous setting before making the actual measurement.

30. Set spectrum analyzer TUNING to 8 MHz and check for second order intermodulation distortion product ($f_1 + f_2$) between $2f_1$ and $2f_2$ signals. (See figure 4-15.) Second order intermodulation distortion product should be more than 60 dB below total applied signal (- 100 dBm on spectrum analyzer display). (See NOTE above.)

001: - 95 dBm on spectrum analyzer display
 002: - 45 dBmV on spectrum analyzer display

_____dB

PERFORMANCE TESTS

4-19. RESIDUAL RESPONSES

SPECIFICATION

< - 100 dBm (1-1500 MHz) with 0 dB input attenuation and no signal present at input.

- 001: < - 95 dBm
- 002: < - 50 dBmV

DESCRIPTION

The spectrum analyzer is tested for residual responses with no signal applied to the INPUT 509 connector. The input attenuation is set to 0 dB.

001 and 002: INPUT 75W

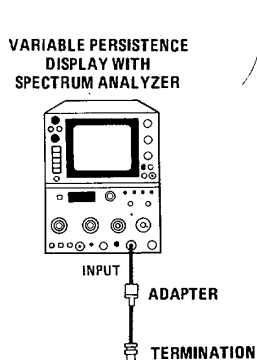

Figure 4-16. Residual Responses Test Setup

EQUIPMENT

- Variable Persistence/Storage Display HP 181T
- 50-Ohm Termination..... HP 11593A

001 and 002: 75-Ohm Termination, HP 11652-60010

PROCEDURE

1. Set spectrum analyzer controls as follows:

- START-CENTER CENTER
- TUNING 500 MHz
- FREQ SPAN/DIV 100 MHz
- RESOLUTION BW 1 MHz
- INPUT ATTEN 0 dB
- REFERENCE LEVEL - 60 dBm
- 002: - 10 dBm V
- Amplitude Scale 10 dB/DIV
- SWEEP TIME/DIV AUTO
- SWEEP TRIGGER FREE RUN
- VIDEO FILTER Fully clockwise (not in detent)

PERFORMANCE TESTS

4-19. RESIDUAL RESPONSES (Cont'd)

2. Terminate INPUT 501 connector with 50-ohm coaxial termination (see Figure 4-16).
001 and 002: 75W; 75-ohm
3. With variable persistence display in NORM mode, set LO feedthrough to far left vertical graticule line. Set BASELINE CLIPPER to 3 o'clock.
4. Set HP 181T to WRITE mode. Set PERSISTENCE control to MAX and INTENSITY control to approximately 12 o'clock.
5. Set spectrum analyzer SWEEP TRIGGER to SINGLE sweep mode and RESOLUTION BW to 30 kHz. Momentarily press ERASE pushbutton.

NOTE

When the ERASE pushbutton is pressed, the spectrum analyzer sweep might be triggered. To stop the sweep, turn SWEEP TRIGGER control clockwise.

6. Turn SWEEP TRIGGER control clockwise to initiate sweep.
7. Slowly turn BASELINE CLIPPER control until peaks of trace begin to appear on display. It might be necessary to increase baseline clipping slightly near end of sweep to reduce blooming.
8. Trigger sweep at least one more time and check for residual responses from 1 to 1000 MHz. Record frequency at which residual response of greatest amplitude appears.
_____MHz
9. Set display to NORM mode. Set spectrum analyzer BASELINE CLIPPER fully counterclockwise and SWEEP TRIGGER to FREE RUN.
10. Set FREQ SPAN/DIV to 20 kHz and TUNING to center frequency of residual recorded in step 8.
11. Narrow FREQ SPAN/DIV and RESOLUTION BW, using TUNING control to keep signal centered. Use SWEEP TIME/DIV control to reduce sweep speed until signal level does not rise when sweep speed is further reduced. Residual response must be less than - 100 dBm.
_____dBm

001: < - 95 dBm
002: < - 50 dBmV

12. Repeat steps 1 through 5.
 13. Set START-CENTER switch to START and repeat steps 6 and 7.
-

PERFORMANCE TESTS

4-19. RESIDUAL RESPONSES(Cont'd)

14. Trigger sweep at least one more time and check for residual responses from 500 MHz to 1500 MHz. Record frequency at which residual response of greatest amplitude appears.

_____MHz

15. Repeat step 9.

16. Set spectrum analyzer FREQ SPAN/DIV to 20 kHz and TUNING to center frequency of residual recorded in step 14.

17. Narrow FREQ SPAN/DIV and RESOLUTION BW, using TUNING control to keep signal centered. Use SWEEP TIME/DIV control to reduce sweep speed until signal level does not rise when sweep speed is further reduced. Residual response must be less than - 100 dBm.

_____dBm

001: < - 95 dBm
002: < - 50 dBm V

PERFORMANCE TESTS

4-20. FREQUENCY RESPONSE

SPECIFICATION

$\leq \pm 1.0$ dB with 10 dB input attenuation

DESCRIPTION

Signals from 0.1 to 1500 MHz are applied to the input of the spectrum analyzer. The amplitude of each signal is adjusted to a reference set on the analyzer display. The power level, measured with a power meter, determines the frequency response of the spectrum analyzer.

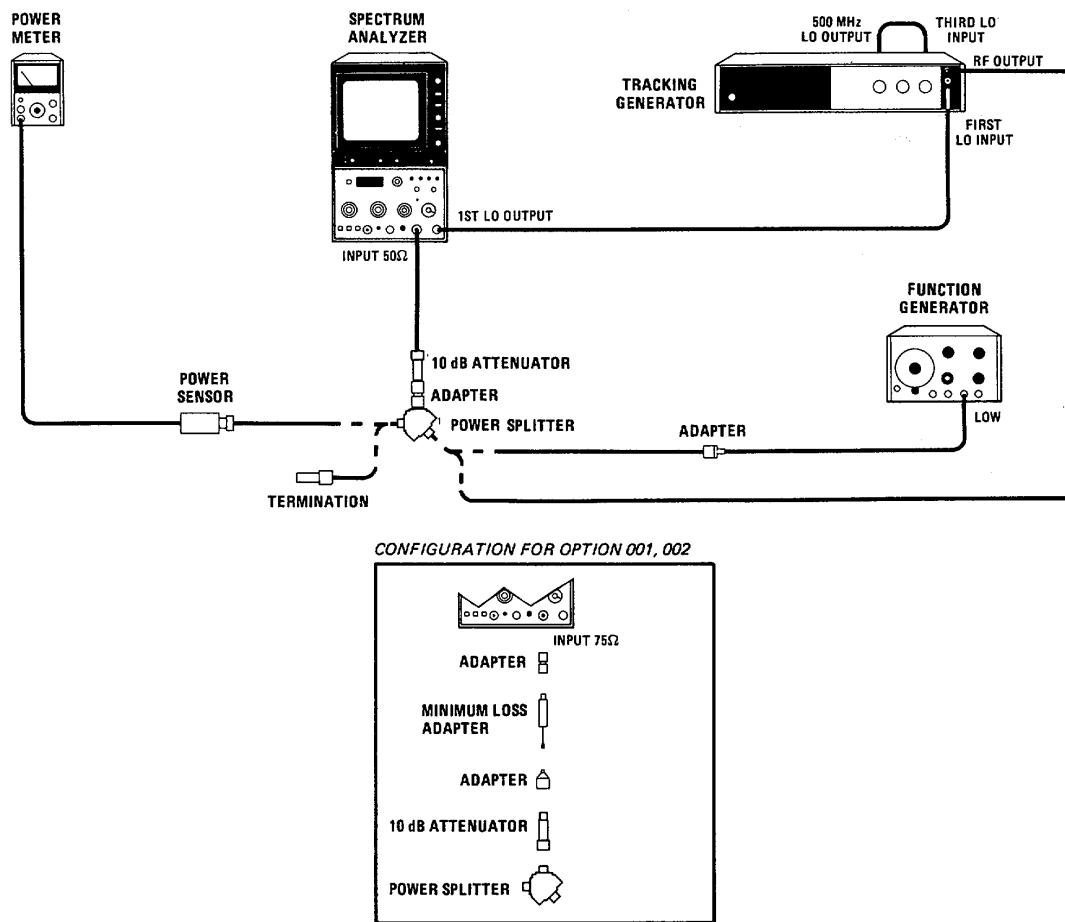

Figure 4-17. Frequency Response Test Setup

PERFORMANCE TESTS

4-20. FREQUENCY RESPONSE(Cont'd)

EQUIPMENT

Tracking Generator.....	HP 8444A Opt. 059
Power Meter	HP 435B
Power Sensor	HP 8482A
Function Generator.....	HP 3310A
Power Splitter	HP 11667A
BNC Cable, 20 cm (9 in).....	HP 10502A
BNC Cable, 120 cm (48 in).....	HP 10503A
Type N cable, 180 cm (72 in).....	HP 11500A
10 dB Attenuator.....	HP 8491B Opt. 010
Adapter, Type N (m) to Type N (m).....	HP 1250-1475
Adapter, Type N (m) to BNC (f)	HP 1250-0780

Additional Equipment, Options 001 and 002:

<i>Adapter, BNC (m) to BNC (m), 75W.....</i>	<i>HP 1250-1288</i>
<i>Adapter, Type N (m) to SMA (f), 50W.....</i>	<i>HP 1250-1250</i>
<i>Minimum Loss Adapter, 75W to 50W</i>	<i>HP 08558-60031</i>

PROCEDURE

1. Set controls as follows:

Spectrum Analyzer:

START- CENTER.....	CENTER
TUNING	0
FREQ SPAN/DIV.....	0
RESOLUTION BW	100 kHz
INPUT ATTEN.....	10 dB
REFERENCE LEVEL.....	-10 dBm
002: + 40 dBmV	
Amplitude Scale	10 dB/DIV
SWEEP TIME/DIV.....	AUTO
SWEEP TRIGGER.....	FREE RUN
BASELINE CLIPPER.....	OFF
VIDEO FILTER.....	OFF

2. Adjust spectrum analyzer TUNING to peak LO feedthrough signal on display. Press FREQUENCY CAL and readjust TUNING for peak. Repeat. Adjust TUNING for peak and adjust FREQUENCY ZERO for a FREQUENCY MHz reading of 00.0.
3. Adjust TUNING for a FREQUENCY MHz reading of 5.0 MHz. Press FREQUENCY CAL. Set up equipment as shown in Figure 4-17. Connect the tracking generator 500 MHz LO OUTPUT to the THIRD LO INPUT (rear panel).
4. Set spectrum analyzer Amplitude Scale to 1 dB/DIV and adjust REF LEVEL FINE to bring the trace on the display. Peak the trace using tracking generator TRACK ADJ.

PERFORMANCE TESTS

4-20. FREQUENCY RESPONSE(Cont'd)

5. Set power meter CAL FACTOR according to chart on power probe (5 MHz). Set RANGE to - 10 dBm.
6. Adjust tracking generator LEVEL to set a reference of - 12 dBm on the power meter.
7. Adjust spectrum analyzer REF LEVEL FINE to position trace to fourth graticule line.
8. For each setting in Table 4-5:
 - a. Adjust spectrum analyzer TUNING and press FREQUENCY CAL.
 - b. Set power meter CAL FACTOR.
 - c. Adjust tracking generator TRACK ADJ to peak signal on display and adjust LEVEL to place signal on reference graticule.
 - d. Record Power Meter Reading.
9. Disconnect Type N cable from power splitter. Connect function generator LOW output to power splitter.
10. Set controls as follows:

Spectrum Analyzer	
FREQ SPAN/DIV	50 kHz
RESOLUTION BW	10 kHz
Amplitude Scale	10 dB/DIV
Function Generator:	
RANGE	100 kHz
Frequency	5 MHz
FUNCTION	SINE
DC OFFSET	0

11. Set power meter CAL FACTOR according to chart on power sensor (5 MHz). Adjust spectrum analyzer TUNING to center 5 MHz signal on display. Set amplitude scale to 1 dB/DIV.
12. Adjust function generator OUTPUT LEVEL to - 12 dB on power meter.
13. Adjust REF LEVEL FINE to bring the peak of the 5 MHz signal to fourth graticule from bottom.
14. For each frequency in Table 4-6, set function generator frequency and tune spectrum analyzer to bring signal to center screen. Adjust function generator OUTPUT LEVEL to bring signal peak to reference graticule on the display. Set the power meter CAL FACTOR and record the power indicated by the power meter.
15. Find the overall maximum power reading from both Table 4-5 and Table 4-6.

_____dBm

PERFORMANCE TESTS

4-20. FREQUENCY RESPONSE (Cont'd)

16. Find the overall minimum power reading from both Table 4-5 and Table 4-6.

_____ dBm

17. The difference between the overall maximum power in step 15 and the overall minimum power in step 16 should be less than 2 dB.

_____ dB

Table 4-5. Frequency Response, 5 MHz to 1500 MHz

Spectrum Analyzer TUNING (MHz)	Power Meter Reading (dBm)
5	-12(Ref.)
100	_____
200	_____
300	_____
400	_____
500	_____
600	_____
700	_____
800	_____
900	_____
1000	_____
1100	_____
1200	_____
1300	_____
1400	_____
1500	_____

Table 4-6. Frequency Response, 100 kHz to 5 MHz

Spectrum Analyzer/Function Generator Frequency	Power Meter Reading (dBm)
5 MHz	-12 (Ref.)
3 MHz	_____
1 MHz	_____
500 kHz	_____
100 kHz	_____

PERFORMANCE TESTS

4-21. BANDWIDTH SWITCHING (AMPLITUDE VARIATION)

SPECIFICATION

3 MHz to 300 kHz: $\leq \pm 0.5$ dB
 3 MHz to 1 kHz: $\leq \pm 1.0$ dB (100 kHz bandwidth limited to < 80o R.H.)

DESCRIPTION

The spectrum analyzer 280 MHz CAL OUTPUT signal is applied to the INPUT connector and displayed on the CRT. The peak of the displayed 280 MHz signal is centered on the CRT and adjusted for a vertical deflection of seven divisions. The amplitude variation of the 280 MHz signal is measured for each RESOLUTION BW control setting. The overall variation between RESOLUTION BW settings of 3 MHz to 300 kHz should be equal to or less than 1 dB (± 0.5 dB). The overall variation between RESOLUTION BW settings of the 3 MHz to 1 kHz should be equal to or less than 2 dB (± 1.0 dB).

EQUIPMENT

BNC Cable, 20 cm (9 in) HP 10502A
 Adapter, Type N (m) to BNC (f) HP 1250-0780

Additional Equipment, Options 001 and 002:

Minimum Loss Adapter, 75W to 50W HP08558-60031
Adapter, BNC(m) to BNC(m), 75W HP 1250-1288
Adapter, SMA (f) to SMA (f) HP 1250-1158
Adapter, BNC (f) to SMA (m) HP 1250-1200

PROCEDURE

1. Set spectrum analyzer controls as follows:

START- CENTER CENTER
 TUNING 280 MHz
 FREQ SPAN/DIV 1 MHz
 RESOLUTION BW 3 MHz
 INPUT ATTEN 0 dB
 REFERENCE LEVEL -20 dBm
 002: + 30 dBm
 REF LEVEL FINE -10
 Amplitude Scale 1 dB/DIV
 SWEEP TIME/DIV AUTO
 SWEEP TRIGGER FREE RUN
 BASELINE CLIPPER OFF
 VIDEO FILTER OFF

2. Connect spectrum analyzer CAL OUTPUT signal to INPUT 50Ω connector.
 001 and 002: 75W

PERFORMANCE TESTS

4-21. BANDWIDTH SWITCHING (AMPLITUDE VARIATION) (Cont'd)

3. Set TUNING control, as required, to center 280 MHz signal on CRT.
4. Set REF LEVEL FINE control to position peak of 280 MHz signal seven divisions above graticule baseline.
5. Vary the RESOLUTION BW and FREQ SPAN/DIV controls in accordance with Table 4-7. Record the change in amplitude for each RESOLUTION BW setting. Changes in amplitude above reference level set in step 4 are positive (+). Changes below reference level are negative (-).

Table 4-7. Amplitude Accuracy, Switching Between Bandwidths

RESOLUTION BW Setting	FREQ SPAN/DIV Setting	Change in Amplitude (dB)	Overall Variation Between 3 MHz and 300 kHz RESOLUTION BW Settings (dB)	Overall Variation Between 3 MHz and 1 HZ RESOLUTION BW Settings (dB)
3 MHz 1 MHz 300 kHz	1 MHz 500 kHz 100 KH	0 (Ref) _____ _____	_____	_____
100 kHz 30 kHz 10 kHz 3 kHz 1 kHz	50 kHz 10 KHz 5 kHz 5 kHz 5 kHz	_____ _____ _____ _____ _____		

6. To find the overall variation in Table 4-7, algebraically subtract the greatest negative change in amplitude from the greatest positive change in amplitude. If all changes in amplitude are of the same sign, the overall variation is the largest positive or largest negative change in amplitude. The overall variation between 3 MHz and 300 kHz RESOLUTION BW settings should be ≤ 1.0 dB (± 5.0 dB). The overall variation between 3 MHz and 1 kHz RESOLUTION BW settings should be ≤ 2.0 dB (± 1.0 dB).

PERFORMANCE TESTS

4-22. INPUT ATTENUATOR ACCURACY

SPECIFICATION

Accuracy ± 0.5 dB for each 10 dB step but not more than ± 1.0 dB over full 70 dB range.

DESCRIPTION

The input attenuator accuracy is tested over its full 70 dB range using an RF substitution method. A step attenuator that has been calibrated by a Standards Laboratory at 30 MHz is used for substitution. The known error of the calibrated attenuator is taken into account when computing the 8558B input attenuator accuracy.

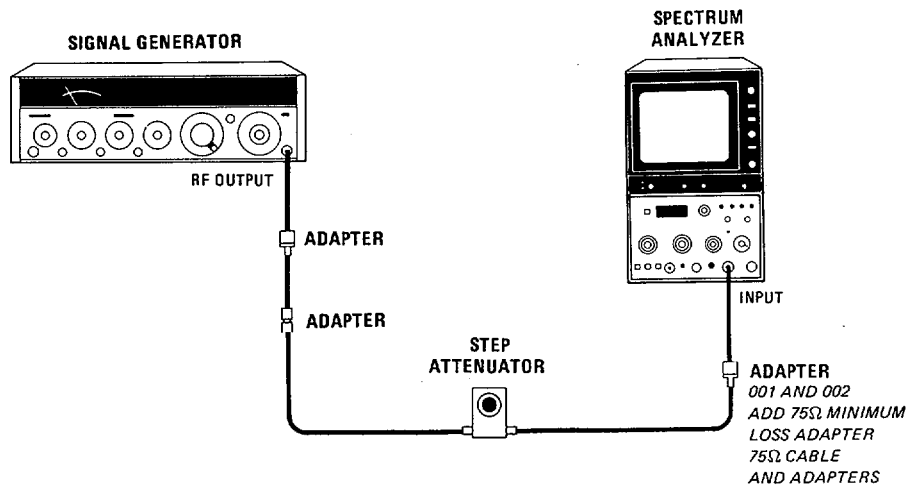

Figure 4-18. Input Attenuator Accuracy Test Setup

EQUIPMENT

Signal Generator	HP 8640B
Step Attenuator.....	HP 355D Opt. H82
Adapter, Type N (m) to BNC (f) (2 required)	HP 1250-0780
Adapter, BNC (m) to BNC (m)	HP 1250-0216
BNC Cable, 120 cm (48 in)	HP 10503A

Additional Equipment, Options 001 and 002:

Minimum Loss Adapter, 75W to 50W	HP 08558-60031
Adapter, BNC (m) to BNC (m).....	HP 1250-0216
Adapter, BNC (f) to SMA (m)	HP 1250-1200
Adapter, SMA (f) to SMA (f).....	HP 1250-1158
BNC Cable, 30cm (12 in), 75W.....	HP 11652-60012

PERFORMANCE TESTS

4-22 INPUT ATTENUATOR ACCURACY(Cont'd)

PROCEDURE

1. Set controls as follows:

Spectrum Analyzer

START - CENTER CENTER
 TUNING 30 MHz
 FREQ SPAN/DIV 200 kHz
 RESOLUTION BW 30 kHz
 INPUT ATTEN 70 dB
 REFERENCE LEVEL 0 dBm
 001: -10dBm
 002: +40dBmV
 Amplitude Scale 1 dB/DIV
 SWEEP TIME/DIV AUTO
 SWEEP TRIGGER FREE RUN
 BASELINE CLIPPER OFF
 VIDEO FILTER 2 o'clock

Signal Generator

COUNTER MODE INT
 AM OFF
 FM OFF
 FREQUENCY TUNE 30.0 MHz
 OUTPUT LEVEL 0 dBm
 RF ON

2. Connect equipment as shown in Figure 4-18 with step attenuator set at 0 dB. Locate signal on CRT and adjust signal generator OUTPUT LEVEL until signal peak is 6 divisions above graticule baseline.
3. Set HP 8558B INPUT ATTEN control and step attenuator to settings indicated in Table 4-8. Record deviation from sixth division reference set in step 2 for each setting.

Table 4-8. Input Attenuator Accuracy

INPUT ATTEN Setting (dBm)	Step Attenuator Setting (db)	Deviation from 6 th Division (db)	Step Attenuator Error (Calibration)	Corrected Deviation (db)
70	0	0 (Ref.)	Ref.	0 (Ref.)
60	10	_____	_____	_____
50	20	_____	_____	_____
40	30	_____	_____	_____
30	40	_____	_____	_____
20	50	_____	_____	_____
10	60	_____	_____	_____
0	70	_____	_____	_____

*Attenuations > dial settings are positive (+). Attenuations < dial settings are negative (-). For example, 9.99 dB calibration for a 10 dB attenuator setting represents an error of -0.01 dB.

PERFORMANCE TESTS

4-22. INPUT ATTENUATOR ACCURACY(Cont'd)

4. To compute Corrected Deviation, add Step Attenuator Error to Deviation from 6th Division for each setting. Corrected Deviation should not differ more than 0.5 dB between any two adjacent settings of input attenuator.

_____ Error Between Adjacent Settings

5. Record maximum positive and maximum negative Corrected Deviation values. Difference between these two values (total deviation) should not exceed 2.0 dB (± 1.0 dB).

_____ dB Maximum Positive Corrected Deviation
_____ dB Maximum Negative Corrected Deviation
_____ dB Total Corrected Deviation

PERFORMANCE TESTS

4-23. REFERENCE LEVEL ACCURACY

SPECIFICATION

Step Accuracy:

Steps referenced with 0 dB input attenuation

-10 dBm to - 80 dBm: ± 0.5 dB

-10 dBm to - 100 dBm: ± 1.0 dB

Vernier Accuracy:

± 0.5 dB

DESCRIPTION

The reference level accuracy is tested over the range of - 10 dBm to - 100 dBm by checking the IF gain steps in 1 dB/DIV (Log) and in LIN. The resulting maximum deviation in each case must be less than 1.0 dB (± 0.5 dB) from - 10 dBm to - 80 dBm and less than 2.0 dB (+ 1.0 dB) from - 10 dBm to - 100 dBm.

002: Change range to + 40 dBm V to - 50 dBm V.

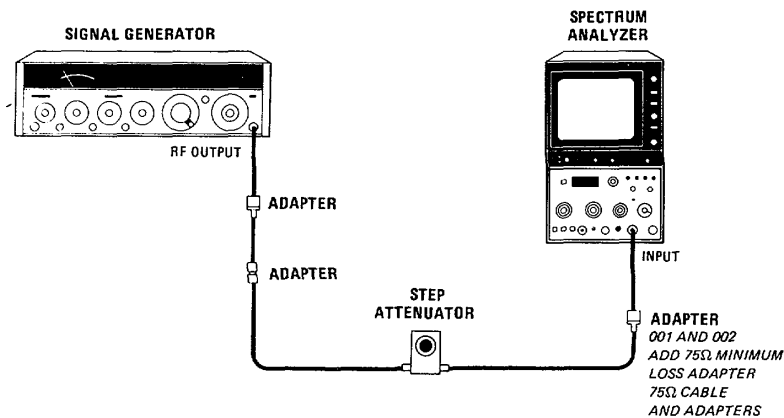

Figure 4-19. Reference Level Accuracy Test Setup

EQUIPMENT

Signal Generator	HP 8640B
1 dB Step Attenuator	HP 355C Opt. H80
10 dB Step Attenuator.....	HP 355D Opt. H82
Adapter (2 required).....	HP 1250-0780
BNC Cable, 20 cm (9 in).....	HP 10502A
BNC Cable, 120 cm (48 in)	HP 10503A

Additional Equipment, Options 001 and 002:

Minimum Loss Adapter, 75W to 50W	HP 08558-60031
Adapter, BNC (m) to BNC (m), 75W.....	HP 1250-1288
Adapter, SMA (f) to SMA (f).....	HP 1250-1158
Adapter, BNC (f) to SMA (m)	HP 1250-1200

PERFORMANCE TESTS

4-23. REFERENCE LEVEL ACCURACY (Cont'd)

PROCEDURE

Step Accuracy in Log Mode

1. Set controls as follows:

Spectrum Analyzer	
START - CENTER	CENTER
TUNING	30 MHz
FREQ SPAN/DIV	5 kHz
RESOLUTION BW	3 kHz
INPUT ATTEN	0 dB
REFERENCE LEVEL dBm	-10 dBm
<i>002: +40dBmV</i>	
Amplitude Scale	1 dB/DIV
SWEEP TIME/DIV	AUTO
SWEEP TRIGGER	FREE RUN
BASELINE CLIPPER	OFF
VIDEO FILTER	2 o'clock
Signal Generator	
COUNTER MODE	INT
AM	OFF
FM	OFF
FREQUENCY TUNE	30 MHz
OUTPUT LEVEL	-10 dBm

2. Connect equipment in Figure 4-19 with step attenuator set at 0 dB. Locate signal on CRT.

NOTE

If signal is difficult to locate, press RESOLUTION BW control to couple with FREQ SPAN/DIV control and turn the coupled controls clockwise until signal appears on display. Momentarily depress FREQ CAL switch and center the signal, using TUNING control. Return controls to positions called out in step 1, adjusting TUNING control as necessary to keep signal centered.

3. Adjust signal generator OUTPUT LEVEL until trace is 6 divisions above graticule baseline. Set the 8558B REFERENCE LEVEL control and step attenuator to settings indicated in Table 4-9. Record the Deviation from the 6th Division (reference set in step 2) for each setting.
4. To compute the Corrected Deviation, add the Step Attenuator Error to the Deviation from 6th Division for each setting. The difference between the maximum positive and the maximum negative Corrected Deviation values from -10 dBm to -80 dBm should not exceed 1.0 dB. The difference between the maximum positive and the maximum negative Corrected Deviation values from -10 dBm to -100 dBm should not exceed 2.0 dB.

- 10 dBm to - 80 dBm _____ dB
 - 10 dBm to - 100 dBm _____ dB

002: Change ranges to +40 dBm V to -30 dBm V and +40 dBm V to -50d BmV

PERFORMANCE TESTS

4-23. REFERENCE LEVEL ACCURACY (Cont'd)

Table 4-9. IF Gain Accuracy in LOG Mode

REFERENCE LEVEL Setting (dBm)	Step Attenuator Setting (db)	Deviation from 6 th Division (db)	Step Attenuator Error (Calibration)* (dB)	Corrected Deviation (db)
-10	0	0 (Ref.)	Ref.	0 (Ref.)
-20	10	_____	_____	_____
-30	20	_____	_____	_____
-40	30	_____	_____	_____
-50	40	_____	_____	_____
-60	50	_____	_____	_____
-70	60	_____	_____	_____
-80	70	_____	_____	_____
-90	80	_____	_____	_____
-100	90	_____	_____	_____

002: REFERENCE LEVEL (dBm V) from top to bottom: 40, 30, 20, 10, 0, -10, -20, -30, -40, -50.

*Attenuations > dial settings are positive (+). Attenuations < dial settings are negative (-). For example, 9.99 dB calibration for a 10 dB attenuator setting represents an error of -0.01 dB.

Step Accuracy in Linear Mode

- Set the spectrum analyzer Amplitude Scale switch to LIN. Set REFERENCE LEVEL control to - 10 dBm and set step attenuator to 0 dB. Readjust signal generator OUTPUT LEVEL until trace is 6 divisions above graticule baseline.
- Set the 8558B REFERENCE LEVEL control and step attenuator to settings indicated in Table 4-10. Record the Deviation from the 6th Division in Linear Mode (reference set in step 5) for each setting.
- Using Table 4-11, convert Deviation from 6th Division in Linear Mode to deviation in dB for each setting. Record dB values in Table 4-10.
- To compute the Corrected Deviation, add the Step Attenuator Error to the Deviation from the 6th Division in dB. The difference between the maximum positive and the maximum negative Corrected Deviation values from - 10 dBm to - 80 dBm should not exceed 1.0 dB. The difference between the maximum positive and the maximum negative Corrected Deviation values from - 10 dBm to - 100 dBm should not exceed 2.0 dB.

002: Change ranges to + 40 dBm V to -30 dBm V and +40 dBm V to -50 dBm V.

- 10 dBm to - 80 dBm _____ dB
 - 10 dBm to - 100 dBm _____ dB

PERFORMANCE TESTS

4-23. REFERENCE LEVEL ACCURACY(Cont'd)

Table 4-10. IF Gain Accuracy in Linear Mode

REFERENCE LEVEL Setting (dBm)	Step Attenuator Setting (db)	Deviation from 6 th Division in Linear Mode (div.)	Deviation from 6 th Division in db*	Step Attenuator Error (Calibration)** (dB)	Corrected Deviation (dB)
-10	0	0 (Ref.)	0 (Ref.)	Ref.	0 (Ref.)
-20	10	_____	_____	_____	_____
-30	20	_____	_____	_____	_____
-40	30	_____	_____	_____	_____
-50	40	_____	_____	_____	_____
-60	50	_____	_____	_____	_____
-70	60	_____	_____	_____	_____
-80	70	_____	_____	_____	_____
-90	80	_____	_____	_____	_____
-100	90	_____	_____	_____	_____

002: REFERENCE LEVEL (dBmV) from top to bottom: 40, 30, 20, 10, 0, -10, -20, -30, -40, -50.

*Use Table 4-11 to convert deviation in linear mode to deviation in dB.

**Attenuations > dial settings are positive (+). Attenuations < dial settings are negative (-).

Table 4-11. Conversion Table, Deviation in Linear Mode

POSTIVE DEVIATIONS (Above 6 th division from graticule baseline)		NEGATIVE DEVIATIONS (Below 6 th division from graticule baseline)	
Liner (Divisions)	dB	Liner (Divisions)	dB
0	0	0	0
+1	+0.14	-1	-0.15
+2	+0.28	-2	-0.29
+3	+0.42	-3	-0.45
+4	+0.56	-4	-0.60
+5	+0.70	-5	-0.76
+6	+0.82	-6	-0.92
+7	+0.96	-7	-1.08
+8	+1.09	-8	-1.24
+9	+1.21	-9	-1.41
+1.0	+1.34	-1.0	-1.58
+1.1	+1.46	-1.1	-1.76
+1.2	+1.58	-1.2	-1.94
+1.3	+1.70		
+1.4	+1.82		
+1.5	+1.94		

PERFORMANCE TESTS

4-23. REFERENCE LEVEL ACCURACY(Cont'd)

Vernier Accuracy

9. Replace 10 dB step attenuator with 1 dB step attenuator. Set spectrum analyzer as follows:

REFERENCE LEVEL.....- 10 dBm
 REFERENCE LEVEL FINE.....0
 Amplitude ScaledB/DIV
 FREQ SPAN/DIV..... 50 kHz
 RESOLUTION BW 300 kHz

10. Center the signal on the CRT and adjust signal generator OUTPUT LEVEL until trace is 6 divisions above graticule baseline. Set step attenuator and spectrum analyzer REFERENCE LEVEL FINE to settings indicated in Table 4-12. Record Deviation from 6th Division for each setting.

11. To compute Corrected Deviation, add Step Attenuator Error to Deviation from 6th Division for each setting. Corrected Deviation should not exceed + 0.5 dB or -0.5 dB for each setting.

Table 4-12. Vernier Accuracy

Step Attenuator Setting (dB)	REFERENCE LEVEL FINE Setting	Deviation From 6 th Division (dB)	Step Attenuator Error (Calibration)* (dB)	Corrected Deviation (dB)
0	0	0 (Ref.)	Ref.	0 (Ref.)
1	-1	_____	_____	_____
2	-2	_____	_____	_____
3	-3	_____	_____	_____
4	-4	_____	_____	_____
5	-5	_____	_____	_____
6	-6	_____	_____	_____
7	-7	_____	_____	_____
8	-8	_____	_____	_____
9	-9	_____	_____	_____
10	-10	_____	_____	_____
11	-11	_____	_____	_____
12	-12	_____	_____	_____

* Attenuations > dial settings are positive (+). Attenuations < dial settings are negative (-).

PERFORMANCE TESTS

4-24. DISPLAY FIDELITY

SPECIFICATION

Log Incremental Accuracy:
 ± 0.1 dB per dB from Reference Level
 Log Maximum Cumulative Error:
 < ± 1.5 dB over entire 70-dB range
 Linear Accuracy:
 ± 3% of Reference Level

DESCRIPTION

The amplitude log display amplifier is tested by connecting a DVM to the rear panel AUX A connector (vertical output) of the mainframe. The widest analyzer bandwidth possible is selected so the signal appears as a straight horizontal line on the CRT display. The DVM is used to provide good resolution when checking for ±1 dB per 10 dB step (0.1 dB/dB).

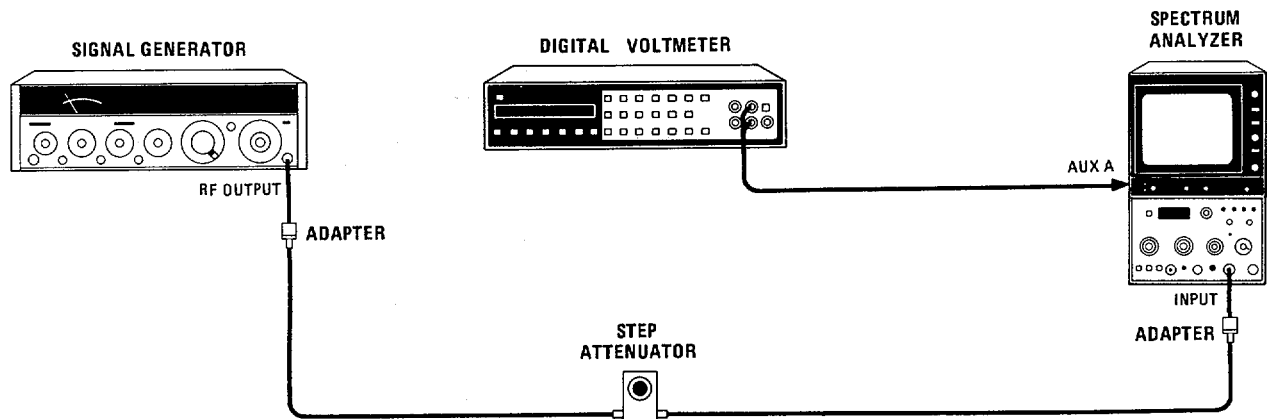

Figure 4-20. Amplitude Log Display Accuracy Test Setup

EQUIPMENT

Signal Generator	HP 8640B
Digital Voltmeter.....	HP 3455A
10 dB Step Attenuator	HP 355D Opt. H82
Adapter, Type N (m) to BNC (f) (2 required)	HP 1250-0780
Cable, BNC to Banana Plug	HP 11001A

Additional Equipment, Options 001 and 002:

Minimum Loss Adapter, 75W to 50W.....	HP 08558-60031
Adapter, BNC (m) to BNC (m), 75W.....	HP 1250-1288
Adapter, SMA (f) to SMA (f).....	HP 1250-1158
Adapter, BNC (f) to SMA (m).....	HP 1250-1200

PERFORMANCE TESTS

4-24. DISPLAY FIDELITY (Cont'd)

PROCEDURE

Log Display Accuracy

- 1. Set controls as follows:

Spectrum Analyzer

Table with 2 columns: Control Name and Setting. Includes START - CENTER (CENTER), TUNING (30 MHz), FREQ SPAN/DIV (500 kHz), RESOLUTION BW (300 kHz), INPUT ATTEN (10 dB), REFERENCE LEVEL (0 dBm), REF LEVEL FINE (0), Amplitude Scale (10 dB/DIV), SWEEP TIME/DIV (AUTO), SWEEP TRIGGER (FREE RUN), BASELINE CLIPPER (OFF), VIDEO FILTER (OFF).

Digital Voltmeter

Table with 2 columns: Control Name and Setting. Includes RANGE (100), FUNCTION (V (DC)), AUTO CAL (AUTO), TRIGGER (INTERNAL), MATH (OFF).

Signal Generator

Table with 2 columns: Control Name and Setting. Includes FREQUENCY (30 MHz), COUNTERMODE (INT), OUTPUT LEVEL (0 dBm), AM (OFF), FM (OFF).

- 2. With no signal at INPUT, measure and record the vertical output (AUX A) offset of the spectrum analyzer. _____ mV
3. Connect equipment as shown in Figure 4 20. Tune signal generator to 30 MHz and set power output for approximately 0 dBm. Set step attenuator to 0 dB.
4. Set spectrum analyzer Amplitude Scale to 10 dB/DIV and adjust TUNING control to center the signal on CRT display.
5. Set the FREQ SPAN/DIV control to zero (0) and RESOLUTION BW control to 100 kHz. Tune the signal generator frequency for maximum reading on DVM.

PERFORMANCE TESTS

4-24. DISPLAY FIDELITY(Cont'd)

6. Set the signal generator OUTPUT LEVEL so the DVM reads + 800 mV plus the offset (step 2) \pm 0.5 mV. The trace should be approximately at the top graticule line.

Table 4-13. Amplitude Log Display Accuracy

Attenuator Setting (dB)	DVM Reading (mV)	Corrected DMV Reading* (mV)	AUX A Theoretical Reading (mV)	AUX A Theoretical Reading Subtracted From Corrected DMV Reading (mV)	Difference Between Adjacent Readings (mV)
0		+800 (Ref.)	+800	0	
10	-	-	+700	-	-
20	-	-	+600	-	-
30	-	-	+500	-	-
40	-	-	+400	-	-
50	-	-	+300	-	-
60	-	-	+200	-	-
70	-	-	+100	-	-

*DVM Reading minus offset recorded in step 2.

Example (+ 5 mV offset):

Table 4-14. Sample Computations of Amplitude Log Display Accuracy

Attenuator Setting (dB)	DVM Reading (mV)	Corrected DMV Reading* (mV)	AUX A Theoretical Reading (mV)	AUX A Theoretical Reading Subtracted From Corrected DMV Reading (mV)	Difference Between Adjacent Readings (mV)
0	+805	+800	+800	0	
10	+811	+703	+700	<u>+3</u>	<u>-3</u>
20	+599	+594	+600	<u>-6</u>	<u>+9</u>
30	+497	+492	+500	<u>-8</u>	<u>+2</u>
40	+406	+401	+400	<u>+1</u>	<u>-9</u>

*DVM Reading minus offset recorded in step 2.

7. Record the DVM Reading for each 10 dB step of the step attenuator, up to 70 dB, in Table 4-13.
8. Having recorded the DVM readings for all of the attenuator settings from 0 to 70 dB, subtract the AUX A Theoretical Reading from the Corrected DVM Reading (DVM reading minus offset) in each case and record results in Table 4-13. Theoretical Reading Subtracted From Corrected DVM Reading should not exceed \pm 15 mV (\pm 1.5 dB).

PERFORMANCE TESTS

4.24. DISPLAY FIDELITY (Cont'd)

9. Subtract each converted reading (AUX A Theoretical Reading Subtracted From Corrected DVM Reading) from the previous converted reading. This subtraction must be performed algebraically. Record results in Table 4-13 (see Example).
10. The difference between adjacent readings (Table 4-13) should not exceed 10 mV (4 0.1 dB/dB).

Linear Display Accuracy

11. Replace 10 dB step attenuator with 1 dB step attenuator. Set step attenuator to 0 dB.
12. Set spectrum analyzer Amplitude Scale to LIN and RESOLUTION BW control to 1 MHz.
13. Peak the signal on the CRT display using the TUNING control. Set the signal generator OUTPUT LEVEL to place the trace at the top graticule line.
14. Set the step attenuator to 6 dB. Trace should be at 4th division above graticule baseline (center horizontal graticule line) 1.2 minor divisions.
_____ div
15. Set the step attenuator to 12 dB. Trace should be at 2nd division above graticule baseline 1.2 minor divisions.
_____ div

PERFORMANCE TESTS

4-25. CALIBRATOR ACCURACY

SPECIFICATION

Amplitude: $-30 \text{ dBm} \pm 1 \text{ dB}$.
 002: $+20 \text{ dBmV} \pm 1 \text{ dB}$.

Frequency: $280 \text{ MHz} \pm 300 \text{ MHz}$.

DESCRIPTION

The amplitude accuracy and frequency accuracy of the CAL OUTPUT signal are checked for $-30 \text{ dBm} \pm 1 \text{ dB}$ and $280 \text{ MHz} \pm 300 \text{ kHz}$, respectively.
 002: $+20 \text{ dBmV} \pm 1 \text{ dB}$.

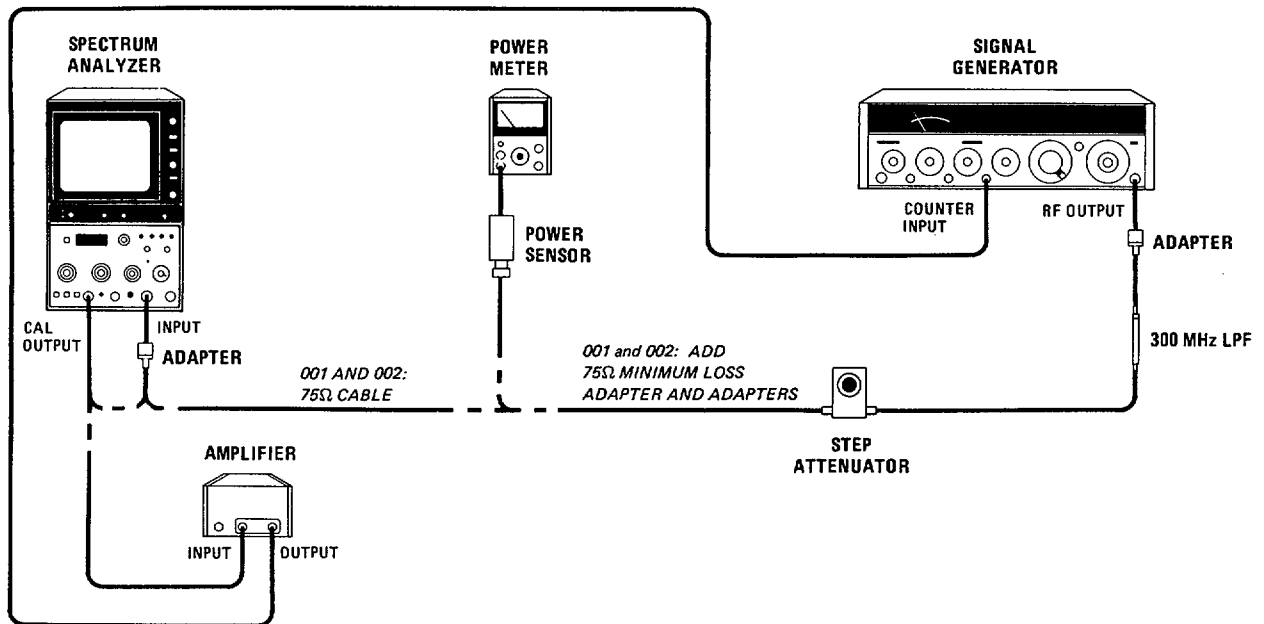

Figure 4-21. Calibrator Accuracy Test Setup

PERFORMANCE TESTS

4-25. CALIBRATOR ACCURACY (Cont'd)

EQUIPMENT

Amplifier.....	HP 8447D
Signal Generator	HP 8640B
10 dB Step Attenuator (Calibrated at 280 MHz)	HP 355D Opt. H82
Power Meter.....	HP 435B
300 MHz LPF	TELONIC TLP 300-4AB
Power Sensor.....	HP 8482A
Adapter, Type N (m) to BNC (f) (2 required)	HP 1250-6780
Adapter, Type N (f) to BNC (m)	HP 1250-0077
BNC Cable, 120 cm (48 in) (2 required).....	HP 10503A

Additional Equipment for Options 001 and 002:

Power Sensor, 750.....	HP 8483A
Adapter, GR Type 874 to BNC (m), 75W.....	General Radio 0874-9754
Adapter, GR Type 874 to N (f), 75W	General Radio 0874-9751
Minimum Loss Adapter, 75Q to 50W.....	HP 08558-60031
Adapter, BNC (m) to BNC (m)	HP 1250-0216
Adapter, SMA (f) to SMA (f).....	HP 1250-1158
Adapter, BNC(f) to SMA (m).....	HP 1250-1200
BNC Cable 30 cm (12 in), 75W	HP 11652-60012

PROCEDURE

1. Set spectrum analyzer controls as follows:

START - CENTER.....	CENTER
TUNING	280 MHz
FREQ SPAN/DIV	1 MHz
RESOLUTION BW	1 MHz
INPUT ATTEN.....	10 dB
REFERENCE LEVEL	-20 dBm
002: +30dBmV	
Amplitude Scale	10 dB/DIV
SWEEP TIME/DIV	AUTO
SWEEP TRIGGER.....	FREE RUN
BASELINE CLIPPER.....	OFF

2. Set signal generator COUNTER MODE to EXT, 0-550, and EXPAND-X10. Connect spectrum analyzer CAL OUTPUT to signal generator COUNTER INPUT connector through amplifier. Frequency counter should indicate 280 MHz ± 300 kHz.

_____ MHz

3. Set signal generator COUNTER MODE to INT and tune frequency to 280 MHz. Connect output of signal generator to calibrated step attenuator through 300 MHz low pass filter. Set signal generator OUTPUT LEVEL to 0 dBm.

PERFORMANCE TESTS

4-25. CALIBRATOR ACCURACY(Cont'd)

4. Set step attenuator to 10 dB and connect power sensor and power meter to attenuator as shown in Figure 4-21.
5. Set signal generator OUTPUT LEVEL power for a 10 dBm reading on power meter. Leave signal generator set at this level.
6. Set step attenuator to 30 dB and connect output of step attenuator to spectrum analyzer INPUT connector.
7. Set spectrum analyzer TUNING control to center signal on CRT display. Peak amplitude of reference signal should be one division down from top graticule line.
8. Set Amplitude Scale switch to 1 dB/DIV and adjust REF LEVEL FINE control so peak amplitude of reference signal is one division down from top graticule line.
9. Disconnect reference signal and connect spectrum analyzer CAL OUTPUT to the INPUT connector. Signal peak amplitude should be one division down from top graticule line ± 1 division.

- 31 dBm _____ 29 dBm

PROCEDURE FOR OPTIONS 001 and 002:

1. *Set spectrum analyzer controls as indicated above.*
 2. *Connect CAL OUTPUT to 8640B counter input connector through amplifier. Frequency counter should indicate 280 MHz ± 300 kHz. (Use EXPAND X10 COUNTER MODE, EXT 0-550.)*
 3. *Set signal generator frequency to 280 MHz. Connect output of signal generator to calibrated step attenuator and 75-ohm minimum loss adapter (approximately 5.7 dB attenuation). Set signal generator OUTPUT LEVEL to 5 dBm.*
 4. *Set the step attenuator to 0 dB. Connect minimum loss adapter through power sensor to power meter.*
 5. *Set signal generator OUTPUT LEVEL for a 10 dBm (Option 001) or -8.75 dBm (Option 002) reading on power meter. Leave the signal generator set at this level.*
 6. *Set step attenuator to 20 dB and connect -30 dBm (+20 dBm V) reference signal from signal generator through step attenuator, minimum loss adapter, and 75 ohm cable to HP 8558B INPUT 75W connector.*
 7. *With Amplitude Scale switch set to 10 dB/DIV, adjust TUNING control to center signal on CRT display. Peak amplitude of reference signal should be one division down from the top graticule line.*
-

PERFORMANCE TESTS

4-25. CALIBRATOR ACCURACY (Cont'd)

8. *Set Amplitude Scale switch to 1 dB/DIV and adjust REF LEVEL FINE control so peak amplitude of reference signal is on seventh graticule line (one division down from top).*
9. *Disconnect the reference signal and connect HP 8558B CAL OUTPUT through 75-ohm cable to INPUT 75g connector. Signal peak amplitude should be one division down from top, plus or minus one division.*

001: -31 dBm _____ 29 dBm

002: + 19 dBm V _____ 21 dBm V

Table 4-15. Performance Test Record (1 of 4)

Hewlett-Packard Company Model 8558B Spectrum Analyzer 0.1-1500 MHz Serial No. _____		Tested by: _____ Date: _____		
Paragraph Number	Test Description	Results		
		Min.	Actual	Max.
4-11	Frequency Span Accuracy			
	3. 100 MHz FREQ SPAN/DIV	-0.4 div	-	+0.4 div
	4. 50 MHz FREQ SPAN/DIV	-0.4 div	-	+0.4 div
	5. 20 MHz FREQ SPAN/DIV	-0.4 div	-	+0.4 div
	6. 10 MHz FREQ SPAN/DIV	-0.4 div	-	+0.4 div
	7. 5 MHz FREQ SPAN/DIV	-0.4 div	-	+0.4 div
	8. 2 MHz FREQ SPAN/DIV	-0.4 div	-	+0.4 div
	9. 1 MHz FREQ SPAN/DIV	-0.4 div	-	+0.4 div
	10. 500 kHz FREQ SPAN/DIV	-0.4 div	-	+0.4 div
	13. 200 kHz FREQ SPAN/DIV	-0.4 div	-	+0.4 div
	14. 100 kHz FREQ SPAN/DIV	-0.4 div	-	+0.4 div
	50 kHz FREQ SPAN/DIV	-0.4 div	-	+0.4 div
	20 kHz FREQ SPAN/DIV	-0.4 div	-	+0.4 div
	10 kHz FREQ SPAN/DIV	-0.4 div	-	+0.4 div
5 kHz FREQ SPAN/DIV	-0.4 div	-	+0.4 div	
4-12	TUNING Accuracy			
	5. 10.0 MHz	-5.2 div (8.96 MHz)	-	+5.2 div (11.04 MHz)
	6. 20.0MHz	-5.2 div (18.96 MHz)	-	+5.2 div (21.04 MHz)
	40.0 MHz	-5.2 div (38.96 MHz)	-	+5.2 div (41.04 MHz)
	60.0 MHz	-5.2 div (58.96 MHz)	-	+5.2 div (61.04 MHz)
	80.0 MHz	-5.2 div (78.96 MHz)	-	+5.2 div (81.04 MHz)
	100.0 MHz	-5.2 div (96.96 MHz)	-	+5.2 div (101.04 MHz)
	120.0 MHz	-5.2 div (118.96 MHz)	-	+5.2 div (121.04 MHz)
	140.0 MHz	-5.2 div (138.96 MHz)	-	+5.2 div (141.04 MHz)
	160.0 MHz	-5.2 div (158.96 MHz)	-	+5.2 div (161.04 MHz)
	180.0 MHz	-5.2 div (178.96 MHz)	-	+5.2 div (181.04 MHz)
	200 MHz	-5.2 div (194.8 MHz)	-	+5.2 div (205.2 MHz)

Table 4-15. Performance Test Record (2 of 4)

Paragraph Number	Test Description	Results		
		Min.	Actual	Max.
4-12	TUNING Accuracy (Cont'd)			
	400 MHz	-5.2 div (394.8 MHz)	-	+5.2 div (405.2 MHz)
	600 MHz	-5.2 div (594.8 MHz)	-	+5.2 div (605.2 MHz)
	800 MHz	-5.2 div (794.8 MHz)	-	+5.2 div (805.2 MHz)
	1000 MHz	-5.2 div (994.8 MHz)	-	+5.2 div (1005.2 MHz)
	1200 MHz	-5.2 div (1194.8 MHz)	-	+5.2 div (1205.2 MHz)
	1400 MHz	-5.2 div (1394.8 MHz)	-	+5.2 div (1405.2 MHz)
	1500 MHz	-5.2 div (1494.8 MHz)	-	+5.2 div (1505.2 MHz)
4-13	Residual FM 6. Peak-to-Peak Variation of Trace		-	1.0 div (1 kHz/0.1 sec)
4-14	Noise Sidebands 6. Noise Sidebands		-	6.5 div down (-65 dB)
4-15	Resolution Bandwidth Accuracy			
	7. 3 MHz Resolution BW	2.40 MHz	-	3.60 MHz
	8. 1 MHz Resolution BW	800 kHz	-	1.20 MHz
	9. 300 kHz Resolution BW	240 kHz	-	360 kHz
	10. 100 kHz Resolution BW	80 kHz	-	120 kHz
	17. 30 kHz Resolution BW	24 kHz	-	36 kHz
	18. 10 kHz Resolution BW	8 kHz	-	12 kHz
4-16	19. 3 kHz Resolution BW	2.4 kHz	-	3.6 kHz
	20. 1 kHz Resolution BW	0.8 kHz	-	1.2 kHz
	Resolution Bandwidth Selectivity			
	24. 3 MHz Resolution BW Selectivity		-	15:1
	1 MHz Resolution BW Selectivity		-	15:1
	300 kHz Resolution BW Selectivity		-	15:1
	100 kHz Resolution BW Selectivity		-	15:1
	30 kHz Resolution BW Selectivity		-	15:1
10 kHz Resolution BW Selectivity		-	15:1	
3 kHz Resolution BW Selectivity		-	15:1	
1 kHz Resolution BW Selectivity		-	15:1	

Table 4-15. Performance Test Record (3 of 4)

Paragraph Number	Test Description	Results		
		Min.	Actual	Max.
4-17	Average Noise Level			
	2 Average Noise Level 1 MHz to 1000 MHz		-	-107 dBm
	3 Average Noise Level 500 MHz to 1500 MHz		-	-107 dBm
	5 Average Noise Level 1 MHz to 11 MHz		-	-107 dBm
	001: Max. is -100 dBm			
	002: Max. is -53 dBm V			
4-18	Spurious Responses			
	9. Harmonic Distortion			
	2nd Harmonic	-70 dB	-	
	3rd Harmonic	-70 dB	-	
	18. Third Order Intermodulation Distortion, 30 MHz input signals	-70 dB	-	
	20. Second Order Intermodulation Distortion, 30 MHz input signals ($f_1 + f_2$)	-70 dB	-	
	22. Second Order Intermodulation Distortion, 30 MHz input signals ($f_1 + f_2$)	-70 dB	-	
	27. Third Order Intermodulation Distortion, 4 MHz input signals	-60 dB	-	
	29. Second Order Intermodulation Distortion, 4 MHz input signals ($f_1 + f_2$)	-60 dB	-	
	30. Second Order Intermodulation Distortion, 4 MHz input signals ($f_1 + f_2$)	-60 dB	-	
4-19	Residual Responses			
	11. Residual Responses 1 MHz to 1000 MHz		-	-100 dBm
	17. Residual Responses 500 MHz to 1500 MHz		-	-100 dBm
	001: Max. is <-95 dBm			
	002: Max. is <-45 dBm V			
4-20	Frequency Response			
	17. Frequency Response		-	2.0 dB
4-21	Bandwidth Switching (Amplitude Variation)			
	6. 3 MHz to 300 kHz (overall variation)	-0.5 dB	-	+0.5 dB
	3 MHz to 1 kHz (overall variation)	-1.0 dB	-	+1.0 dB
4-22	Input Attenuator Accuracy			
	4. Error Between Adjacent Settings		-	±0.5 dB (1.0 dB)
	5. Error Over Full 70 dB Range		-	±1.0 dB (2.0 dB)

Table 4-15. Performance Test Record (4 of 4)

Paragraph Number	Test Description	Results		
		Min.	Actual	Max.
4-23	Reference Level Accuracy			
	4. Step Accuracy in Log			
	-10 dBm to -80 dBm			±0.5 dB
	-10 dBm to -100 dBm			(1.0 dB)
	002: +40 dBm V to -30 dBm V			±1.0 dB
	+40 dBm V to -50 dBm V			(2.0 dB)
	8. Step Accuracy in LIN			
	-10 dBm to 80 dBm			±0.5 dB
	-10 dBm to -100 dBm			(1.0 dB)
	002: +40 dBm V to -30 dBm V			±1.0 dB
	+40 dBm V to -50 dBm V			(2.0 dB)
	11. Vernier Accuracy			
	REF LEVEL FINE:			
-1	-0.5 dB		+0.5 dB	
-2	-0.5 dB		+0.5 dB	
-3	-0.5 dB		+0.5 dB	
-4	-0.5 dB		+0.5 dB	
-5	-0.5 dB		+0.5 dB	
-6	-0.5 dB		+0.5 dB	
-7	-0.5 dB		+0.5 dB	
-8	-0.5 dB		+0.5 dB	
-9	-0.5 dB		+0.5 dB	
-10	-0.5 dB		+0.5 dB	
-11	-0.5 dB		+0.5 dB	
-12	-0.5 dB		+0.5 dB	
4-24	Display Fidelity			
	Log Display Accuracy			
	8. Maximum Error Over Full 70 dB Display Range			±1.5 dB
	10. Error Between Adjacent Readings			(±15 mV)
	Linear Display Accuracy			±1.0 dB
14. Error at 4th division	3.76 div		(±10 mV)	
15. Error at 2nd division	1.76 div			
4-25	Calibrator Accuracy			
	2. CAL OUTPUT Frequency	279.7 MHz		280.3 MHz
	9. CAL OUTPUT Amplitude	-31 dBm		-29 dBm
	002: Min. is + 19 dBm V, Max. is +21 dBm V			

THIS PAGE MISSING NOT AVAILABLE FOR DIGITIZATION.

**PAGES
4-63 through 4-69**

SECTION V. ADJUSTMENTS

5-1. INTRODUCTION

5-2. The adjustments in this section are required to optimize spectrum analyzer performance after repair. Table 5-1 lists adjustable components by adjustment name, reference designation, adjustment paragraph, and description.

5-3. Data taken during adjustment should be recorded in the spaces provided. Comparison of initial data with data taken during periodic adjustments is useful for preventive maintenance and troubleshooting.

WARNING

The adjustments in this section require the spectrum analyzer to be removed from the display mainframe and connected through an extender cable assembly. Be very careful; the energy at some points in the instrument might, if contacted, cause personal injury. The adjustments in this section should be performed only by a skilled person who knows the hazard involved.

NOTE

Before performing any adjustments, allow 1 hour warmup time.

5-4. EQUIPMENT REQUIRED

5-5. The table of Recommended Test Equipment in Section I lists the test equipment and test accessories required in the adjustment procedures. In addition, the table lists the required minimum specifications and suggested manufacturers' model numbers.

5-6. Required service accessories, with part numbers, are illustrated in Section I.

5-7. Adjustment Tools

5-8. For adjustments requiring a non-metallic tuning tool, use fiber tuning tool, HP Part Number 8170-0033. Never try to force an adjustment control in the analyzer. This is especially critical when tuning slug-tuned inductors and variable capacitors.

5-9. Extender Cable Installation

WARNING

Disconnect mainframe line cord before installing extender cable assembly.

5-10. Pull out the lock knob and slide the spectrum analyzer out of the display mainframe. If side stops are installed, refer to Section II for removal.

5-11. Carefully slide the extender cable assembly, HP part number 5060-0303, into the display mainframe, aligning the metal guide plate with the slotted side rails of the mainframe. Firmly seat the extender cable assembly to ensure good contact.

5-12. Connect the opposite end of the cable to the spectrum analyzer. The plug is keyed so it will go on correctly and will not make contact upside down. Remove the orange and the yellow leads from pins 3 and 4 on the A15 board at the rear of the spectrum analyzer. Connect the corresponding leads from the extender cable assembly to these pins by means of the insulated alligator clips.

5-13. RELATED ADJUSTMENTS

5-14. These adjustments should be performed whenever troubleshooting information in Section VIII indicates that an adjustable circuit is not operating properly. Perform the adjustments after repair or replacement of the circuit. The troubleshooting procedures and Table 5-1 specify the required adjustments.

5-15. FACTORY-SELECTED COMPONENTS

5-16. Table 5-2 provides a list of factory-selected components by reference designation, selection procedure paragraph number, range of values, and basis

of selection. Factory-selected components are designated by an asterisk (*) on the schematic diagrams in Section VIII and in the table of Replaceable Parts, Section VI. Part numbers for standard-value components can be found in Table 5-3.

Table 5-1. Adjustable Components (1 of 4)

Adjustment Name	Reference Designator	Adjustment Paragraph	Description
REF	A1A2R3	5-28	Adjusts DPM reference voltage and adjusts frequency for correct FREQUENCY MHz readout at 1500 MHz.
2nd MIXER MATCH	A5L2	5-17	Adjust for optimum match between second converter output and second IF input.
Z1, Z2, Z3	A5Z1 A5Z3	5-17	Adjust the bandpass of the 2050 MHz bandpass filter.
2nd LO FREQUENCY	A5Z4	5-17	Adjusts second LO frequency to 1748.60 MHz.
3.55 GHZ	A7R1	5-28	Coarse adjustment of YIG upper frequency limit, 3.55 GHz.
3.55 FINE	A7R2	5-28	Fine adjustment of YIG upper frequency limit, 3.55 GHz.
2.0 GHZ REF V	A7R3 A7R4	5-28 5-28	Adjusts YIG lower frequency limit, 2.05 GHz Adjusts reference voltage to 6.0 volts and is fine adjustment of YIG lower frequency limit, 2.05 GHz.
+14.5V	A7R5	5-28	Adjusts 14.5 volt supply to +14.5 volts.
FM	A7R6	5-28	Adjusts frequency span accuracy for frequency spans <1 MHz per division.
GAIN	A7R7	5-28	Adjusts frequency for correct DPM frequency readout at 190.0 MHz.
RNG	A7R8	5-28	Adjusts frequency control circuit for proper DPM ranging.
OFS	A7R72	5-28	Adjusts frequency for correct FREQUENCY MHZ readout at 200 MHz.
2 ms	A8R13	5-27	Adjusts sweep ramp to calibrate 2 ms per division sweep time.
1 ms	A8R10	5-27	Adjusts sweep ramp to calibrate 1 ms per division sweep time.
+10V	A8R7	5-27	Adjusts +10 volt supply. This adjustment must be performed while spectrum analyzer is still cold, during first five minutes after turn on.
XTL	A8R72	5-21 5-22	Adjusts IF bandwidth between 3 dB points for RESOLUTION BW setting of 3 kHz.
LC	A8R85	5-21	Adjusts IF bandwidth between 3 dB points for RESOLUTION BW setting of 1 MHz.
LO FREQ	A9L4	5-18	Adjusts third converter 280 MHz crystal-controlled LO for maximum output.

Table 5-1. Adjustable Components (2 of 4)

Adjustment Name	Reference Designator	Adjustment Paragraph	Description
SLOPE COMP	A9R1	5-19	Compensates for frequency response of input mixer, allowing flatness of less than 2 dB.
3rd LO PWR	A9R5	5-18	Adjusts CAL OUTPUT signal for -30 dBm power level. <i>002: +20 dBm V.</i>
C 1, C2, C3	A10C1 A10C3	5-20	Adjust the bandpass of the Second IF assembly Bandpass Filter (301.4 MHz).
2nd IF TUNING	A10L2	5-20	Peaks second IF bandpass amplifier. Has very little effect on signal.
SYM	A11C15	5-21	Adjust symmetry of first stage of crystal bandwidth filter.
LC CTR	A11C23	5-21	Adjusts centering of first stage of LC bandwidth filter.
CTR	A11C25	5-21	Adjusts centering of first stage of crystal bandwidth filter.
SYM	A11C38	5-21	Adjusts symmetry of second stage of crystal bandwidth filter.
LC CTR	A11C45	5-21	Adjusts centering of second stage of LC bandwidth filter.
CTR	A11C54	5-21	Adjusts centering of second stage of crystal bandwidth filter.
C73	A11C73	5-21	Compensates for capacitance of CR3.
C74	A11C74	5-21	Compensates for capacitance of CR11.
LC	A11R26	5-21	Adjusts feedback in LC circuit of bandpass filter.
XTL	A11R31	5-21	Adjusts feedback in crystal circuit of bandpass filter.
40 dB	A12R1	5-24	Adjust 40 dB step gain.
10 dB	A12R3	5-24	Adjusts 10 dB step gain.
GAIN	A12R4	5-23	Adjusts overall gain of Step Gain assembly.
0 dB	A12R5	5-24	Adjusts to calibrate 0 dB position of REF LEVEL FINE control.

Table 5-1. Adjustable Components (3 of 4)

Adjustment Name	Reference Designator	Adjustment Paragraph	Description
-12 dB	A12R6	5-24	Adjusts to calibrate -12 dB position of REF LEVEL FINE control.
+19.5V	A12R7	5-25	Adjusts +19.5 volt supply.
SYM	A13C15	5-21	Adjusts symmetry of first stage of crystal bandwidth filter.
LC CTR	A13C23	5-21	Adjusts centering of first stage of LC bandwidth filter.
CTR	A13C25	5-21	Adjusts centering of first stage of crystal bandwidth filter.
SYM	A13C38	5-21	Adjusts symmetry of second stage of crystal bandwidth filter.
LC CTR	A13C45	5-21	Adjusts centering of second stage of LC bandwidth filter.
CTR	A13C54	5-21	Adjusts centering of second stage of crystal bandwidth filter.
C73	A13C73	5-21	Compensate for capacitance of CR3.
C74	A13C74	5-21	Compensates for capacitance of CR11 .
LC	A13R26	5-21	Adjusts feedback in LC circuit of bandpass filter.
XTL	A13R31	5-21	Adjusts feedback in crystal circuit of bandpass filter.
OFFSET	A14R10	5-26	Adjusts -8V temperature compensated supply.
TC	A14R21		Adjusts gain of +1V supply to provide temperature compensation for log mode temperature controlled variable gain amplifier. (Factory adjustable only.)
SLOPE	A14R23	5-26	Adjusts gain of log mode temperature controlled gain amplifier.
G6	A14R27	5-26	Adjusts combined gain of 2nd and 3rd stages in linear mode.
G5	A14R30	5-26	Adjusts gain of 4th stage in linear mode.
G4	A14R33	5-26	Adjusts gain of 5th stage in linear mode.

Table 5-1. Adjustable Components (4 of 4)

Adjustment Name	Reference Designator	Adjustment Paragraph	Description
LIN	A14R34	5-26	Adjusts combined gain of 6th and 7th stages in linear mode.
-10 dB	A14R39	5-26	Adjusts shape of log fidelity curve at -10 dB.
-30 dB	A14R69	5-26	Adjusts shape of log fidelity curve at -30 dB.
1 VT	A14R88		Adjusts voltage at A14TP1 for approximately +1V. (Factory adjustable only.)
LOG GAIN	A14R121	5-26	Adjusts dc offset circuitry at output of A14 Log Amplifier Assembly for 10 dB steps in log mode.
1 dB OFFSET	A15R1	5-29	Adjusts for equal amplitude displayed at full screen in 10 dB/DIV and 1 dB/DIV for a given input.

Table 5-2. Factory Selected Components in Alpha-Numerical Order

Reference Designator	Selection Procedure Paragraph Number	Basis of Selection
A8R30		Selected to set start of sweep ramp to -5.000V \pm 30 mV.
A8R35		Selected to set high end of sweep ramp to +5V.
A8R74		Selected to optimize 1 kHz bandwidth.
A8R76		Selected to optimize 3 kHz bandwidth.
A8R78	5-22	Selected to optimize 10 kHz bandwidth.
A9R89	5-22	Selected to optimize 300 kHz bandwidth.
A8R92		Selected to optimize 1 MHz bandwidth.
A8R95	5-22	Selected to optimize 3 MHz bandwidth.
A8R105		Selected for OV at A8TP8 with START CENTER switch in START, 100 MHz/DIV, single scan mode (no sweep).
A8R125		Selected for optimum automatic sweep time with VIDEO FILTER on (but not in detent).
A9R4	5-18	Selected for proper Third Converter LO power.
A9R9		Selected for proper CAL OUTPUT power.
A9R12		Selected for proper gain of Third Converter.
A9R14		Selected for proper REF LEVEL CAL range.
A11C20		Selected to shift adjustment range of A11C23.
A11C44		Selected to shift adjustment range of A11C45.
A11R23	5-22	Selected to give correct IF bandwidth for RESOLUTION BW of 30 kHz.
A11R43	5-22	Selected to give correct IF bandwidth for RESOLUTION BW of 100 kHz.
A11R48	5-22	Selected to give correct IF bandwidth for RESOLUTION BW of 30 kHz.
A11R56		Selected to equalize feedback between LC stages (not field selectable).
A13C20		Selected to shift adjustment range of A13C23.
A13C44		Selected to shift adjustment range of A13C45.
A13R19	5-22	Selected to give correct IF bandwidth for RESOLUTION BW of 100 kHz.
A13R23	5-22	Selected to give correct IF bandwidth for RESOLUTION BW of 30 kHz.
A13R43	5-22	Selected to give correct IF bandwidth for RESOLUTION BW of 100 kHz.
A13R48	5-22	Selected to give correct IF bandwidth for RESOLUTION BW of 30 kHz.
A13R56		Selected to equalize feedback between LC stages (not field selectable).
A14R93		Selected to shift adjustment range of A14R34.
A14R101		Selected to shift adjustment range of A14R34.
A14R107		Selected to shift adjustment range of A14R23.
A15R26		Selected to provide increased range adjustment for 1 dB offset circuit.
A17R1		Selected for proper voltage offset of A17Q1 and A17Q2 to ensure initial turn-on of oscillator.

Table 5-3. HP Part Numbers of Standard Value Replacement Components (1 of 3)

CAPACITORS							
<p>RANGE: 1 to 24 pF TYPE: Tubular TOLERANCE: 1 to 9.1 pF = ±.25 pF 10 to 24 pF = ±5%</p>				<p>RANGE: 27 to 680 pF TYPE: Dipped Mica TOLERANCE: ±5%</p>			
Value (pF)	HP Part Number	C D	Value (pF)	HP Part Number	C D		
1.0	0160-2236	8	27	0160-2306	3		
1.2	0160-2237	9	30	0160-2199	2		
1.5	0150-0091	8	33	0160-2150	5		
1.8	0160-2239	1	36	0160-2308	5		
2.0	0160-2240	4					
			43	0160-2200	6		
2.2	0160-2241	5	47	0160-2307	4		
2.4	0160-2242	6	51	0160-2201	7		
2.7	0160-2243	7	56	0140-0191	8		
3.0	0160-2244	8	62	0140-0205	5		
3.3	0150-0059	8					
			68	0140-0192	9		
3.6	0160-2246	0	75	0160-2202	8		
3.9	0160-2247	1	82	0140-0193	0		
4.3	0160-2248	2	91	0160-2203	9		
4.7	0160-2249	3	100	0160-2204	0		
5.1	0160-2250	6	110	0140-0194	1		
			120	0160-2205	1		
5.6	0160-2251	7	130	0140-0195	2		
6.2	0160-2252	8	150	0140-0196	3		
6.8	0160-2253	9	160	0160-2206	2		
7.5	0160-2254	0					
8.2	0160-2255	1	180	0140-0197	4		
			200	0140-0198	5		
9.1	0160-2256	2	220	0160-0134	1		
10.0	0160-2257	3	240	0140-0199	6		
11.0	0160-2258	4					
12.0	0160-2259	5					
13.0	0160-2260	8	330	0160-2208	4		
			360	0160-2209	5		
15.0	0160-2261	9	390	0140-0200	0		
16.0	0160-2262	0	430	0160-0939	4		
18.0	0160-2263	1					
20.0	0160-2264	2	470	0160-3533	0		
22.0	0160-2265	3	510	0160-3534	1		
			560	0160-3535	2		
24.0	0160-2266	4	620	0160-3536	3		
			680	0160-3537	4		

Table 5-3. HP Part Numbers of Standard Value Replacement Components (2 of 3)

RESISTORS

RANGE: 10 to 464 K Ohms
 TYPE: Fixed-Film
 WATTAGE: .125 at 125° C
 TOLERANCE: ±1.0%

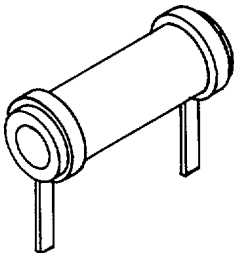
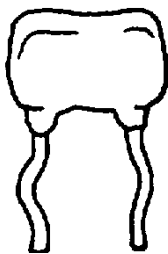

Value (W)	HP Part Number	C D	Value (W)	HP Part Number	C D	Value (W)	HP Part Number	C D
10.0	0757-0346	2	464	0698-0082	7	21.5K	0757-0199	3
11.0	0757-0378	0	511	0757-0416	7	23.7K	0698-3158	4
12.1	0757-0379	1	562	0757-0417	8	26.1K	0698-3159	5
13.3	0698-3427	0	619	0757-0418	9	28.7K	0698-3449	6
14.7	0698-3428	1	681	0757-0419	0	31.6K	0698-3160	8
16.2	0757-0382	6	750	0757-0420	3	34.8K	0757-0123	3
17.8	0757-0294	9	825	0757-0421	4	38.3K	0698-3161	9
19.6	0698-3429	2	909	0757-0422	5	42.2K	0698-3450	9
21.5	0698-3430	5	1.0K	0757-0280	3	46.4K	0698-3162	0
23.7	0698-3431	6	1.1K	0757-0424	7	51.1K	0757-0458	7
26.1	0698-3432	7	1.21K	0757-0274	5	56.2K	0757-0459	8
28.7	0698-3433	8	1.33K	0757-0317	7	61.9K	0757-0460	1
31.6	0757-0180	2	1.47K	0757-1094	9	68.1K	0757-0461	2
34.8	0698-3434	9	1.62K	0757-0428	1	75.0K	0757-0462	3
38.3	0698-3435	0	1.78K	0757-0278	9	82.5K	0757-0463	4
42.2	0757-0316	6	1.96K	0698-0083	8	90.9K	0757-0464	5
46.4	0698-4037	0	2.15K	0698-0084	9	100K	0757-0465	6
51.1	0757-0394	0	2.37K	0698-3150	6	110K	0757-0466	7
56.2	0757-0395	1	2.61K	0698-0085	0	121K	0757-0467	8
61.9	0757-0276	7	2.87K	0698-3151	7	133K	0698-3451	0
68.1	0757-0397	3	3.16K	0757-0279	0	147K	0698-3452	1
75.0	0757-0398	4	3.48K	0698-3152	8	162K	0757-0470	3
82.5	0757-0399	5	3.83K	0698-3153	9	178K	0698-3243	8
90.9	0757-0400	9	4.22K	0698-3154	0	196K	0698-3453	2
100	0757-0401	0	4.64K	0698-3155	1	215K	0698-3454	3
110	0757-0402	1	5.11K	0757-0438	3	237K	0698-3266	5
121	0757-0403	2	5.62K	0757-0200	7	261K	0698-3455	4
133	0698-3437	2	6.19K	0757-0290	5	287K	0698-3456	5
147	0698-3438	3	6.81K	0757-0439	4	316K	0698-3457	6
162	0757-0405	4	7.50K	0757-0440	7	348K	0698-3458	7
178	0698-3439	4	8.25K	0757-0441	8	383K	0698-3459	8
196	0698-3440	7	9.09K	0757-0288	1	422K	0698-3460	1
215	0698-3441	8	10.0K	0757-0442	9	464K	0698-3260	9
237	0698-3442	9	11.0K	0757-0443	0			
261	0698-3132	4	12.1K	0757-0444	1			
287	0698-3443	0	13.3K	0757-0289	2			
316	0698-3444	1	14.7K	0698-3156	2			
348	0698-3445	2	16.2K	0757-0447	4			
383	0698-3446	3	17.8K	0698-3136	8			
422	0698-3447	4	19.6K	0698-3157	3			

Table 5-3. HP Part Numbers of Standard Value Replacement Components (3 of 3)

RESISTORS

RANGE: 10 to 1.47M Ohms
 TYPE: Fixed-Film
 WATTAGE: .5 at 125°C
 TOLERANCE: ±1%



Value (W)	HP Part Number	C D	Value (W)	HP Part Number	C D	Value (W)	HP Part Number	C D	Value (W)	HP Part Number	C D
10.0	0757-0984	4	215	0698-3401	0	4.64K	0698-3348	4	110K	0757-0859	2
11.0	0575-0985	5	237	0698-3102	8	5.11K	0757-0833	2	121K	0757-0860	5
12.1	0757-0986	6	261	0757-1090	5	5.62K	0757-0834	3	133K	0757-0310	0
13.3	0757-0001	6	287	0757-1092	7	6.19K	0757-0196	0	147K	0698-3175	5
14.7	0698-3388	2	316	0698-3402	1	6.81K	0757-0835	4	162K	0757-0130	2
16.2	0757-0989	9	348	0698-3403	2	7.50K	0757-0836	5	178K	0757-0129	9
17.8	0698-3389	3	383	0698-3404	3	8.25K	0757-0837	6	196K	0757-0063	0
19.6	0698-3390	6	422	0698-3405	4	9.09K	0757-0838	7	215K	0757-0127	7
21.5	0698-3391	7	464	0698-0090	7	10.0K	0757-0839	8	237K	0698-3424	7
23.7	0698-3392	8	511	0757-0814	9	12.1K	0757-0841	2	261K	0757-0064	1
26.1	0757-0003	8	562	0757-0815	0	13.3K	0698-3413	4	287K	0757-0154	0
28.7	0698-3393	9	619	0757-0158	4	14.7K	0698-3414	5	316K	0698-3425	8
31.6	0698-3394	0	681	0757-0816	1	16.2K	0757-0844	5	348K	0757-0195	9
34.8	0698-3395	1	750	0757-0817	2	17.8K	0698-0025	8	383K	0757-0133	5
38.3	0698-3396	2	825	0757-0818	3	19.6K	0698-3415	6	422K	0757-0134	6
42.2	0698-3397	3	909	0757-0819	4	21.5K	0698-3416	7	464K	0698-3426	9
46.4	0698-3398	4	1.00K	0757-0159	5	23.7K	0698-3417	8	511K	0757-0135	7
51.1	0757-1000	7	1.10K	0757-0820	7	26.1K	0698-3418	9	562K	0757-0868	3
56.2	0757-1001	8	1.21K	0757-0821	8	28.7K	0698-3103	9	619K	0757-0136	8
61.9	0757-1002	9	1.33K	0698-3406	5	31.6K	0698-3419	0	681K	0757-0869	4
68.1	0757-0794	4	1.47K	0757-1078	9	34.8K	0698-3420	3	750K	0757-0137	9
75.0	0757-0795	5	1.62K	0757-0873	0	38.3K	0698-3421	4	825K	0757-0870	7
82.5	0757-0796	6	1.78K	0698-0089	4	42.2K	0698-3422	5	909K	0757-0138	0
90.0	0757-0797	7	1.96K	0698-3407	6	46.4K	0698-3423	6	1M	0757-0059	4
100	0757-0198	2	2.15K	0698-3408	7	51.1K	0757-0853	6	1.M	0757-0139	1
110	0757-0798	8	2.37K	0698-3409	8	56.2K	0757-0854	7	1.21M	0757-0871	8
121	0757-0799	9	2.61K	0698-0024	7	61.9K	0757-0309	7	1.33M	0757-0194	8
133	0698-3399	5	2.87K	0698-3101	7	68.1K	0757-0855	8	1.47M	0698-3464	5
147	0698-3400	9	3.16K	0698-3410	1	75.0K	0757-0856	9			
162	0757-0802	5	3.48K	0698-3411	2	82.5K	0757-0857	0			
178	0698-3334	8	3.83K	0698-3412	3	90.9K	0757-0858	1			
196	0757-1060	9	4.22K	0698-3346	2	100K	0757-0367	7			

Table 5-4. Related Adjustments

Assembly Charged or Repaired		Perform the Following Related Adjustments	Paragraph Number
A1	Digital Panel Meter	A1A2R3	5-28
A2	Front Switch	A12RS, A12R6	5-24
A3	Input Attenuator	No related adjustments	
A4	First Converter	A9R1	5-19
AS	Second Converter	A5Z1, A5Z2, A5Z3, A5Z4, A5L2	5-17
A6	YIG Oscillator	A1A2R3, A7R1, A7R2, A7R3, A7R4, A7R6, A7R7, A7R8, A7R72	5-28
A7	Frequency Control	A5Z4 A1A2R3, A7R1, A7R2, A7R3, A7R4, A7R5, A7R6, A7R7, A7R72	5-17 5-28
A8	Sweep Generator	A8R2, A8R10, A8R13, A8R72, A8R85	5-22, 5-27
A9	Third Converter	A9L4, A9R5, A9R1	5-18, 5-19
A10	Second IF	A10C1, A10C2, A10C3, A10L2	5-20
A11, A13*	Bandwidth Filters	A11C15, A11C23, A11C25, A11C38, A11C45, A11C54, A11C73, A11C74, A13C15, A13C23, A13C25, A13C38, A13C45, A13C54, A13C73, A13C74, A8R72, A8R85	5-21, 5-22
A12	Step Gain	A12R1, A12R2, A12R3, A12R4, A12R5, A12R6, A12R7	5-23 - 5-25
A14	Log Amplifier	A14R23, A14R27, A14R30, A14R33, A14R34, A14R39, A14R69, A14R121	5-26 5-29
A15	Vertical Driver and Blanking	A15R1	5-29
A16	Motherboard	No related adjustments	
A17	Inverter	No related adjustments	

*A11 and A13 bandwidth filter assemblies contain a matched set of crystals. These two assemblies must be treated as a matched pair when replacement is necessary.

ADJUSTMENTS

5-17. SECOND CONVERTER LO AND BANDPASS ADJUSTMENTS

REFERENCE

A5 Schematic

DESCRIPTION

The second converter is adjusted for 1748.60 MHz and the bandpass filter is adjusted for a 2050 MHz Bandpass.

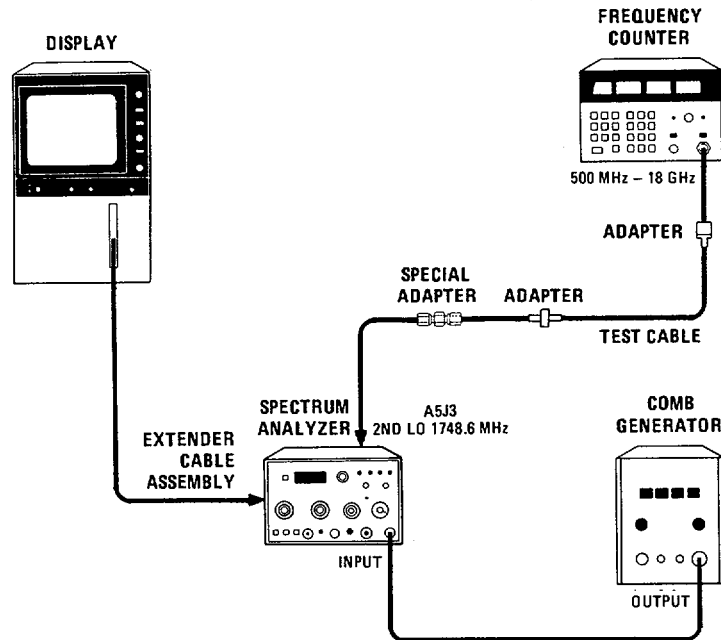

Figure 5-1. Second Converter LO and Bandpass Adjustment Test Setup

EQUIPMENT

Frequency Counter.....	HP 5342A
Comb Generator	HP 8406A
Test Cable, SMC (f) to BNC (m).....	HP 11592-60001
Adapter, SMC (m) to SMC (m).....	HP 1250-0827
Adapter, Type N (m) to BNC (f).....	HP 1250-0780
Special Adapter.....	See Figure 5-2
BNC Cable 120 cm (48 in)	HP 10503A
Extender Cable Assembly	HP 5060-0303

Additional Equipment, Options 001 and 002:

Minimum Loss Adapter, 75W to 50W.....	HP 08558-60031
Adapter, BNC (m) to BNC (m), 75W	HP 1250-1288
Adapter, SMA (f) to SMA (f)	HP 1250-1158
Adapter, BNC(f) to SMA (m).....	HP 1250-1200

ADJUSTMENTS

5-17. SECOND CONVERTER LO AND BANDPASS ADJUSTMENTS (Cont'd)

NOTE

The special adapter in Figure 5-1 is made from a SMC (f) to SMC (f) adapter, HP Part No. 1250-1113. The nuts must be soldered to the body of the subminiature RF adapter so they will both turn with the body. Be sure to space the nuts properly before soldering (see Figure 5-2).

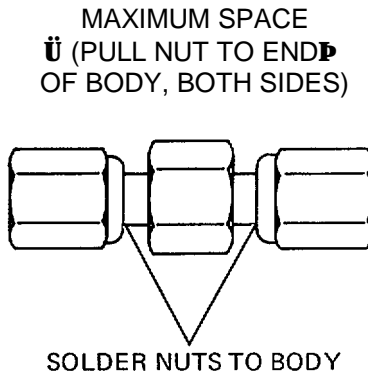

Figure 5-2. Special Adapter Used in Second Converter LO and Bandpass Test Setup

PROCEDURE

1. Set equipment as follows:

Spectrum Analyzer

START - CENTER CENTER
 TUNING 300 MHz
 FREQ SPAN/DIV 100 MHz
 RESOLUTION BW 1 MHz (optimum)
 INPUT ATTEN 0 dB
 REFERENCE LEVEL -30 dBm
 002: +20dBmV
 Amplitude Scale 10 dB/DIV
 SWEEP TIME/DIV AUTO
 SWEEP TRIGGER FREE RUN

Frequency Counter

10 Hz-500 MHz/500 MHz- 18 GHz 500 MHz- 18 GHz
 SAMPLE RATE Full counterclockwise

Comb Generator

COMB FREQUENCY 100MC
 INTERPOLATION AMPLITUDE OFF

ADJUSTMENTS

5-17. SECOND CONVERTER LO AND BANDPASS ADJUSTMENTS (Cont'd)

2. Connect equipment as shown in Figure 5-1 and switch display mainframe power ON. Connect counter to A5J3 at the top of A5 Converter Assembly. Connect comb generator to HP 8558B INPUT.
 3. Adjust second LO FREQUENCY adjustment A5Z4 for 1748.60 40.2 MHz. Use Allen wrench through center of drilled-out 5/16-inch nut driver to enable nut to be tightened without shifting frequency.
 4. Set comb generator for 100 MHz comb.
 5. Center a 100 MHz comb tooth using 8558B TUNING control. Turn FREQ SPAN/DIV control to 2 MHz and uncoupled RESOLUTION BW control to 300 kHz, keeping comb tooth centered on display.
 6. Loosen lock nut on A5Z1 and A5Z2. Carefully turn tuning screws clockwise until they bottom on cavity.
 7. Turn A5Z1 and A5Z2 one turn counterclockwise and lightly tighten lock nuts.
 8. Loosen lock nut on A5Z3, and adjust A5Z3 for peak signal on display. Make final adjustment with Amplitude Scale switch in LIN position. It might be necessary to increase gain to see signal in linear mode. Leave in LIN position.
 9. Adjust A5Z1 for peak signal on display. Reduce REFERENCE LEVEL as necessary to keep signal on display. Repeat A5Z1 and A5Z3 adjustments for maximum signal on display.
 10. Adjust A5Z2 for maximum signal on display. Reduce REFERENCE LEVEL as necessary to keep signal on display.
 11. Carefully tighten lock nuts on A5Z1, A5Z2, and A5Z3 so that signal does not change on display.
 12. Adjust A5L2 2nd MIXER MATCH adjustment for maximum signal.
 13. Check second LO frequency. If frequency error is greater than 4i0.5 MHz, repeat step 3.
-

ADJUSTMENTS

5-18. THIRD CONVERTER LO AND CAL OUTPUT ADJUSTMENT

REFERENCE

A9 Schematic

DESCRIPTION

The third converter LO frequency is adjusted for maximum output, and power is adjusted for -30 dBm \pm 1.0 dB CAL OUTPUT. The third LO frequency is checked for 280 MHz \pm 300 kHz.

002: +20 dBmV \pm 1.0dB

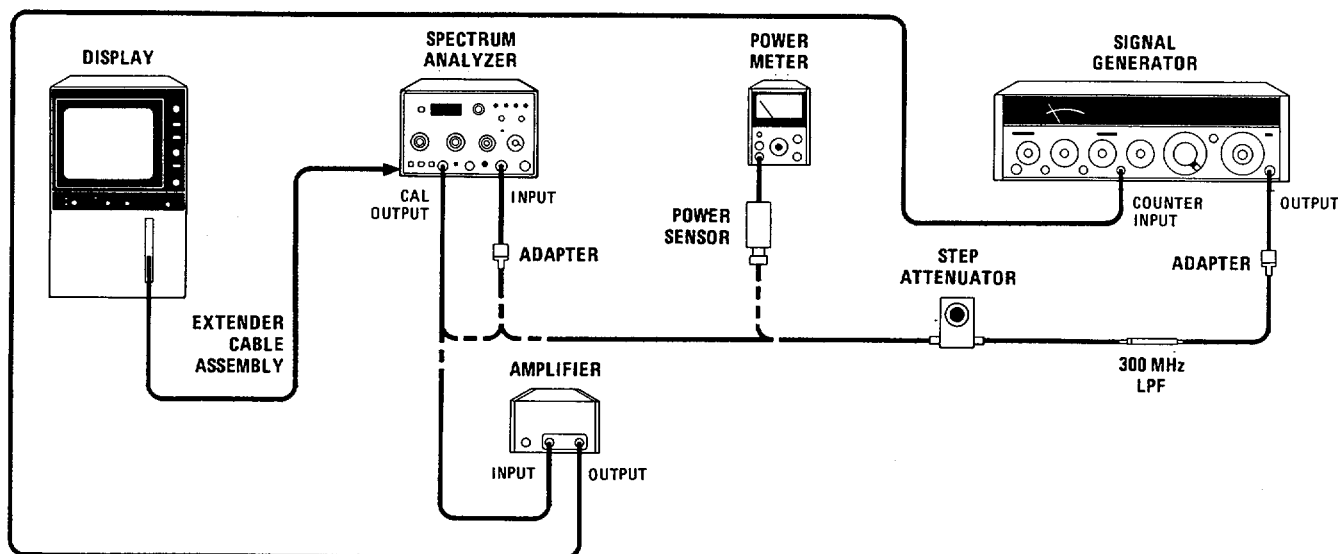

Figure 5-3. Third Converter LO and CAL OUTPUT Adjustment Test Setup

EQUIPMENT

Amplifier	HP 8447A
Power Meter.....	HP 435B
Power Sensor.....	HP 8482A
Signal Generator.....	HP 8640B
10 dB Step Attenuator (calibrated at 280 MHz).....	HP 355D, Opt. H82
300 MHz LPF	Telonic TLP 300-4AB
Adapter, Type N (m) to BNC (f) (2 required).....	HP 1250-0780

Additional Equipment, Options 001 and 002:

Power Sensor, 75W, HP 8483A	
Minimum Loss Adapter, 75W to 50W.....	HP 08558-60031
Adapter, BNC(m) to BNC(m), 75W	HP 1250-1288
BNC Cable, 30 cm (12 in), 75W	HP 11652-60012

ADJUSTMENTS

5-18. THIRD CONVERTER LO AND CAL OUTPUT ADJUSTMENT (Cont'd)

PROCEDURE

1. Set equipment as follows:

START- CENTER CENTER
 TUNING 280 MHz
 FREQ SPAN/DIV 500 kHz
 RESOLUTION BW 1 MHz
 INPUT ATTEN 10 dB
 REFERENCE LEVEL dBm -20
 002: + 30 dBm V
 Amplitude Scale LIN
 SWEEP TIME/DIV AUTO
 Extender Cable Assembly HP 5060-0303

Signal Generator:

OUTPUT LEVEL + 10 dBm
 FREQUENCY 280 MHz
 AM OFF
 FM OFF
 RF ON
 COUNTER MODE INT

2. Connect equipment as shown in Figure 5-3. Connect CAL OUTPUT to INPUT 50(connector.
 001 and 002: 75W
3. Center the 280 MHz signal on the display.
4. Adjust A9L4 third converter LO FREQ adjustment for maximum signal amplitude.
5. Tune signal generator to frequency of third converter LO (280 MHz ±300 kHz).
6. Connect signal generator through 300 MHz LPF to calibrated step attenuator. Set step attenuator to 10 dB.
7. Connect power sensor and power meter to step attenuator as shown in Figure 5-3.
8. Set signal generator OUTPUT LEVEL for a 0 dBm full scale reading on power meter. Leave signal generator set at this level.

001: +5.7 dBm
 002: + 7.0

9. Set step attenuator to 40 dB and connect the reference signal set in step 8 (from signal generator through step attenuator) to the 8558B INPUT 50Ω connector.

001 and 002: INPUT 75W connector using Minimum Loss Adapter and 75W BNC Cable.

ADJUSTMENTS

5-18. THIRD CONVERTER LO AND CAL OUTPUT ADJUSTMENT (Cont'd)

10. Set signal from signal generator to a convenient reference level on display with REFERENCE LEVEL and REF LEVEL FINE controls.
 11. Disconnect signal generator and connect spectrum analyzer CAL OUTPUT to the INPUT 500 connector.
001 and 002: 75W
 12. Adjust A9R5 3RD LO PWR adjustment, accessible from bottom of analyzer through motherboard, to the reference set in step 10. (If range is insufficient on A9R5, change value of factory-selected resistor A9R4*.)
 13. Connect CAL OUTPUT to amplifier input and connect amplifier output to COUNTER INPUT of 8640B. Set HP 8640B COUNTER MODE to EXT EXPAND X10. The third LO frequency should read 280 MHz \pm 300 kHz.
-

ADJUSTMENTS

5-19. SLOPE ADJUSTMENT

REFERENCE

A9 Schematic

DESCRIPTION

An externally leveled signal is applied to the INPUT of the spectrum analyzer. The signal is adjusted across the frequency range of the spectrum analyzer. A9R1 SLOPE COMP is adjusted for best flatness, compensating for first converter conversion loss over frequency.

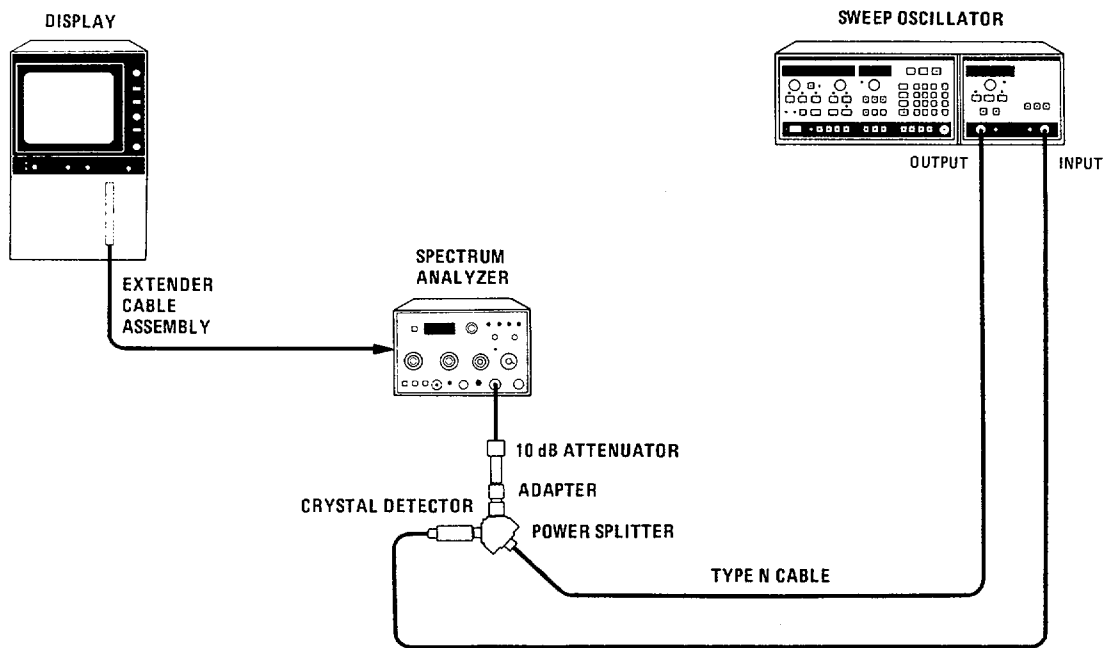

CONFIGURATION FOR OPTION 001, 002

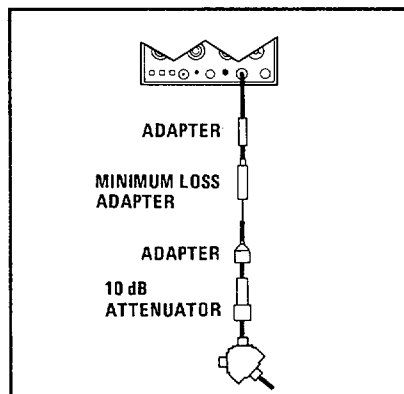

Figure 5-4. Slope Adjustment Test Setup

ADJUSTMENTS

5-19. SLOPE ADJUSTMENT (Cont'd)

EQUIPMENT

Sweep Oscillator*	HP 8350A
RF Plug-In*	HP 83522A
Power Splitter	HP 11667A
Crystal Detector	HP 423B
10-dB Attenuator	HP 8491B Opt. 010
Adapter, Type N (m) to Type N (m)	HP 1250-1475
BNC Cable, 120 cm (48 in)	HP 10503A
Type N Cable	HP 11500A
Extender Cable Assembly	HP 5060-0303

*8620C/86222A may be substituted

Additional Equipment, Options 001 and 002:

Minimum Loss Adapter, 75 Ω to 50 Ω	HP 08558-60031
Adapter, BNC(m) to BNC (m), 75 Ω	HP 1250-1288
Adapter, Type N (m) to SMA (f)	HP 1250-1250

PROCEDURE

1. Set equipment as follows:

Spectrum Analyzer

START - CENTER	CENTER
TUNING	500 MHz
FREQ SPAN/DIV	100 MHz
RESOLUTION BW	1 MHz
INPUT ATTEN	10 dB
REFERENCE LEVEL	-10 dBm
002: +40dBmV	
REF LEVEL FINE	0
Amplitude Scale	1 dB/DIV
SWEEP TIME/DIV	AUTO
BASELINE CLIPPER	OFF
VIDEO FILTER	OFF

Sweep Oscillator

START	10 MHz
STOP	1.5 GHz
SWEEP	MAN
POWER LEVEL	0 dBm
ALC MODE	EXT
FREQUENCY/TIME	500 MHz

2. Connect equipment as shown in Figure 5-4.

ADJUSTMENTS

5-19. SLOPE ADJUSTMENT (Cont'd)

3. Adjust spectrum analyzer REF LEVEL FINE to bring signal peak on display.
 4. Set spectrum analyzer START - CENTER to CENTER. Manually tune sweep oscillator for output frequencies from 10 MHz to 1.0 GHz. Set spectrum analyzer START - CENTER to START. Manually tune sweep oscillator for output frequencies from 1.0 GHz to 1.5 GHz.
 5. Using procedure of step 4, locate highest displayed amplitude. Adjust spectrum analyzer REF LEVEL FINE to bring highest displayed amplitude to fifth CRT graticule line from bottom.
 6. Using procedure of step 4, locate lowest displayed amplitude.
 7. Adjust spectrum analyzer A9R1 SLOPE COMP for minimum difference between highest and lowest displayed amplitudes.
 8. Repeat steps 5, 6, and 7 until no further adjustment is necessary.
 9. With highest displayed amplitude set to fifth graticule line from bottom lowest displayed amplitude should be at or above third graticule line from bottom.
-

ADJUSTMENTS

5-20. SECOND IF BANDPASS AMPLIFIER AND BANDPASS FILTER ADJUSTMENT

REFERENCE

A10 Schematic

DESCRIPTION

Tune bandpass amplifier output and bandpass filter.

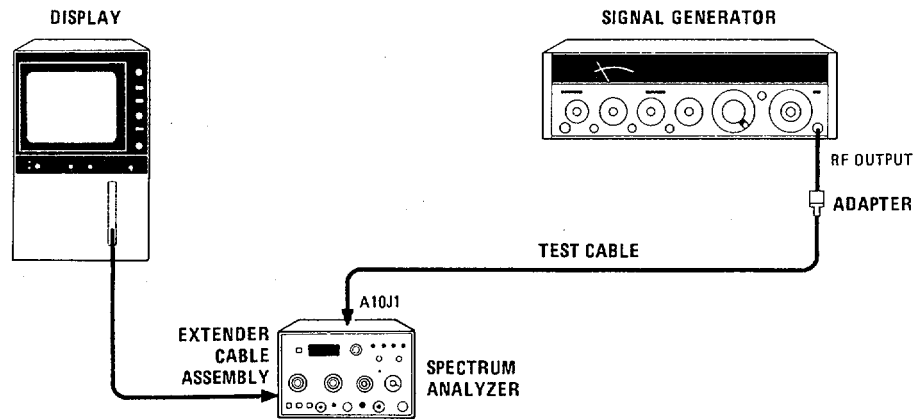

Figure 5-5. Second IF Bandpass Amplifier and Bandpass Filter Adjustment Test Setup

EQUIPMENT

Signal Generator	HP 8640B
Adapter, Type N (m) to BNC (f)	HP 1250-0780
Test Cable, SMC (f) to BNC (m)	HP 11592-60001
Extender Cable Assembly	HP 5060-0303

PROCEDURE

1. Set spectrum analyzer controls as follows:

FREQ SPAN/DIV	100 MHz
RESOLUTION	1 MHz
INPUT ATTEN	0 dB
REFERENCE LEVEL	- 10 dBm
002: +40 dBmV	
Amplitude Scale	10 dB/DIV
SWEEP TIME/DIV	AUTO
SWEEP TRIGGER	FREE RUN

2. Set signal generator frequency to 301.4 MHz and set output level to approximately - 35 dBm.

ADJUSTMENTS

5-20. SECOND IF BANDPASS AMPLIFIER AND BANDPASS FILTER ADJUSTMENT (Cont'd)**NOTE**

If 8640B is not used, adjust the signal generator for maximum signal on the display in step 3.

3. Remove W6P2 from Second IF A10J1. Connect signal generator through test cable to A10J1 as shown in Figure 5-5.
4. Adjust bandpass filter capacitors A10C1, A10C2, and A10C3 on Second IF Assembly fully counterclockwise. Adjust REFERENCE LEVEL if necessary for an on-screen display.
5. Adjust A10C1 for maximum signal amplitude. Make final adjustment with Amplitude Scale switch in LIN position. Leave switch in LIN position. Use REFERENCE LEVEL and REF LEVEL FINE controls to keep signal on top half of display.
6. Adjust A10C3 for maximum signal amplitude. There may be a double peak; tune past first peak to second peak. Signal on display will peak and fall off slightly and then peak again.
7. Repeat steps 5 and 6 adjusting A10C1 and A10C3 for maximum amplitude.
8. Adjust A10C2 for maximum signal amplitude. There may be a double peak; tune to second peak. Reduce input signal level to keep signal on display.

NOTE

The following adjustment of A10L2 has very little effect on the signal or performance of the spectrum analyzer. A10L2 need not be adjusted because the position of the core is not critical.

9. Adjust A10L2 2ND IF TUNING adjustment for maximum signal amplitude. L2 is adjusted through motherboard on bottom of analyzer. Reconnect W6P2 to A10J1.

ADJUSTMENTS

5-21. CRYSTAL AND LC BANDWIDTH FILTER ADJUSTMENTS

REFERENCE

A8, A11, and A13 Schematics

DESCRIPTION

The crystal and LC bandwidth filter circuits are adjusted for symmetry, center, and peak. Three-dB bandwidths are adjusted on the Sweep Generator Assembly A8 (paragraph 5-22).

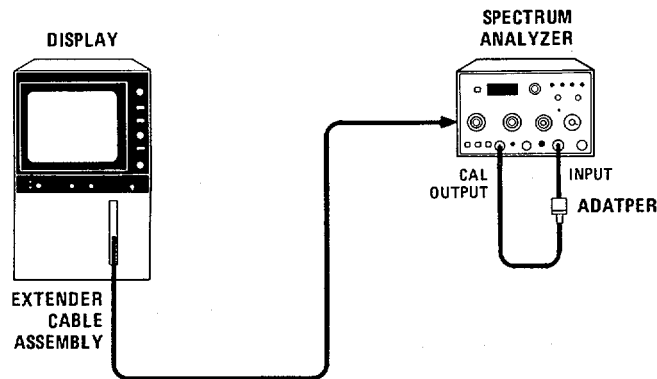

Figure 5-6. Crystal and LC Bandwidth Filter Adjustment Test Setup

EQUIPMENT

Adapter, Type N (m) to BNC (f)	HP 1250-0780
BNC Cable, 20 cm (9 in)	HP 10502A
Crystal Short (3 Required)	See Figure 5-7.
Extender Cable Assembly	HP 5060-0303

Additional Equipment, Options 001 and 002:

BNC Cable, 30 cm (12 in), 75W	HP 11652-60012
-------------------------------------	----------------

NOTE

A crystal short consists of a .01 μ F capacitor (HP Part No. 0160-0161) and a 90.9 ohm resistor (HP Part No. 0757-0400) connected in series. Two square-terminal connectors (HP Part No. 0362-0265) are used to connect the crystal short across the test points.

ADJUSTMENTS

5-21. CRYSTAL AND LC BANDWIDTH FILTER ADJUSTMENTS (Cont'd)

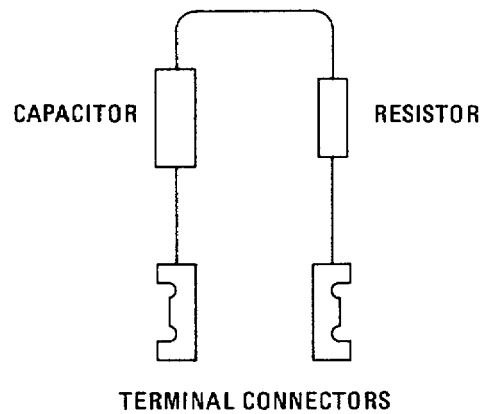

Figure 5-7. Crystal Short Configuration

PROCEDURE

NOTE

Allow 30 minutes warmup time before performing adjustments.

1. Set spectrum analyzer controls as follows:

START- CENTER	CENTER
TUNING	280 MHz
FREQ SPAN/DIV	5 kHz
RESOLUTION BW	1 kHz
INPUT ATTEN	0 dB
REFERENCE LEVEL	-20 dBm
002: + 30 dBmV	
Amplitude Scale	LIN
SWEEP TIME/DIV	10 mSEC
SWEEP TRIGGER	FREE RUN

Crystal Alignment

2. Connect equipment as shown in Figure 5-6.

NOTE

If A8 Sweep Generator has been replaced or adjusted, perform steps 3 through 9. If not, proceed to step 10.

3. Set FREQ SPAN/DIV to 500 kHz and RESOLUTION BW to 1 MHz.
4. Center the signal with TUNING control. Using REF LEVEL FINE control, place signal at 7.1 divisions (0.9 division from top graticule line).

ADJUSTMENTS

5-21. CRYSTAL AND LC BANDWIDTH FILTER ADJUSTMENTS (Cont'd)

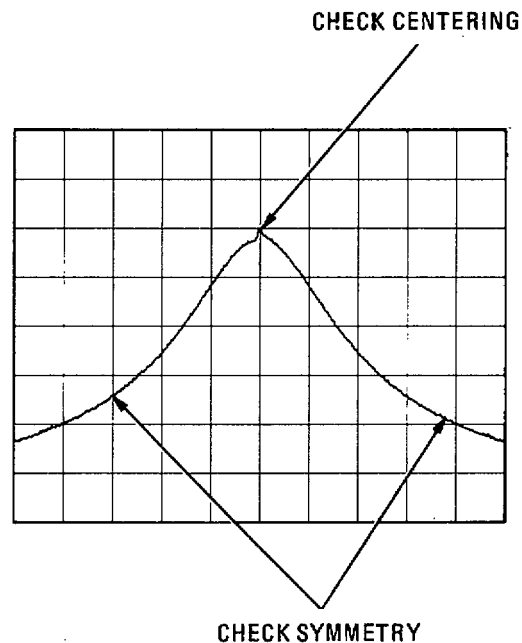

Figure 5-8. Adjusting Crystal Symmetry and Crystal Centering

5. Adjust A8R85 LC until signal is two divisions wide at the fifth graticule line (1 MHz wide at 3-dB points).
6. Set FREQ SPAN/DIV to 5 kHz and RESOLUTION BW to 10 kHz.
7. Using REF LEVEL FINE control, place signal at 7.1 divisions.
8. Adjust A8R72 XTL until signal is two divisions wide at the fifth graticule line (10 kHz wide at 3-dB points).
9. Set FREQ SPAN/DIV to 5 kHz and RESOLUTION BW to 1 kHz.
10. Center signal with TUNING control. (It might be necessary to increase FREQ SPAN/DIV temporarily to find the signal.) Set REF LEVEL FINE control to place signal at sixth graticule line.
11. Set FREQ SPAN/DIV to 20 kHz and RESOLUTION BW to 30 kHz.

NOTE

A non-metallic tuning tool is required for adjustments on the A11 and A13 bandwidth filter assemblies.

12. Connect crystal shorts (through cover access holes) across A13TP1/TP2, A11TP1/TP2, and A11TP4/TP5.

ADJUSTMENTS

5-21. CRYSTAL AND LC BANDWIDTH FILTER ADJUSTMENTS (Co nt'd)**NOTE**

Keep crystal spike centered during adjustments. The SYM and CTR adjustments for each crystal interact.

13. Adjust front-panel TUNING control to center bandpass spike (Figure 5-8) on the CRT display.
14. Adjust A13C38 SYM and A13C54 CTR for a centered and symmetrical bandpass as shown in Figure 5-8. Adjust A13C54 CTR for minimum signal amplitude.
15. Remove crystal short from A13TP1/TP2 and connect it across A13TP4/TP5.
16. Adjust A13C15 SYM and A13C25 CTR for a centered and symmetrical bandpass. Adjust A13C25 CTR for minimum signal amplitude.
17. Remove crystal short from A11TP4/TP5 and connect it across A13TP1/TP2.
18. Adjust A11C38 SYM and A11C54 CTR for a centered and symmetrical bandpass. Adjust A11C54 CTR for minimum signal amplitude.
19. Remove crystal short from A11TP1/TP2 and connect it across A11TP4/TP5.
20. Adjust A11C15 SYM and A11C25 CTR for a centered and symmetrical bandpass. Adjust A11C25 CTR for minimum signal amplitude.
21. Remove the crystal shorts.

LC Alignment

22. Perform preliminary LC filter adjustments as follows:
 - a. Install A13 on extender board. Set RESOLUTION BW control to 100 kHz.
 - b. Short to ground the following test points: A13TP6, A11TP3, and A11TP6. Jumper A8TP1 to A8TP2.
 - c. Adjust A13C73 for minimum signal amplitude.
 - d. Disconnect short from A13TP6 and short to ground A13TP3.
 - e. Adjust A13C74 for minimum signal amplitude.
 - f. Reinstall A13 and install A11 on extender board.
 - g. Disconnect short from A11TP3 and short to ground A13TP6.
 - h. Adjust A11C73 for minimum signal amplitude.
 - i. Disconnect short from A11TP6 and short to ground A11TP3.

ADJUSTMENTS

5-21. CRYSTAL AND LC BANDWIDTH FILTER ADJUSTMENTS (Cont'd)

- j. Adjust A11C74 for minimum signal amplitude.
- k. Disconnect shorts from test points and reinstall A11. Replace covers on A11 and A13 assemblies. Remove jumper from A8TP1/A8TP2.

NOTE

When A11 and A13 BW Filter Assemblies are installed with covers in place, midget copper alligator clips (HP Part No. 1400-0483) can be used to short test points to the cover.

- 23. Carefully center signal on CRT in 30 kHz RESOLUTION BW; then switch RESOLUTION BW to 100 kHz. Note where signal intersects the center vertical graticule line.
- 24. Adjust A13C45 LC CTR for maximum signal amplitude where the signal intersects the center vertical graticule line.
- 25. Switch RESOLUTION BW to 30 kHz and center signal; then switch to 100 kHz. Note where signal intersects the center vertical graticule line.
- 26. Adjust A13C23 LC CTR for maximum signal amplitude where the signal intersects the center vertical graticule line.
- 27. Switch RESOLUTION BW to 30 KHz and center signal; then switch to 100 kHz. Note where signal intersects the center vertical graticule line.
- 28. Adjust A11C45 LC CTR for maximum signal amplitude where the signal intersects the center vertical graticule line.
- 29. Switch RESOLUTION BW to 30 kHz and center signal; then switch to 100 kHz. Note where signal intersects the center vertical graticule line.
- 30. Adjust A11C23 LC CTR for maximum signal amplitude where the signal intersects the center vertical graticule line.
- 31. Switch RESOLUTION BW between 100 kHz and 30 kHz to be sure the signal is centered at both bandwidth settings.
- 32. Set FREQ SPAN/DIV to 5 kHz and RESOLUTION BW to 1 kHz. Center signal with TUNING control.

Bandwidth Amplitude

- 33. Set A11R31 XTL and A13R31 XTL fully counterclockwise.
- 34. Set Amplitude Scale switch to 1 dB/DIV.
- 35. Jumper A8TP1 to A8TP2. Short A11TP3, A11TP6, A13TP3, and A13TP6 to ground.

ADJUSTMENTS

5-21. CRYSTAL AND LC BANDWIDTH FILTER ADJUSTMENTS (Cont'd)

36. Set RESOLUTION BW to 1 MHz and FREQ SPAN/DIV to 50 kHz.
37. Adjust fine TUNING and REF LEVEL FINE for a centered signal at 7 divisions.
38. Remove shorts from A13TP3 and A13TP6 and center signal with fine TUNING control. Adjust A13R26 LC for a signal amplitude of 7 divisions.
39. Remove shorts from A11TP3 and A11TP6. Adjust A11R26 LC for a signal amplitude of 7 divisions.
40. Repeat steps 35 through 39 until no further adjustment is necessary.
41. Set RESOLUTION BW to 1 kHz and FREQ SPAN/DIV to 5 kHz. Center signal with fine TUNING control. Adjust A11 R31 XTL and A13R31 XTL equally for a signal amplitude of 7 divisions.

NOTE

Each potentiometer should be adjusted to accomplish half the necessary increase in signal amplitude.

42. Remove jumper from A8TP1 and A8TP2.
 43. Set FREQ SPAN/DIV to 100 MHz and RESOLUTION BW to 3 MHz and push in to couple the two controls.
 44. Turn coupled controls to set FREQ SPAN/DIV to 50 MHz and RESOLUTION BW to 1 MHz. Center signal with TUNING control. Adjust REF LEVEL FINE for a signal amplitude of 7 divisions.
 45. With controls coupled, step down RESOLUTION BW from 1 MHz to 300 kHz. Variation in signal amplitude should be less than ± 0.4 dB.
 46. Step down RESOLUTION BW from 100 kHz to 1 kHz. Variation of signal amplitude should be less than ± 0.5 dB.
 47. Repeat steps 35 through 46 until variation in signal amplitude is within limits.
-

ADJUSTMENTS

5-22. 3-dB BANDWIDTH ADJUSTMENT

REFERENCE

A8 Schematic

DESCRIPTION

The 3-dB bandwidths for the 3 MHz, 1 MHz and 300 kHz RESOLUTION BW settings are adjusted using the CAL OUTPUT as the signal source. The 3-dB bandwidths for the 10 kHz, 3 kHz, and 1 kHz RESOLUTION BW settings are adjusted by injecting a stable 301.4 MHz signal into the third converter of the spectrum analyzer.

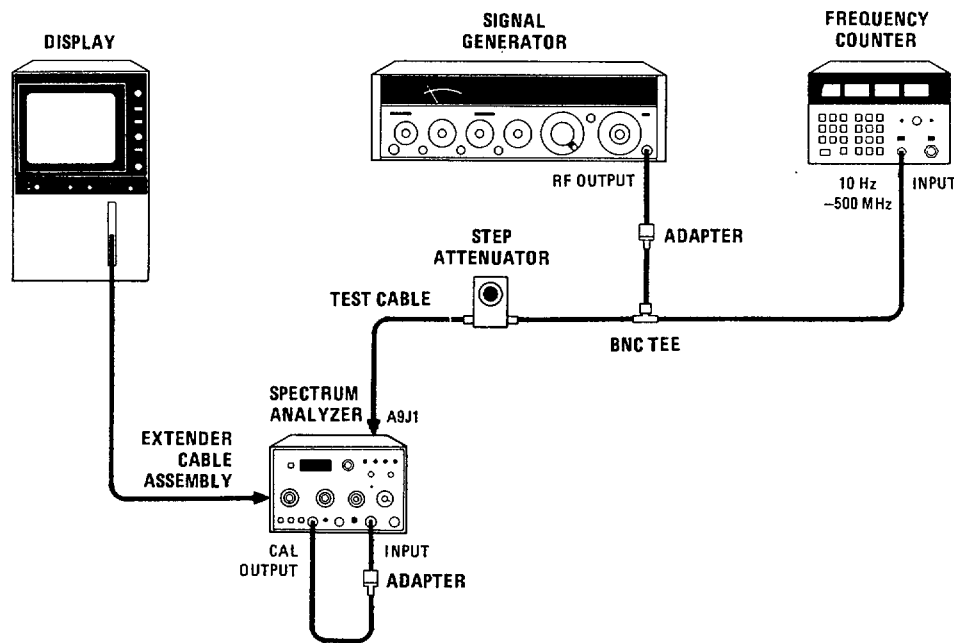

Figure 5-9. 3-dB Bandwidth Adjustment Test Setup

EQUIPMENT

Signal Generator	HP 8640B
Frequency Counter	HP 5343A
10 dB Step Attenuator	HP 355D
BNC Cable, 20 cm (9 in)	HP 10502A
Adapter, Type N (m) to BNC (f) (3 required)	HP 1250-0780
BNC Tee	HP 1250-0781
Test Cable, SMC (f) to BNC (m)	HP 11592-60001
Extender Cable Assembly	HP 5060-0303

ADJUSTMENTS

5-22. 3-dB BANDWIDTH ADJUSTMENT (Cont'd)

PROCEDURE

1. Set spectrum analyzer controls as follows:

START - CENTER	CENTER
TUNING	280 MHz
FREQ SPAN/DIV	200 kHz
RESOLUTION BW	1 MHz
INPUT ATTEN	0 dB
REFERENCE LEVEL	-20 dBm
Amplitude Scale	LIN
SWEEP TIME/DIV	1 mSEC
SWEEP TRIGGER	FREE RUN
VIDEO FILTER	OFF

2. Connect equipment as shown in Figure 5-9 except for signal input to A9J1. Connect CAL OUTPUT to spectrum analyzer INPUT 50(.
3. Set signal level of 7.1 divisions on display with REF LEVEL FINE control. (Signal should be 0.9 division from top graticule line.)
4. Set RESOLUTION BW to 1 MHz and FREQ SPAN/DIV to 200 kHz. Adjust A8R85 LC to set bandwidth of 5 divisions at the fifth graticule line.
5. Set RESOLUTION BW to 3 MHz and FREQ SPAN/DIV to 500 kHz. The bandwidth at the fifth graticule line should be between 5.4 and 6.6 divisions.

NOTE

A8R85 LC may be further adjusted to bring the 3 MHz and 300 kHz bandwidths within limits; however, the final measurement of the 1 MHz bandwidth must be between 4.5 and 5.5 divisions at the fifth graticule line. (If the 3 MHz bandwidth cannot be brought within limits by adjustment of A8R85 LC, change the value of factory-selected resistor A8R95*.)

6. Set RESOLUTION BW to 300 kHz and FREQ SPAN/DIV to 50 kHz. The bandwidth should be between 5.4 and 6.6 divisions at the fifth graticule line. (If the bandwidth cannot be adjusted within the specified limits, change the value of factory-selected resistor A8R89*.)
7. Set RESOLUTION BW to 100 kHz and FREQ SPAN/DIV to 20 kHz. The bandwidth should be between 4.3 and 5.7 divisions at the fifth graticule line.

NOTE

If the 100 kHz bandwidth is not within the specified limits, change the values of factory-selected resistors A13R19*, A13R43*, and A11R43*. If the bandwidth is too wide, increase the value of the resistors; if the bandwidth is too narrow, decrease the value of the resistors. The three factory-selected resistors need not be of equal value, but each must be within one standard value of the others.

ADJUSTMENTS

5-22. 3-dB BANDWIDTH ADJUSTMENT (Cont'd)

8. Set RESOLUTION BW to 30 kHz and FREQ SPAN/DIV to 5 kHz. The bandwidth should be between 5.2 and 6.8 divisions at the fifth graticule line.

NOTE

If the 30 kHz bandwidth is not within the specified limits, change the values of factory-selected resistors A11R23*, A11R48*, A13R23*, and A13R48*. If the bandwidth is too wide, decrease the value of the factory selected resistors; if the bandwidth is too narrow, increase the value of the resistors. The four factory-selected resistors need not be of equal value, but each must be within one standard value of the others.

9. Connect signal generator through the BNC Tee connector to the step attenuator and to the frequency counter as shown in Figure 5-9. Set the signal generator to approximately 0 dBm and the step attenuator to 30 dB. Set COUNTER MODE to EXPAND X100.
 10. Remove W7P2 from Third Converter A9J1. Connect step attenuator through test cable to A9J1.
 11. Set HP 8558B RESOLUTION BW to 1 MHz. Tune signal generator to peak signal on CRT display (near 301.4 MHz). Adjust the output level of signal generator to place the signal at 7.1 divisions.
 12. Set RESOLUTION BW to 3 kHz. Tune signal generator to peak signal on CRT display.
 13. Adjust REF LEVEL FINE to place signal at 7.1 divisions.
 14. Note the counter frequency and tune the signal generator 1500 Hz below the center frequency noted. Record the new counter frequency.
 15. Adjust A8R72 XTL to bring signal level to the fifth graticule line (three divisions from the top graticule line).
 16. Increase signal generator frequency until signal on CRT display peaks and then decreases to the fifth graticule line. Record counter frequency.
 17. Compare new frequency with frequency recorded in step 14. The difference between the two frequencies should be 2800 to 3200 Hz. If the bandwidth is not within limits, repeat steps 12 through 17, slightly readjusting A8R72 XTL, until the specified limits are achieved.
 18. Set RESOLUTION BW to 10 kHz. Tune signal generator to peak signal on CRT display.
 19. Adjust REF LEVEL FINE to place signal at 7.1 divisions.
 20. Note the counter frequency and tune the signal generator 5 kHz below the center frequency noted. Record the new counter frequency.
 21. Increase the signal generator frequency until the signal on the CRT display peaks and then decreases to the fifth graticule line. Record counter frequency.
 22. Compare new frequency with frequency recorded in step 20. The difference between the two frequencies should be 9.000 kHz to 11.000 kHz.
-

ADJUSTMENTS

5-22. 3-dB BANDWIDTH ADJUSTMENT (Cont'd)**NOTE**

A8R72 XTL may be further adjusted to bring the 10 kHz and 1 kHz bandwidths within limits; however, the final measurement of the 3 kHz bandwidth must be between 2700 Hz and 3300 Hz. (If the 10 kHz bandwidth cannot be brought within limits by adjustment of A8R72 XTL, change the value of factory-selected resistor A8R78*.)

23. Set RESOLUTION BW to 1 kHz. Tune signal generator to peak signal on CRT display.
 24. Adjust REF LEVEL FINE to place signal at 7.1 divisions.
 25. Note the counter frequency. Increase signal generator frequency until signal on CRT display peaks and then decreases to the fifth graticule line. Record new counter frequency.
 26. Compare new frequency with frequency originally noted in step 25. The difference between the two frequencies should be 450 Hz to 550 Hz.
 27. Reconnect W7P2 to A9J1.
-

ADJUSTMENTS

5-23. STEP GAIN ASSEMBLY RF GAIN ADJUSTMENT

REFERENCE

A12 Schematic

DESCRIPTION

The RF gain (sensitivity) of the Step Gain assembly is adjusted by injecting a 21.4 MHz signal at A16XA9. The Third Converter Assembly A9 is removed and replaced with a special extender board for applying the 21.4 MHz signal from the signal generator.

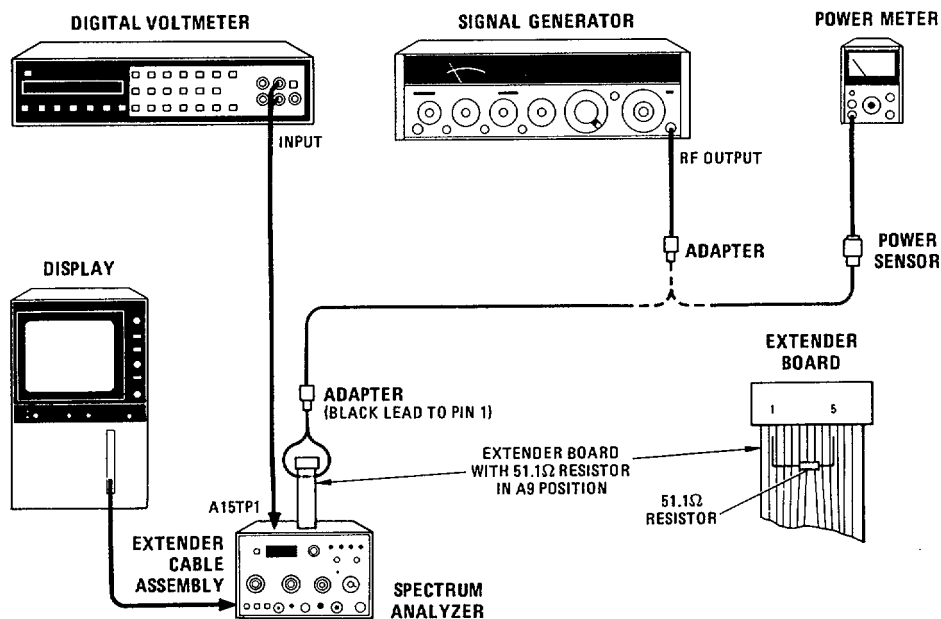

Figure 5-10. Step Gain Assembly RF Gain Adjustment Test Setup

EQUIPMENT

Signal Generator	HP 8640B
Digital Voltmeter	HP 3455A
Power Meter.....	HP 435B
Power Sensor.....	HP 8482A
Adapter, BNC (f) to alligator clips	HP 8120-1292
Special Extender Board with 51.1-ohm resistor	HP 08505-60109/0757-0394
BNC Cable, 120 cm (48 in)	HP 10503A
Extender Cable Assembly	HP 5060-0303

NOTE

To make special extender board, solder 51.1 ohm resistor from pin 1 to pin 5 of standard extender board, HP Part No. 5060-0257. Leave resistor leads long for easy connection of clip leads.

ADJUSTMENTS

5-23. STEP GAIN ASSEMBLY RF GAIN ADJUSTMENT (Cont'd)

PROCEDURE

1. Set equipment as follows:

Spectrum Analyzer

FREQ SPAN/DIV 1 MHz
 RESOLUTION BW 1 MHz
 INPUT ATTEN 10 dB
 REFERENCE LEVEL 0 dBm
 002: + 50 dBmV
 REF LEVEL FINE 0
 Amplitude Scale LIN
 SWEEP TIME/DIV AUTO
 SWEEP TRIGGER FREE RUN
 VIDEO FILTER OFF

Digital Voltmeter

RANGE AUTO
 FUNCTION DC Volts
 TRIGGER INTERNAL
 MATH OFF
 AUTO CAL.: ON

2. Connect equipment as shown in Figure 5-10.
3. Set signal generator frequency to 21.4 MHz. Set OUTPUT LEVEL for approximately - 5 dBm.
4. Connect output of signal generator across 51.1 ohm resistor on special board using BNC to clip-lead adapter. The red lead (center conductor) should be connected to pin 5 of extender board.
5. Set signal generator frequency for peak amplitude on CRT display. Connect output of signal generator to power meter through power sensor and set OUTPUT LEVEL to - 1 dBm. Reconnect signal generator output to clip-lead adapter.

001: -5 dBm
 002: - 6 dBm

6. Adjust A12R4 GAIN adjustment for signal one division from top graticule line. DVM should indicate + 700 mV \pm 30 mV. Remove special extender board and replace Third Converter Assembly A9.

NOTE

Front panel VERTICAL GAIN and VERTICAL POSN control settings can affect the voltage measured at A15TP1. Vertical calibration should be checked after adjusting A12R4 for 700 mV. (Refer to Operator's Check, Section III).

ADJUSTMENTS

5-24. STEP AMPLIFIER GAIN ADJUSTMENTS

REFERENCE

A12 Schematic

DESCRIPTION

REF LEVEL FINE, 0 dB, and -12 dB adjustments are properly set and step gains of 10 dB, 20 dB, and 40 dB are adjusted.

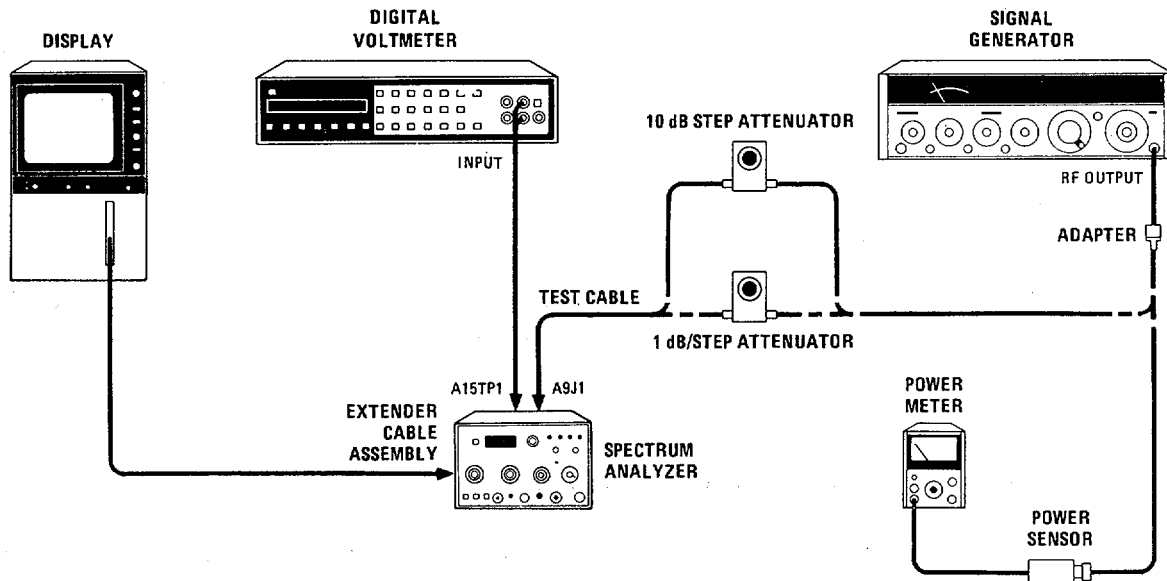

Figure 5-11. Step Amplifier Gain Adjustment Test Setup

EQUIPMENT

Signal Generator.....	HP 8640B
1-dB Step Attenuator.....	HP 355C Opt. H80
10-dB Step Attenuator.....	HP 355D Opt. H82
Digital Voltmeter	HP 3455A
Power Meter.....	HP 435B
Power Sensor.....	HP 8482A
Adapter, Type N (m) to BNC (f).....	HP 1250-0780
Test Cable, SMC (f) to BNC (m).....	HP 11592-60001
Adapter, SMC (m) to SMC (m).....	HP 1250-0827
Extender Cable Assembly	HP 5060-0303

ADJUSTMENTS

5-24. STEP AMPLIFIER GAIN ADJUSTMENTS (Cont'd)

PROCEDURE

1. Set equipment as follows:

TUNING 280 MHz
 FREQ SPAN/DIV 1 MHz
 RESOLUTION BW 1 MHz
 INPUT ATTEN 10 dB
 REFERENCE LEVEL 0 dBm
 002: + 50 dBm V
 Amplitude Scale 1 dB/DIV
 SWEEP TIME/DIV AUTO
 SWEEP TRIGGER FREE RUN
 VIDEO FILTER OFF

2. Connect equipment as shown in Figure 5-11. Connect signal generator tuned to 301.4 MHz with approximately -13 dBm output to one side of a 1 dB/step attenuator. Connect attenuator output to A9J1 through test cable. Tune signal generator frequency for peak amplitude on display.
3. Set step attenuator to 12 dB and REF LEVEL FINE to -12. Set signal generator level for a signal one division down from top graticule line.
4. Adjust A12R6 -12 dB until signal stops rising on display, then adjust A12R6 counterclockwise until signal drops approximately one third to one half of a division.
5. Set signal generator level so signal is one division down from top graticule line on display.
6. Set step attenuator to 0 dB and REF LEVEL FINE to 0.
7. Adjust A12R5 0 dB adjustment for a signal level one division from top graticule line.
8. Set step attenuator to 12 dB and REF LEVEL FINE to -12. Signal level on display should be ± 0.1 division from the reference one division down from top graticule line. If signal level is out of limits, repeat steps 3 through 8 until the signal level is within limits.
9. Check REF LEVEL FINE control from 0 to -12 dBm, as shown in Table 5-5. Verify correct operation on display, or measure voltage at A15TP1 with digital voltmeter.

NOTE

Be sure all covers in the IF section are secured by at least six screws before proceeding. If covers are left off or not secured by at least six screws, leakage between assemblies may occur. This leakage causes erroneous adjustment.

10. Replace 1 dB/step attenuator with 10 dB/step attenuator set to 0 dB. Set REF LEVEL FINE control to 0.

ADJUSTMENTS

5-24. STEP AMPLIFIER GAIN ADJUSTMENTS (Cont'd)

Table 5-5. REF LEVEL FINE Control Check

REF LEVEL FINE Setting	Step Attenuator Setting (dB)	Deviation From Reference
0	0	Ref. _____ mV (Ref.)
-1	1	±0.3 Div ±30 mV
-2	2	±0.3 Div ±30 mV
-3	3	±0.3 Div ±30 mV
-4	4	±0.3 Div ±30 mV
-5	5	±0.3 Div ±30 mV
-6	6	±0.3 Div ±30 mV
-7	7	±0.3 Div ±30 mV
-8	8	±0.3 Div ±30 mV
-9	9	±0.3 Div ±30 mV
-10	10	±0.3 Div ±30 mV
-11	11	±0.3 Div ±30 mV
-12	12	±0.3 Div ±30 mV

11. Connect power sensor and power meter to attenuator output and adjust signal generator output level for a power meter reading of - 13 dBm. Connect test cable from attenuator to A9J1.
12. Tune signal generator frequency for peak amplitude on the display (near 301.4 MHz).
13. Set step attenuator to 10 dB and REFERENCE LEVEL to - 10 dBm.
002: +40dBmV
14. Adjust A12R3 10 dB adjustment for signal level one division from top graticule line.
15. Set step attenuator to 20 dB and REFERENCE LEVEL to - 20 dBm.
002: + 30 dBmV
16. Adjust A12R2 20 dB adjustment for signal level one division from top graticule line.
17. Set attenuator to 40 dB and REFERENCE LEVEL to - 40 dBm.
002: +10dBmV

NOTE

Some video filtering might help reduce noise. Set VIDEO FILTER control so noise is reduced, but the signal amplitude remains unchanged.

18. Adjust A12R1 40 dB adjustment for signal level one division from top graticule line.
-

ADJUSTMENTS

5-24. STEP AMPLIFIER GAIN ADJUSTMENTS (Cont' d)

19. Check REFERENCE LEVEL control from 0 to - 50 dBm as shown in Table 5-6.

002: + 50 dBmV to 0 dBm V. REFERENCE LEVEL dBmV settings in Table 5-6 are, from top to bottom, + 50, + 40, + 30, + 20, + 10, 0.

20. Reconnect W7P2 to A9J1.

Table 5-6. REFERENCE LEVEL Control Check

REFERENCE LEVEL (dBm)	Attenuator (dB)	Deviation From Reference
0	0	Reference
-10	10	± 0.2 Div ± 20 mV
-20	20	± 0.2 Div ± 20 mV
-30	30	± 0.2 Div ± 20 mV
-40	40	± 0.2 Div ± 20 mV
-50	50	± 0.2 Div ± 20 mV

ADJUSTMENTS

5-25. + 19.5V ADJUSTMENT

REFERENCE

A12 Schematic

DESCRIPTION

+ 19.5V for YIG Oscillator is adjusted.

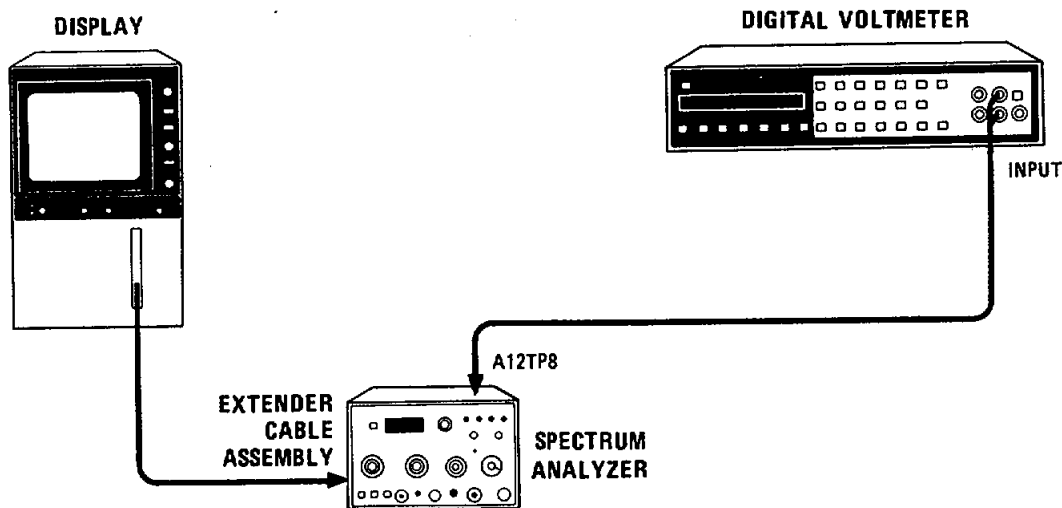

Figure 5-12. +19.5V Adjustment Test Setup

EQUIPMENT

Digital Voltmeter.....	HP 3455A
Cable, Banana Plug to Alligator Clip.....	HP 11102A
Extender Cable Assembly	HP 5060-0303

PROCEDURE

1. Set Digital Voltmeter as follows:

RANGE	AUTO
FUCTION	dcV
AUTO CAL	ON
TRIGGER.....	INTERNAL

2. Connect equipment as shown in Figure 5-12. Connect digital voltmeter to A12TP8 (left side of A12R7 + 19.5V adjustment).
3. Adjust A12R7 + 19.5V adjustment for + 19.5 ± 0.1 V.

ADJUSTMENTS

5-26. LOG AMPLIFIER LOG AND LINEAR ADJUSTMENT

REFERENCE:

A9, A12, A14, and A15 Schematics

DESCRIPTION

Step attenuators are used to change, in calibrated steps, the input signal level of the spectrum analyzer. The output of Vertical Driver and Blanking Assembly A15 is monitored, and adjustments are performed to calibrate Log Amplifier Assembly A14.

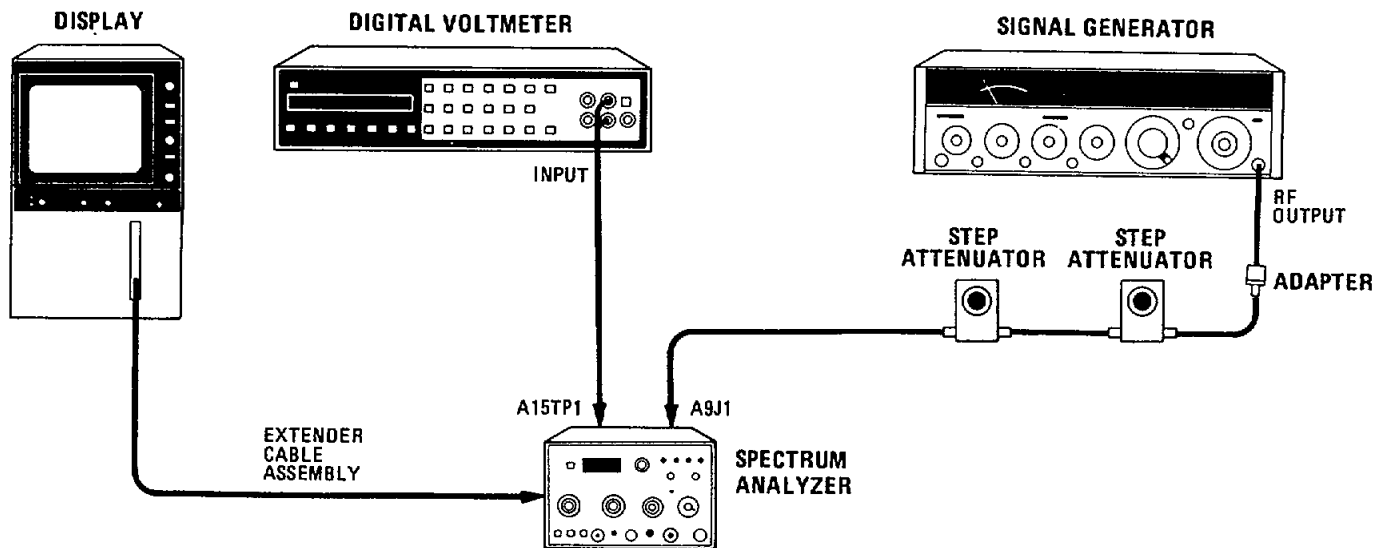

Figure 5-13. Log Amplifier and Linear Adjustment Test Setup

EQUIPMENT

Signal Generator	HP 8640B
Digital Voltmeter.....	HP 3455A
10-dB Step Attenuator	HP 355D, Opt. H82
1-dB Step Attenuator	HP 355C, Opt. H80
Adapter, Type N (m) to SMC (m).....	HP 1250-1023
Adapter, Type N (m) to BNC (f) (2 required)	HP 1250-0780
BNC Cable, 20 cm (9 in).....	HP 18502A
BNC Cable, 120 cm (48 in).....	HP 18503A
Cable Assembly, Banana Plug to Alligator Clip.....	HP 11102A
Test Cable, SMC (f) to BNC (m)	HP 11592-60001
Extender Cable Assembly	HP 5060-0303

ADJUSTMENTS

5-26. LOG AMPLIFIER LOG AND LINEAR ADJUSTMENT (Cont'd)

PROCEDURE

1. Set equipment as follows:

Spectrum Analyzer

FREQ SPAN/DIV 0
 RESOLUTION BW 300 kHz
 INPUT ATTEN 10 dB
 REFERENCE LEVEL -50 dBm
 002: 0 dBmV
 Amplitude Scale LIN
 SWEEP TIME/DIV AUTO
 SWEEP TRIGGER FREE RUN

Digital Voltmeter

RANGE 10
 FUNCTION dcV
 TRIGGER INTERNAL
 MATH OFF
 AUTO CAL ON

2. Connect equipment as shown in Figure 5-13. Set 1-dB step attenuator to 10 dB. Set signal generator frequency to 301.4 MHz and OUTPUT LEVEL to -13 dBm. Remove W7 from A9J1. Connect signal generator output through step attenuators and test cable to A9J 1.

NOTE

The HP 355C 10 dB attenuation is included to compensate for the 10 dB of gain on Step Gain Assembly A12 the TEST-NORM switch is in TEST.

3. Set the TEST-NORM switch on Step Gain Assembly A12 to the TEST position. Tune signal generator frequency for maximum signal amplitude on display with 10 dB step attenuator set to 0 dB. (It may be necessary to reduce signal generator OUTPUT LEVEL slightly.)
4. Disconnect signal generator output from step attenuator. Measure offset at A15TP and record.

_____ mV

5. Connect signal generator to step attenuator and adjust signal generator FINE TUNE control to peak signal on CRT display.
6. Adjust spectrum analyzer REF LEVEL CAL and signal generator OUTPUT LEVEL for DVM reading (± 1 mV) of 800 mV plus offset recorded in step 4, as measured at A15TP1.
7. Set Amplitude Scale to 10 dB/DIV.
8. Set 10-dB step attenuator to 0 dB and adjust A14R23 SLOPE for DVM reading (± 1 mV) of 800 mV plus offset recorded in step 4, as measured at A15TP1.

ADJUSTMENTS

5-26. LOG AMPLIFIER LOG AND LINEAR ADJUSTMENT (Cont'd)

9. Set 10-dB step attenuator to 60 dB and adjust A14R10 OFFSET for DVM reading (± 1 mV) of 200 mV plus offset recorded in step 4, as measured at A15TP1.
10. Repeat steps 8 and 9 until no further adjustment is necessary.
11. Set 10-dB step attenuator to 30 dB and adjust A14R23 SLOPE for DVM reading (± 1 mV) of 500 mV plus offset recorded in step 4, as measured at A15TP1.
12. Set 10-dB step attenuator to 0 dB and adjust A14R69 - 30 dB for DVM (± 1 mV) of 800 mV plus offset recorded in step 4, as measured at A15TP1.
13. Repeat steps 11 and 12 until no further adjustment is necessary.
14. Set 10-dB step attenuator to 10 dB and adjust A14R23 SLOPE for DVM reading (± 1 mV) of 700 mV plus offset recorded in step 4, as measured at A15TP1.
15. Set 10-dB step attenuator to 0 dB and adjust A14R39 - 10 dB for DVM reading (± 1 mV) of 800 mV plus offset recorded in step 4, as measured at A15TP1.
16. Repeat steps 14 and 15 until no further adjustment is necessary.
17. Repeat steps 8 through 16 until limits in Table 5-7 are met.

Table 5- 7. Log Fidelity Check

Step Attenuator Setting (dB)	DVM Reading*
0	Ref: 800 \pm 1 mV
10	700 \pm 3 mV
20	600 \pm 4 mV
30	500 \pm 4 mV
40	400 \pm 5 mV
50	300 \pm 6 mV
60	200 \pm 7 mV
70	100 \pm 8 mV

*Plus offset

Linear Output and Linear Step Gain

18. Set spectrum analyzer controls as follows:

REFERENCE LEVEL..... - 50 dBm
 002: 0 dBmV
 Amplitude Scale.....LIN

ADJUSTMENTS

5-26. LOG AMPLIFIER LOG AND LINEAR ADJUSTMENT (Cont'd)

19. Set 10-dB step attenuator to 0 dB and adjust A14R34 LIN for DVM reading (± 1 mV) of 800 mV plus offset recorded in step 4, as measured at A15TP1.
20. Make adjustments indicated in Table 5-8 .

Table 5-8. Linear Gain Adjustments

Adjustment	Step Attenuator	Reference Level	DVM Reading*
A14R34	0	-50 dBm	Ref: 800 ± 1 mV
A14R33	10	-60 dBm	800 ± 5 mV
A14R30	20	-70 dBm	800 ± 5 mV
A14R27	30	-80 dBm	800 ± 5 mV
No Adjustment	40	-90 dBm	800 ± 10 mV

*Plus offset

Log Gain

21. Set spectrum analyzer control as follows:

REFERENCE LEVEL..... - 50 dBm
 002: 0 dBmV
 Amplitude Scale..... 1 dB/DIV

22. Set 10-dB step attenuator to 0 dB. Adjust signal generator for DVM reading (± 1 mV) of 800 mV plus offset recorded in step 4, as measured at A15TP1.
23. Set 10-dB step attenuator to 40 dB. Set REF LEVEL dBm to -90 and adjust A14R121 LOG GAIN for DVM reading (± 3 mV) of 800 mV plus offset recorded in step 4, as measured at A15TP1.

002: - 40 dBmV

24. Check log gain steps according to Table 5-9.

Table 5-9. Log Gain Adjustment Limits

Step Attenuator	Reference Level	DVM Reading*
0	-50 dBm	Ref: $800 +1$ mV
10	-60 dBm	$800 +30$ mV
20	-70 dBm	$800 +30$ mV
30	-80 dBm	$800 +30$ mV
40	-90 dBm	$800 +30$ mV

*Plus offset

ADJUSTMENTS

5-26. LOG AMPLIFIER LOG AND LINEAR ADJUSTMENT (Cont'd)

Error Check (1 dB/DIV)

25. Set spectrum analyzer controls as follows:

REFERENCE LEVEL..... - 50 dBm
002: 0dBmV
 Amplitude Scale..... 1 dB

26. Set both step attenuators to 0 dB. Reduce signal generator OUTPUT LEVEL until signal appears at top of display. Adjust signal generator FINE TUNE to peak trace on display and adjust OUTPUT LEVEL for DVM reading (± 1 mV) of 800 mV plus offset recorded in step 4, as measured at A 5TP 1. Increase attenuation in 1-dB steps and take DVM readings to check log amplifier output. (Refer to Table 5-10.)

27. Return A12S1 TEST-NORM switch to NORM. Remove test cable and reconnect W7 to A9J1.

Table 5-10. Log Amplifier Output Limits

Step Attenuator	DVM Reading*
1	700 \pm 10 mV
2	600 \pm 20 mV
3	500 \pm 30 mV
4	400 \pm 30 mV
5	300 \pm 30 mV
6	200 \pm 30 mV
7	100 \pm 30 mV
*Plus offset	

ADJUSTMENTS

5-27. SWEEP TIME PER DIVISION ADJUSTMENT

REFERENCE

A8 Schematic

DESCRIPTION

Sweep time per division is adjusted for proper sweep time and 'dead time.'

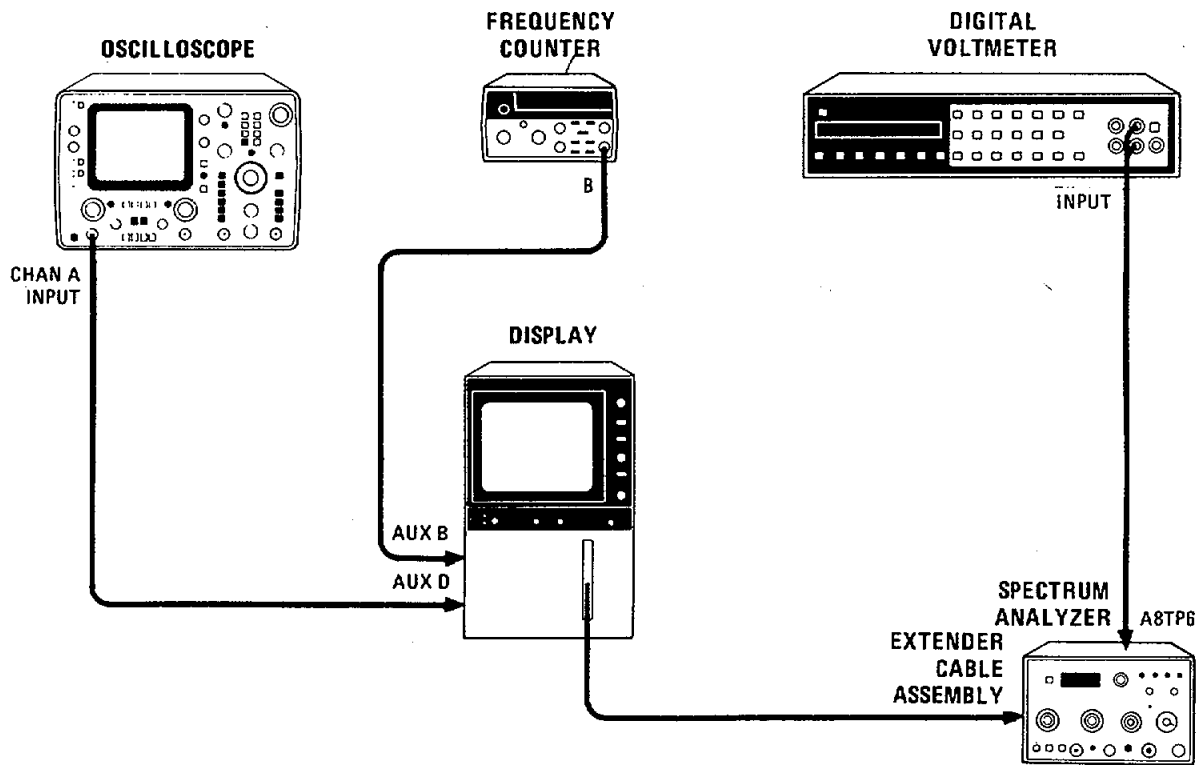

Figure 5-14. Sweep Time Per Division Adjustment Test Setup

EQUIPMENT

Oscilloscope.....	HP 1741A
Digital Voltmeter	HP 3455A
Timer/Counter	HP 5308A
BNC Cable, 120 cm (48 in)	HP 18503A
Cable, Banana Plug to Alligator Clips 150 cm (60 in)	HP 11002A
Extender Cable Assembly	HP 5060-0303

ADJUSTMENTS

5-27. SWEEP TIME PER DIVISION ADJUSTMENT (Cont'd)

PROCEDURE

1. Set equipment as follows:

Oscilloscope

DISPLAY.....A
 TRIGGER.....A
 CHAN A.....2 VOLTS/DIV
 AC-GND-DC.....DC
 WRITE.....ON
 TIME/DIV.....2 mSEC
 MAG X5.....OFF
 EXT TRIGGER.....INT
 MODE.....MAIN

Digital Voltmeter

RANGE.....AUTO
 FUNCTION.....dcV
 AUTO CAL.....ON
 TRIGGER.....INTERNAL
 MATH.....OFF

TIMER/COUNTER

TIME BASE.....10 μ s
 FUNCTION.....PER B

2. Connect equipment as shown in Figure 5-14. Connect oscilloscope to AUX D, HORIZONTAL OUT- PUT, rear of display mainframe, or to A8TP5 of HP 8558B. Connect digital voltmeter to A8TP6 (located to the left and below A8TP4.)
3. Adjust A8R7 + 10IOV adjustment for 10V 40.02 V.

NOTE

The + 10V must be adjusted while analyzer is still cold, during first five minutes after turn-on. If instrument has been operating, turn off mainframe and remove A8 Sweep Generator assembly. Let A8 assembly cool on bench for 15 minutes. Replace A8 and proceed with adjustment of A8R7 during the first five minutes after turn on.

4. Set spectrum analyzer controls as follows:

SWEEP TIME/DIV.....1 ms
 SWEEP TRIGGER.....FREE RUN

5. Check oscilloscope trace for approximately a - 5V to + 5V ramp.

ADJUSTMENTS

5-27. SWEEP TIME PER DIVISION ADJUSTMENT (Cont'd)

6. Adjust A8R10 1 ms adjustment for a 10 ms ramp time. Measure dead time of ramp.

MIN.	ACTUAL	MAX.
0.25 ms	_____	0.40 ms

7. Set spectrum analyzer SWEEP TIME/DIV to 2 mSEC. Adjust A8R13 2 ms adjustment for a 20 ms ramp time. Measure dead time of ramp.

MIN.	ACTUAL	MAX.
6.0 ms	_____	9.0 ms

8. Set SWEEP TIME/DIV to 1 mSEC. Frequency counter should read sweep time plus dead time (10 ms + dead time 40.05 ms). Adjust A8R10 if necessary to obtain an indication of 10 ms + dead time ± 0.05 ms.

9. Set SWEEP TIME/DIV to 2 mSEC. Frequency counter should read sweep time plus dead time (20 ms + dead time -0.10 ms). Adjust A8R13 if necessary to obtain an indication of 20 ms + dead time ± 0.10 ms.

10. Repeat steps 8 and 9 until the sweep time plus dead time (dt) for the 1 ms and 2 ms sweeps are within limits.

MIN	ACTUAL	MAX.
10 ms + dt - 0.05 ms	_____	10 ms + dt + 0.05 ms
20ms + dt- 0.10ms	_____	20ms + dt + 0.10ms

ADJUSTMENTS

5-28. FREQUENCY CONTROL AND DPM ADJUSTMENTS

REFERENCE

A1 and A7 Schematics

DESCRIPTION

The + 14.5V and REF V voltages are adjusted and the - 10.0V voltage is checked. The frequency limits and linearity of the YIG oscillator are set. The FREQUENCY MHz readout is adjusted for proper voltage calibration and for correct ranging.

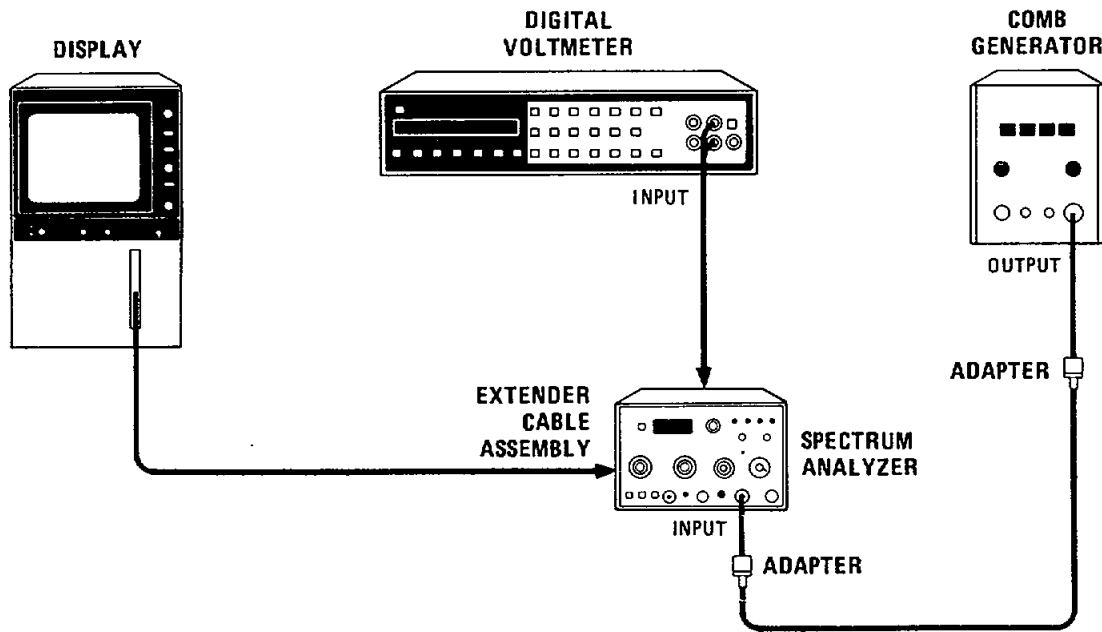

Figure 5-15. Frequency Control and DPM Adjustments Test Setup

EQUIPMENT

Digital Voltmeter	HP 3455A
Comb Generator	HP 8406A
Adapter, Type N (m) to BNC (f) (2 required).....	HP 1250-0780
BNC Cable, 120 cm (48 in)	HP 18503A
Cable, Banana Plug to Alligator Clips 150 cm (60 in)	HP 11002A
Extender Cable Assembly	HP 5060-0303

Additional Equipment, Options 001 and 002:

Minimum Loss Adapter, 75Ω to 50Ω.....	HP 08558-60031
Adapter, BNC (m) to BNC (m), 75Ω	HP 1250-1288
Adapter, SMA (f) to SMA (f)	HP 1250-1158
Adapter, BNC (f) to SMA (m).....	HP 1250-1200

ADJUSTMENTS

5-28. FREQUENCY CONTROL AND DPM ADJUSTMENTS (Cont'd)

PROCEDURE

Voltage Adjustments

1. Connect equipment as shown in Figure 5-15. Connect digital voltmeter to A7TP7 (located between A7R4 REF V and A7R5 + 14.5V adjustments).
2. Adjust A7R5 + 14.5V potentiometer for $+ 14.50 \pm 0.02$ V.
3. Connect digital voltmeter to A7TP8 (located to the right of A7R5 + 14.5V adjustment) and check for -10.0 ± 0.2 V.
4. Connect digital voltmeter to A7TP6 and adjust A7R4 REF V potentiometer for $+ 6.00 \pm 0.01$ V.

YIG Oscillator Adjustment

NOTE

Check HORIZ GAIN and HORIZ POSN adjustments and perform voltage adjustments before continuing with the following procedure.

5. Set spectrum analyzer controls as follows:

START - CENTER	CENTER
FREQ SPAN/DIV	5 MHz
RESOLUTION BW	100 kHz
INPUT ATTEN	dB
REFERENCE LEVEL	-10 dBm
002: +40dBmV	
Amplitude Scale	10 dB/DIV
SWEEP TIME/DIV	AUTO
SWEEP TRIGGER	FREE RUN

6. Turn FREQUENCY ZERO control fully counterclockwise.
7. Adjust TUNING for FREQUENCY MHz readout of approximately - 16.0.

NOTE

Press FREQUENCY CAL button to remove YIG oscillator hysteresis whenever the TUNING control is adjusted.

8. Adjust A7R3 2.0 GHZ to center LO feedthrough (within one division) on CRT.

NOTE

Disconnect comb generator whenever it is necessary to center the LO feedthrough.

ADJUSTMENTS

5-28. FREQUENCY CONTROL AND DPM ADJUSTMENTS (Cont'd)

9. Couple FREQ SPAN/DIV and RESOLUTION BW controls. Set FREQ SPAN/DIV to 100 MHz/DIV. Set comb generator frequency to 100 MHz. Adjust TUNING to approximately 500 MHz for full-screen display of comb teeth.
10. Adjust TUNING, A7R1 3.55 GHZ, and A7R2 3.55 FINE to align comb teeth on vertical graticule lines (one tooth per division).
11. Repeat steps 7 and 8. (A7R1 3.55 GHZ adjustment has a slight effect on A7R3 2.0 GHZ adjustment.)
12. Set FREQ SPAN/DIV to 1 MHz and comb generator frequency to 1 MHz.
13. Adjust TUNING to approximately 750 MHz. Adjust A7R6 FM to align comb teeth on vertical graticule lines (one tooth per division).

Digital Panel Meter Adjustment

14. Set FREQ SPAN/DIV to 500 kHz.
15. Center LO feedthrough. Press FREQUENCY CAL button and re-center LO feedthrough.
16. Adjust FREQUENCY ZERO control for FREQUENCY MHz readout of 00.0.
17. Set comb generator frequency to 100 MHz. Adjust TUNING to center 1500-MHz tooth (15th tooth from LO feedthrough). Press FREQUENCY CAL button and re-center comb tooth. Adjust A1A2R3 REF for FREQUENCY MHz readout of 1500 + 1.
18. Adjust A7R8 RNG fully clockwise. Set comb generator frequency to 10 MHz. Adjust TUNING to center 190-MHz comb tooth (19th tooth from LO feedthrough). Adjust A7R7 GAIN for FREQUENCY MHz readout of 190.0.

NOTE

Press FREQUENCY CAL frequently while counting the comb teeth to avoid miscounting.

19. Adjust TUNING for FREQUENCY MHz readout of 198.5. Slowly adjust A7R8 RNG counterclockwise until range switches (no decimal on FREQUENCY MHz display).
20. Center LO feedthrough. Press FREQUENCY CAL button and re-center LO feedthrough. Set comb generator frequency to 100 MHz. Adjust TUNING to center 200-MHz comb tooth (second tooth from LO feedthrough). Press FREQUENCY CAL button and re-center comb tooth. Adjust A7R72 OFS for FREQUENCY MHz readout of 200.
21. Repeat steps 15 through 21 until 190.0 MHz, 200 MHz, and 1500 MHz readouts on FREQUENCY MHz display are calibrated.

ADJUSTMENTS

5-29. 1 dB OFFSET ADJUSTMENT

REFERENCE

A15 Schematic

DESCRIPTION

Reference is set in 10 dB/DIV and 1 dB offset is adjusted in 1 dB/DIV for the same full display reference in 10 dB/DIV.

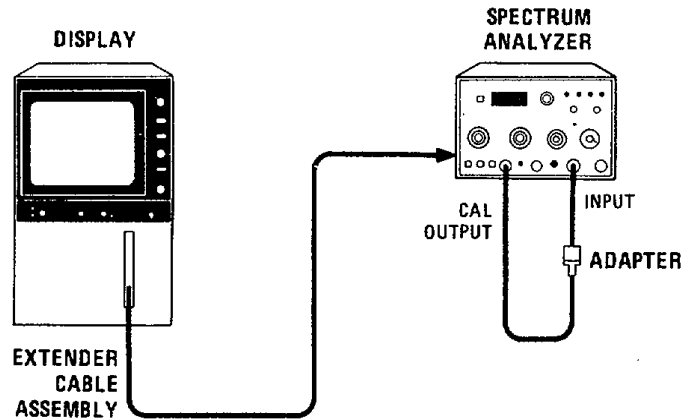

Figure 5-16. 1-dB Offset Adjustment Test Setup

EQUIPMENT

BNC Cable, 120 cm (9 in)	HP 18502A
Adapter, Type N (m) to BNC (f)	HP 1250-0780
Extender Cable Assembly	HP 5060-0303

Additional Equipment, Options 001 and 002:

BNC Cable, 30 cm (12 in)	HP 11652-60012
--------------------------------	----------------

PROCEDURE

1. Set Spectrum Analyzer controls as follows:

START - CENTER	CENTER
TUNING	280 MHz
FREQ SPAN/DIV	1 MHz
RESOLUTION BW	1 MHz
INPUT ATTEN	10 dB
REFERENCE LEVEL	-20 dBm
002: +30dBmV	
REF LEVEL FINE	Approximately - 10
Amplitude Scale	LIN
SWEEP TIME/DIV	AUTO
SWEEP TRIGGER	FREE RUN

ADJUSTMENTS

5-29. 1-dB OFFSET ADJUSTMENT (Cont'd)

2. Connect equipment as shown in Figure 5-16.
3. Set Amplitude Scale switch to LIN. Set TUNING control to center the trace on the display. Set REF LEVEL FINE for a full-screen trace (signal at top graticule line).
4. Set Amplitude Scale switch to 10 dB/DIV. Adjust VERTICAL GAIN if necessary for full screen trace.
5. Repeat steps 3 and 4 until the trace is full screen in both LIN and 10 dB/DIV.

NOTE

1 dB/DIV will read approximately 0.5 dB (0.5 division) low when using extender cable assembly. Adjusting A15R1 1 dB OFFSET for a trace 0.5 division down from top graticule line should place signal at top graticule line when 8558B is properly installed in 180-series mainframe.

6. Amplitude Scale switch to 1 dB/DIV. Adjust A15R1 1 dB OFFSET for a trace 0.5 division down from top graticule line.
-

THIS PAGE MISSING NOT AVAILABLE FOR DIGITIZATION.

PAGES
5-53 through 5-59

SECTION VI. REPLACEABLE PARTS

6-1. INTRODUCTION

6-2. This section contains information for ordering replacement parts. Table 6-1 includes a list of reference designations and a list of abbreviations used in the parts list. Table 6-2 lists names and addresses that correspond to the manufacturer code numbers in the parts list. Table 6-3 lists all replaceable parts in alpha-numerical order by reference designation.

6-3. REPLACEABLE PARTS LIST

6-4. Table 6-3, the list of replaceable parts, is organized as follows:

1. Electrical assemblies and their components in alpha-numerical order by reference designation
2. Miscellaneous parts, with appropriate electrical assembly
3. Chassis-mounted electrical parts, in alphanumerical order by reference designation
4. Mechanical chassis parts, at end of parts list

6-5. The following information is listed for each part:

1. The Hewlett-Packard part number
2. The part number check digit (CD)
3. The total quantity (Qty) in the instrument. This quantity is given only once, at the first appearance of the part in the list.
4. The description of the part
5. A five-digit code indicating a typical manufacturer of the part
6. The manufacturer's part number

6-6. ORDERING INFORMATION

6-7. To order a part listed in the replaceable parts table, quote the Hewlett-Packard part number (with check digit), indicate the quantity required, and address the order to the nearest Hewlett-Packard office. The check digit will ensure accurate and timely processing of your order.

6-8. To order a part that is not listed in the replaceable parts table, include the instrument model number, instrument serial number, the description and function of the part, and the number of parts required. Address the order to the nearest Hewlett-Packard office.

Table 6-1. Reference Designations and Abbreviations (1 of 3)

REFERENCE DESIGNATIONS

A.....Assembly
 AT..... Attenuator, Isolator, Limiter, Termination
 B.....Fan, Motor
 BT.....Battery
 C.....Capacitor
 CP.....Coupler
 CR.....Diode, Diode Thyristor, Step Recovery Diode (SCR), Varactor
 DC.....Directional Coupler
 DL.....Delay Line
 DS.....Annunciator, Lamp, Light Emitting Diode (LED), Signaling Device (Audible or Visible)
 E.....Miscellaneous Electrical Part

F.....Fuse
 FL.....Filter
 H.....Hardware
 HY.....Circulator
 J.....Electrical Connector (Stationary Portion), Jack
 K.....Relay
 L.....Coil, Inductor
 M.....Meter
 MP.....Miscellaneous Mechanical Part
 P.....Electrical Connector (Movable Portion), Plug
 Q.....Silicon Controlled Rectifier (SCR), Transistor, Triode Thyristor
 R.....Resistor

RT.....Thermistor
 S.....Switch
 T.....Transformer
 TB.....Terminal Board
 TC.....Thermocouple
 TP.....Test Point
 U.....Integrated Circuit, Microcircuit
 V.....Electron Tube
 VR.....Breakdown Diode(Zener), Voltage Regulator
 W.....Cable, Transmission Path, wire
 X.....Socket
 Y.....Crystal Unit (Piezoelectric, Quartz)
 Z.....Tuned Cavity, Tuned Circuit

ABBREVIATIONS

A

A.....Across Flats, Acrylic, Air (Dry Method), Ampere
 ADJ.....Adjust, Adjustment
 ANSI.....American National Standards Institute (formerly USASI-ASA)
 ASSY.....Assembly
 AWG.....American Wire Gage

B

BCD.....Binary Coded Decimal
 BD.....Deep, Depth, Diametric
 BE-CU.....Beryllium Copper
 BNC.....Type of Connector
 BRG.....Bearing, Boring
 BRS.....Brass
 BSC.....Basic
 BTN.....Button

C

C.....Capacitance, Capacitore, Center Tapped, Centistoke, Cermet, Circular Mil Foot, Closed Cup, Cold, Compression
 CCP.....Carbon Composition Plastic
 CD.....Cadmium, Card, Cold-Drawn, Cord
 CER.....Ceramic
 CHAM.....Chamfer
 CHAR.....Character, Characteristic, Charcoal
 CMOS.....Complementary Metal Oxide Semiconductor
 CNDCT.....Conducting, Conductive, Conductivity, Conductor
 CONT.....Contact, Continuous, Control, Controller
 CONV.....Converter
 CPRSN.....Compression
 CUP-PT.....Cup Point
 CW.....Clockwise, Continuous Wave

D

D.....Deep, Depletion, Depth, Diameter, Direct Current
 DA.....Darlington
 DAP-GL.....Diallyl Phthalate Glass
 DBL.....Double
 DCDR.....Decoder
 DEG.....Degree
 D-HOLE.....D-Shaped Hole
 DIA.....Diameter
 DIP.....Dual In-Line Package
 DIP-SLDR.....Dip Solder
 D-MODE.....Depletion Mode
 DO.....Package Type Designation
 DP.....Deep, Depth, Diametric Pitch, Dip
 DP3TMINTR.....Double Pole Three Throw, Miniature
 DPDTMINTR.....Double Pole Double Throw, Miniature
 DWL.....Dowel

E

E-R.....E-Ring
 EXT.....Extended, Extension, External, Extinguish

F

F.....Fahrenheit, Farad, Female, Film (Resistor), Fixed, Flange, Flint, Fluorine, Frequency
 FC.....Carbon Film / Composition, Edge of Cutoff Frequency, Face
 FDTHRU.....Feed Through
 FEM.....Female
 FIL-HD.....Fillister Head
 FL.....Flash, Flat, Fluid
 FLAT-PT.....Flat Point
 FR.....Front
 FREQ.....Frequency
 FT.....Current Gain Bandwidth Product (Transition Frequency); Feet, Foot
 FXD.....Fixed

G

GEN.....General, Generator
 GND.....Ground
 GP.....General Purpose, Group

H

H.....Henry, Hermaphrodite, High, Hole Diameter, Hot, Hub Inside Diameter, Hydrogen
 HDW.....Hardware
 HEX.....Hexadecimal, Hexagon, Hexagonal
 HLCL.....Helical
 HP.....Hewlett-Packard Company, High Pass, Horsepower

I

IC.....Collector Current, Integrated Circuit
 ID.....Identification, Inside Diameter
 IF.....Forward Current, Intermediate Frequency
 IN.....Inch, indium

INCL.....Including
 INT.....Integral, Intensity, Internal
 INTL.....Internal, International

J

J-FET.....Junction Field Effect Transistor
 JFET.....Junction Field Effect Transistor

K

K.....Kelvin, Key, Kilo, Potassium
 KNRLD.....Knurled
 KVDC.....Kilovolts Direct Current

Table 6-1. Reference Designations and Abbreviations (2 of 3)

<p>L</p> <p>LED..... Light Emitting Diode LG..... Length, Long LIN..... Linear, Linear Taper, Linearity LK..... Link, Lock LKG..... Leakage, Locking LOGO..... Logotype LUM..... Luminous</p> <p>M</p> <p>M..... Male, Maximum, Mega, Mil, Milli, Mode, Momentary, Mounting Hole Centers, Mounting Tapping Hole Diameter MA..... Milliampere MACH..... Machined MAX..... Maximum MC..... Hot Molded Carbon Composition, Megacycle, Microcircuit, Molded Carbon Composition MET..... Metal, Metallic, Metallized, Metallurgical MHZ..... Megahertz MIT..... Miter MLD..... Mold, Molded MM..... Magnetized Material (Restricted Articles Code); Millimeter MOM..... Momentary MTG..... Mounting MTLC..... Metallic MUW..... Music Wire MW..... Milliwatt</p> <p>N</p> <p>N..... Fan Out, Intrinsic Stand Off Ratio, Nano, Nanosecond, Nitrogen, None N-CHAN..... N-Channel NH..... Nanohenry NMH..... Nanometer Nonmetallic NO..... Normally Open, Number NOM..... Nominal NPN..... Negative Positive Negative (Transistor) NS..... Nanosecond, Non-Shorting, Nose NUM..... Numeric, Numerical NYL..... Nylon (Polyamide)</p> <p>O</p> <p>OA..... Other Restricted Articles, Group A (Restricted Articles Code); Over-All OD..... Olive Drab, Outside Diameter OP AMP..... Operational Amplifier OPT..... Optical, Option, Optional</p> <p>P</p> <p>PA..... Picoampere, Power Amplifier, Pressure Angle, Protactinium</p>	<p>PAN-HD..... Pan Head PAR..... Parallel, Parity PB..... Lead (Metal), Push Button PC..... Picocoulomb, Piece, Printed Circuit PCB..... Printed Circuit Board P-CHAN..... P-Channel PD..... Pad, Palladium, Pitch Diameter, Power Dissipation PF..... Picofarad; Pipe, Female Connection; Power Factor PKG..... Package PLSTC..... Plastic PNL..... Panel PNP Positive (Transistor) POLYC..... Polycarbonate POLYE..... Polyester POT..... Potentiometer POZI..... Pozidriv Recess PREC..... Precision PRP..... Purple, Purpose PSTN..... Piston PT..... Part, Pint, Platinum, Point, Pulse Time PW..... Power Wirewound, Pulse Width</p> <p>Q</p> <p>Q..... Figure of Merit</p> <p>R</p> <p>R..... Range, Red, Resistance, Resistor, Right, Ring, Rosin, Rubber-Resin, Run Torque REF..... Reference RES..... Research, Resistance, Resistor RF..... Radio Frequency RGD..... Rigid RND..... Round RR..... Rear RVT..... Rivet, Riveted</p> <p>S</p> <p>SAWR..... Surface Acoustic Wave Resonator SEG..... Segment SGL..... Single SI..... Silicon, Square Inch SL..... Slide, Slow SLT..... Slate, Slot, Slotted SMA..... Subminiature, A Type (Threaded Connector) SMC..... Subminiature, C Type (Threaded Connector) SPCTG..... Spacing SPDTSUBMIN..... Single Pole Double Throw, Subminiature SPST..... Single Pole Single Throw SQ..... Square SST..... Stainless Steel STL..... Steel SZ..... Size</p>	<p>T</p> <p>T..... Tab Width, Taper, Teeth, Temperature, Tera, Tesla, Thermoplastic (Insulation), Thickness, Time, Timed, Tooth, Turns Ratio, Typical TA..... Ambient Temperature, Tantalum TC..... Thermoplastic THD..... Thread, Threaded THK..... Thick TO..... Package Type Designation, Troy Ounce Positive Negative..... TPG TR-HD..... Truss Head TRMR..... Trimmer TRN..... Turn, Turns TRSN..... Torsion</p> <p>U</p> <p>UCD..... Microcandela UF..... Microfarad UH..... Microhenry UL..... Microliter, Underwriters' Laboratories, Inc. UNHDND..... Unhardened</p> <p>V</p> <p>V..... Vanadium, Variable, Violet, Volt, Voltage VAC..... Vacuum; Volts, Alternating Current VAC/DC..... Volts, Alternating and Direct Current VAR..... Variable VDC..... Volts, Direct Current</p> <p>W</p> <p>W..... Watt, Wattage, White, Wide, Width, Wire W/CP..... Wire / Conductive Plastic W/SW..... With Switch WW..... Wire Wound</p> <p>X</p> <p>X..... By (Used With Dimensions), Reactance XSTR..... Transistor</p> <p>Y</p> <p>YIG..... Yttrium-iron-Garnet</p> <p>Z</p> <p>ZNR..... Zener</p>
---	---	---

Table 6-1. Reference Designations and Abbreviations (3 of 3)

MULTIPLIERS		
Abbreviation	Prefix	Multiple
T	tera	10 ¹²
G	giga	10 ⁹
M	mega	10 ⁶
k	kilo	10 ³
da	deka	10
d	deci	10 ⁻¹
c	centi	10 ⁻²
m	milli	10 ⁻³
,U	micro	10 ⁻⁶
n	nano	10 ⁻⁹
p	pico	10 ⁻¹²
f	femto	10 ⁻¹⁵
a	atto	10 ⁻¹⁸

Table 6-2. Manufacturers Code List

Mfr. No.	Manufacturer Name	Address	Zip Codes
00000	ANY SATISFACTORY SUPPLIER		
01121	ALLEN-BRADLEY CO	MILWAUKEE, WI	53204
01295	TEXAS INSTR INC SEMICOND CMPNT DIV	DALLAS, TX	75222
02111	SPECTROL ELECTRONICS CORP	CITY OF IND, CA	91745
02660	BUNKER RAMO CORP AMPHENOL CONN DIV	BROADVILLE, IL	60153
03888	K D I PYROFILM CORP	WHIPPANY, NJ	07981
04713	MOTOROLA SEMICONDUCTOR PRODUCTS	PHOENIX, AZ	85008
06665	PRECISION MONOLITHICS INC	SANTA CLARA, CA	95050
11236	CTS OF BERNE INC	BERNE, IN	46711
13606	SPRAGUE ELECT CO SEMICONDUCTOR DIV	CONCORD, NH	03301
18736	VOLTRONICS CORP	HANOVER, NJ	07936
19701	MEPCO/ELECTRA CORP	MINERAL WELLS; TX	76067
24046	TRANSITRON ELECTRONIC CORP	WAKEFIELD, MA	01880
24546	CORNING GLASS WORKS (BRADFORD)	BRADFORD, PA	16701
28480	HEWLETT-PACKARD CO CORPORATE HQ	PALO ALTO, CA	94304
3L585	RCA CORP SOLID STATE DIV	SOMERVILLE, NJ	
30983	MEPCO/ELECTRIC CORP	SAN DIEGO, CA	92121
33095	SPECTRUM CONTROL INC	FAIRVIEW, PA	16415
52763	STETTNER-TRUSH INC	CAZENOVIA, NY	13035
56289	SPRAGUE ELECTRIC CO	NORTH ADAMS, MA	01247
71041	BOSTON GEAR WKS DIV OF NA ROCKWELL	QUINCY, MA	02171
72136	ELECTRO MOTIVE CORP	FLORENCE, SC	06226
72982	ERIE TECHNOLOGICAL PRODUCTS INC	ERIE, PA	16512
74970	JOHNSON E F CO	WASECA, MN	56093
78707	TEK BEARING CO INC	NEW YORK, NY	10013
9N171	UNITRODE COMPUTER PRODUCTS CORP	METHUEN, MA	
92830	ASSOCIATED SPRING CORP	BRISTOL, CT	06010

Table 6-3. Replaceable Parts

Reference Designation	HP Part Number	C D	Qty	Description	Mfr. Code	Mfr Part Number
A1 A1A1 A1A2	08558-60125	1	1	DIGITAL PANEL METER ASSEMBLY NOT ASSIGNED DPM DRIVER ASSEMBLY NOTE	28480	08558-60125
				SEE A2 FOR DPM DISPLAY		
A1A2C1 THRU A1A2C3 A1A2C4 A1A2C5 THRU A1A2C9	0180-0197	8	18	NOT ASSIGNED CAPACITOR-FXD 2.2UF+-10% 20VDC TA	56289	150D225X9020A2
A1A2C10 A1A2C11 A1A2C12 A1A2C13 A1A2C14 A1A2C15 A1A2C16 A1A2CR1 A1A2CR2 A1A2CR3	0160-4084 0160-4084 0180-0197 0160-0168 0180-2207 0160-4084 1901-0040 1901-0050	8 8 8 1 5 8 1 1 3	11	NOT ASSIGNED CAPACITOR-FXD .1UF +-20% 50VDC CER CAPACITOR-FXD .1UF +-20% 50VDC CER CAPACITOR-FXD 2.2UF+-10% 20VDC TA NOT ASSIGNED CAPACITOR-FXD .1UF +-10% 200VDC POLYE CAPACITOR-FXD 100UF +-10% 10VDC TA CAPACITOR-FXD , 1UF +-20X 50VDC CER NOT ASSIGNED DIODE-SWITCHING 30V 50MA 2NS DO-35 DIODE-SWITCHING 80V 200MA 2NS DO-35	28480 28480 56289 28480 56289 28480 28480 28480	0160-4084 0160-4084 150D225X9020A2 0160-0168 150D107X9010R2 0160-4084 1901-0040 1901-0050
A1A2J1	1200-0508	0	1	SOCKET-IC 14-CONT DIP-SLDR	28480	1200-0508
A1A2L1	9100-1644	3	1	INDUCTOR RF-CH-MLD 330UH 5% .2DX.45L.G	28480	9100-1644
A1A2Q1 A1A2Q2 A1A2Q3 A1A2Q4	1854-0404 1854-0404	0 0	35	NOT ASSIGNED NOT ASSIGNED TRANSISTOR NPN SI TO-18 PD=360MW TRANSISTOR NPN SI TO-18 PD=360MW	28480 28480	1854-0404 1854-0404
A1A2R1 A1A2R2 A1A2R3 A1A2R4 A1A2R5	0757-0465 0757-0420 2100-1702 0698-3446 0757-0442	6 3 7 3 9	27	RESISTOR 100K 1% .125W F TC=0+-100 RESISTOR 750 1% .125W F TC=0+-100 RESISTOR-TRMR 100 10% WW SIDE-ADJ 20-TRN RESISTOR 383 1% .125W F TC=0+-100 RESISTOR 10K 1X .125W F TC=0+-100	24546 24546 02660 24546 24546	C4-1/8-TO-1003-F C4-1/8-TO-751-F 3810P-101 C4-1/8-TO-383R-.F C4-1/8-TO-1002-F
A1A2R6 A1A2R7 A1A2R8 A1A2R9 A1A2R10	0698-3260 0698-3457 0698-3439 0757-0442 0757-0416	9 6 4 9 7	5	RESISTOR 464K 1% .125W F TC=0+-100 RESISTOR 316K 1% .125W F TC=0+-100 RESISTOR 178 1% .125W F TC=0+-100 RESISTOR 100K 1%X 125W F TC=0+-100 RESISTOR 511 1% .125W F TC=0+-100	28480 28480 24546 24546 24546	0698-3260 0698-3457 C4-1/8-TO-178R-F C4-1/8-TO-1002-F C4-1/8-TO-511R-F
A1A2R11 A1A2R12 A1A2R13 A1A2R14 A1A2TP1 A1A2TP2 A1A2TP3	0757-0442 0757-0458 0757-0458 0757-0317 0360-0535 0360-0535 0360-0535	9 7 7 7 0 0 0	13	RESISTOR 10K 1% .125W F TC=0+-100 RESISTOR 51.1K 1% .125W F TC=0+-000 RESISTOR 51.1K 1X .125W F TC=0+-100 RESISTOR 1.33K 1% .125W F TC=0+-100 TERMINAL TEST POINT PCB TERMINAL TEST POINT PCB TERMINAL TEST POINT PCB	24546 24546 24546 24546 00000 00000 00000	C4-1/8-TO-1002-F C4-1/B-TO-5112-F C4-1/8-TO-5112-F C4--1/8-TO-1331-F ORDER BY DESCRIPTION ORDER BY DESCRIPTION ORDER BY DESCRIPTION
A1A2U1 A1A2U2 A1A2U3 A1A2U4	1826-0431 1858-0047 1820-1413 1810-0346	4 5 2 7	1	IC CONV 24-DIP- C PKG TRANSISTOR ARRAY 16-PIN PLSTC DIP IC DCDR CMOS BCD-TO-7-SEG 4-TO-7-LINE NETWORK-RES 16-DIP080.0 OHM X S	04713 13606 3L585 11236	MC14433L ULN-2003A CD45118E 761-3-RI80
A1A2VR1 A1A2VR2	1902-0064	1	2	NOT ASSIGNED DIODE-ZNR 7.5V 5% DO-35 PD=,4W TC=+.05X	28480	1902-0064
A2	08558-60100	2	1	FRONT SWITCH ASSEMBLY (ELECTRICAL PARTS) NOTE SEE FIGURE 6-3 FOR COMPLETE IDENT- IFICATION OF FRONT SW. ASSY PARTS.	28480	0855860100
A2R1 A2R2 A2R3 A2R4 A2R5 A2R6 A2S1 A2S2	2100-3593 2100-.3452 2100-3066 2100-0542 2100-3973 2100-3973 3101-0044 2100-3973	8 8 0 1 8 8 1 8	1	RESISTOR-VAR PREC W/CP 10-TRN 5K 10% (COARSE TUNE) RESISTOR-VAR PREC W/CP 10-.TRN 10K 10% (FINE TUNE) RESISTOR-VAR PREC WW 10-TRN 5K 5% (FREQ. ZERO) RESISTOR-VAR CONTROL WW 10K 5% LIN (RF LVL FINE) RESISTOR-VARIABLE W/SW 50K +-20%; 10CW (VIDEO FILTER) RESISTOR-VARIABLE W/SW 50K +-20%; 10CW (VIDEO FILTER) SWITCH-PB SPST-NO MOM .5A 115VAC RED-BTN (FREQ. CAL) RESISTOR-VARIABLE W/SW 50K +-20%; 10CW P/O A2RS/R6/52(MAX VIDEO FILTER)	28480 28480 28480 28480 28480 28480 28480 28480	2100-3593 2100-3452 2100-3066 2100-0542 2100-3973 2100-3973 3101-0044 2100-3973

See introduction to this section for ordering information

*Indicates factory selected value

Table 6-3. Replaceable Parts

Reference Designation	HP Part Number	C D	Qty	Description	Mfr. Code	Mfr Part Number
A2A1	08558-60160	4	1	SWITCH BOARD ASSEMBLY	28480	08558-60160
A2A1CR1	1901-0025	2	1	DIODE-GEN PRP 100V 200MA DO-7	28480	1901-0025
A2A1CR2	1902-0064	1		DIODE-ZNR 7.5V 5% ODO-35 PD=.4W TC=+.05%	20480	1902-0064
A2A1DS1	1990-0619	7	8	DISPLAY-NUM-SEG 1-CHAR .3-H	20480	1990-0619
A2A1DS2	1990-0619	7		DISPLAY-NUM-SEG 1-CHAR .3-H	28480	1990-0619
A2A1DS3	1990-0619	7		DISPLAY-NUM-SEG 1-CHAR .3-H	28480	1990-0619
A2A1DS4	1990-0619	7		DISPLAY-NUM-SEG 1-CHAR .3-H	28480	1990-0619
A2A1D55	1990-0485	5	2	LED-LAMP LUM-INT=800UCD IF=30MA-MAX	28480	1990-0485
A2A1R1	0757-0447	4	6	RESISTOR 16.2K 1% .125W F TC=0+-100	24546	C4-1/8-TO-1622-F
A2A1R2	2100-3340	3	1	RESISTOR-VAR CONTROL CCP 1K 20% LIN	28480	2100-3340
A2A1R3	2100-2681	3	1	RESISTOR-TRMR 5K 10% CCP TOP-ADJ I-TRN	28480	2100-2681
A21AR4	2100-3332	3	0	RESISTOR-TRMR 10K 20% CC TOP-ADS 1-TRN	28480	2100-3332
A2A1R5	0757-0444	1	17	RESISTOR 12.1K 1% .125W F TC=0+-100	24546	C4-1/8-TO-1212-F
A2A1R6	2100-1412	6	1	RESISTOR-TRMR 500 20% CCP TOP-ADJ 1-TRN	28480	2100-1412
A2A1R7	2100-3331	2	1	RESISTOR-TRMR 10K 20% MC TOP-ADJ 1-TRN	28480	2100-3331
A2A1R8	0757-0317	7		RESISTOR 1.33K 1% .125W F TC=0+-100	24546	C4-1/8-TO-1331-F
A2A1S1				(REF LEVEL DOM) SEE FIGURE 6-3.		
A2A1S2	3101-2213	0	1	SWITCH-PB DPDT (AMPLITUDE SCALE)	28480	3101-2213
A2A1S3				(SWEEP TIME/DIV) SEE FIGURE 6-3.		
A2A1S4				(SWEEP TRIGGER) SEE FIGURE 6-3.		
A2A1S5				(RESOLUTION BW) SEE FIGURE 6-3.		
A2A1S6				(FREQ SPAN/DIV) SEE FIGURE 6-3.		
A2A1S7	3101-2124	2	1	SWITCH-PB DPDT (START/CENTER)	28480	3101-2124
A21AW1	018558-60168	2	1	RIBBON CABLE ASSY-DPM	28480	08558-60168
A2A1W2	08558-60037	4	1	RIBBON CABLE ASSY-INTERCONNECT	28480	08558-60037
A2A1XDS1	1990-0619	7		DISPLAY-NUM-SEG 1-CHAR .3-H	28480	1990-0819
A2A1XDS2	1990-0619	7		DISPLAY-NUM-SEG I-CHAR .3-H	28480	1990-0619
A2A1XDS3	1990-0619	7		DISPLAY-HUM-SEC I-CHAR .3-H	28480	1990-0619
A2A1XDS4	1990-0619	7		DISPLAY-NUM-SEG 1-CHAR .3-H	28480	1990-0619
A2A1XDS5	1990-0485	5		LED-LAMP LUM-INT=800UCD IF=30MA-MAX	28480	1990-0485
A3	5086-7363	9	1	INPUT ATTENUATOR	28480	5086-7363
	08495-60004	9		RESTORED 08558-60003, EXCHANGE REQUIRED	28480	08495-60004
A4	08558-60004	5	1	FIRST CONVERTER	28480	08558-60004
A4J1	1250-1020	8	4	CONNECTOR-RF SMA FEM SGL-HOLE-RR 50-OHM	28480	1250-1020
A4J2	1250-1020	8		CONNECTOR-RF SMA FEM SGL-HOLE-RR 50-OHM	28480	1250-1020
A4J3	1250--1020	8		CONNECTOR-RF SMA FEM SGL-HOLE-RR 50-OHM	28480	1250-1020
A4J4	1250-1020	8		CONNECTOR-RF SMA FEM SGL-HOLE-RR 50-OHM	28480	1250-1020
A4MP1	0E8558-00052	7	1	GASKET, FIRST CONVERTER	28480	08558-00052
A4HP2	08558--20042	7	1	COVER, FIRST CONVERTER	28480	08558-20042
A4MP3	08558-20043	8	1	MOUNT, FIRST CONVERTER	28480	08558-20043
A4R0	0698-7212	9	3	RESISTOR 100 1% .05W F TC=0+-100	24546	C3-1/8-TO-100R-F
A4R2	0698-7221	0	1	RESISTOR 237 1% .05W F TC=0+-100	24546	C3-1/8-TO-237R-F
64R3	0698-7216	3	2	RESISTOR 147 1% .05W F TC=0+-100	24546	C3-1/8-TO-147R-F
64R4	0698-7202	7	0	RESISTOR 38.3 1% .05W F TC=0+-100	24546	C3-1/8-TO-30R3-F
A4R5	0698-7216	3		RESISTOR 147 1% .85W F TC=0+-100	24546	C3-1/8-TO-147R-F
A4U1	08550-60152	4	1	FIRST MIXER DIODE ASSEMBLY	28480	08558-60152
A5	08558-60097	6	1	SECOND CONVERTER	28480	0855800097
A5C1	0160-3036	8	2	CAPACITOR-FDTHRU 5000PF +80 -20% 200V	28480	0160-3036
A5C2	0160-3036	8		CAPACITOR-FDTHRU 5000PF 0SO -20% 200V	28480	0160-3036
A5C3	0160-4959	6	1	CAPACITOR-FDTHRU 10PF 5% 200V CER	33095	54-713-002-XSE-100J
A5C4	0140-0075	7	1	CAPACITOR-FDTHRU 22PF 10% 500V MICA	72982	666-053-0160-220K
A5CR1	1901-0950	2	1	DIODE-SM SIG SCHOTTKY	28410	1901-0950
A5J1	1250-1157	2	1	CONNECTOR-RF SMA FEM THD-HOLE 50-OIIM	28480	1250-1157
A5J2	1250-1435	9	1	CONN: RF: 500 OHM: SMC	28480	1250-1435
A5J3	1250-0829	3	1	CONNECTOR-RF SMC M SGL-HOLE-FR 50-OHM	28480	1250-0829
A5L1	9100-2255	4	6	INDUCTOR RF-CH-MLD 47ONH 10% .185DX.26LC	28480	9100-2255
A5L2	08558-80009	2	1	COIL, SECOND CONVERTER	28480	08558-80009
A5L3	08550-00034	5	1	COUPLING LOOP, INPUT	28400	08558-00034
A5L4	08558-00033	4	2	COUPLING LOOP, FILTER	28480	08558-00033
A5L5	08558-00033	4		COUPLING LOOP, FILTER	28480	08558-00033
A5MP1	08558-20122	4	1	OSCILLATOR HOUSING/SECOND CONV. COVER MATCHED TO ASFMP2 NOT SEPARATELY REPLA	28480	08558-20122
A5MP2	08558-20121	3	1	CAVITY BLOCK, SECOND CONVERTER MATCHED TO A5MP1; NOT SEPARATELY REPLACE	28480	08558-20121
A5MP3				NOT ASSIGNED		

See introduction to this section for ordering information

*Indicates factory selected value

Table 6-3. Replaceable Parts

Reference Designation	HP Part Number	C D	Qty	Description	Mfr. Code	Mfr Part Number
A5MP4	08558-20074	5	1	INSULATOR, COUPLING POST	28480	08558-20074
A5MP5	085513-00032	3	1	MOUNTING, MIXER DIODE	28480	08558-00032
A5MP6	08558-20120	2	1	COVER, OSCILLATOR	20480	08558-20120
A5MP7 THRU						
A5MP10	3030-0397	6	4	SCREW-SET 10-32 1-IN-LG FLAT-PT BRS	00000	ORDER BY DESCRIPTION
A5MP11	0380-0573	8	1	STANDOFF-HEX .625-IN-LG 10-32THD	00000	ORDER BY DESCRIPTION
A5MP12THRU						
A5MP17	0516-0041	4	6	SCREW-MACH 0-80 .125-IN-LG FIL-HD-SLT	00000	ORDER BY DESCRIPTION
A5MP18	2200-0151	0	1	SCREW-MACH 4-40 .75-IN-LG PAN-ND-POZI	00000	ORDER BY DESCRIPTION
A5MP19THRU						
A5MP22	2740-0001	3	4	NUT-HEX-DBL-CHAM 10-32-THD .109-IN-THK	00000	ORDER BY DESCRIPTION
A5MP23	08565-20068	6	1	CAPACITOR, INNER ELEMENT	28480	08565-20068
A5MP24	08565-20069	7	1	CAPACITOR, OUTER ELEMENT	28480	08565-20069
ASMP25	08565-20092	6	1	CAPACITOR, DIELECTRIC	28480	08565-20092
A5R1	0757-0346	2	30	RESISTOR 10 1% .125W F TC=0+-100	24546	C4-1/8-TR-10R0-F
A5A1	08558-60028	3	1	SECOND CONVERTER OSCILLATOR	28480	08558-60028
A5A1Q1	5086-4218	7	2	TRANSISTOR, NPN, MICROWAVE	28480	5086-4218
A5A1R1	0683-4705	8	1	RESISTOR 47 5% .25W FC TC=-400/+500	01121	CB4705
A5A1R2	0683-2715	6	1	RESISTOR 270 5% .25W FC TC=-400/+600	01121	C82715
A6	5086-7080	7	1	OSCILLATOR, YIG (DOES NOT INCL MTG. HDW)	28480	5086-7080
A6MP1	08558-00008	3	2	YIG BRACKET	28480	08558-00008
A6MP2	08558-00008	3		YIG BRACKET	28480	08558-00008
A6MP3	08558-00076	5	1	STRAP, YIG OSCILLATOR	28480	08558-00076
A6MP4	08558-20118	8	1	STANDOFF, NOTCHED	28460	08558-20118
A6MP5 THRU						
A6MP7	686558-20119	9	3	STANDOFF, PLAIN	28480	08558-20119
A7	08558-60126	2	1	FREQUENCY CONTROL	28480	08558R0126
A7C1	0180-1746	5	2	CAPACITOR-FXD 151F+-10% 20VDC TA	56289	150D156X9020812
A7C2	0180-1746	5		CAPACITOR-FXD 15UF+-10% 20VDC TA	56289	150D156X902082
A7C3	0160-3466	8	3	CAPACITOR-FXD 100PF +-10% 1KVDC CER	28480	0160-3466
A7C4	0180-0197	8		CAPACITOR--FXD 2,216F+-10% 20VDC TA	56289	150D225X9020A2
A7C5	0160-3094	8	4	CAPACITOR-FXD 1UF +-10% 10VDC CER	28480	0160-3094
A7C6	0160-3457	7	4	CAPACITOR-FXD 200RPF +-10% 250VDC CER	28480	0160-3457
A7C7	0160-3094	8		CAPACITOR-FXD 1UF +-10% 11RVDC CER	28480	0160-3094
A7C8	0180-0197	8		CAPACITOR-FXD 2,21UF+-10% 20VDC TA	56289	1500225X9020A2
A7C9	0180-1745	4	1	CAPACITOR-FXD 1,SUF+-10% 20VDC TA	56289	150D155X9020A2
A7C10	0160-3466	8		CAPACITOR-FXD 100PF +-10% 1KVDC CER	28480	0160-3466
A7C11	0160-2055	9	98	CAPACITOR-FXD .01UF +80-20% 10VDC CER	20480	0160-2055
A7C12	0160-2055	9		CAPACITOR-FXD .01UF +80-20% 10VDC CER	26480	0160-2055
A7C13	0180-1714	7	3	CAPACITOR-FXD 330UF+-10% 6VDC TA	56289	150D337X9006S2
A7C14	0180-1714	7		CAPACITOR-FXD 330UF+-10% 6VDC TA	56289	156B337X9006S2
A7CR1	1901-0040	1		DIODE-SWITCHING 30V SOMA 2NS 0D-35	28480	1901-0040
A7CR2	1901-0535	9	12	DIODE-SM SIC SCHOTTKY	28480	1901-0535
A7CR3	1901-0040	1		DIODE-SWITCHING 30V 50MA 2NS D0-35	28480	1901-0040
A7CR4	1901-0040	1		DIODE-SWITCHING 30V 50MA 2NS D0-35	28480	1901-0040
A7CR5	1901-0050	3		DIODE-SWITCHING 80V 200MA 2NS D0-35	28480	1901-0050
A7CR6	1901-0050	3		DIODE-SWITCHING 80V 20DMA 2NS D0-35	28480	1901-0050
A7CR7	1901-0050	3		DIODE-SWITCHING 80V 100MA 2NS D0-35	28480	1901-0050
A7CR8				NOT ASSIGNED		
A7CR9	1901--0040	1		DIODE-SWITCHING 30V 50MA 2NS D0-35	28480	1901-0040
A7L1	08558-80011	6	2	COIL, 100 UH	26480	08558-80011
A7L2	08558-80011	6		COIL, 100 UH	28460	08558-80011
A7MP1	1205-0002	9	3	HEAT SINK TO-5/TO-39-CS	28480	1205-0002
A7MP2	1205-0002	9		HEAT SINK TO-5/TO-39-CS	28480	1205-0002
A7MP3	1205-0002	9		HEAT SINK TO-5/TO-39-CS	28480	1205-0002
A7MP4	08558-00007	2	1	HEAT SINK, YIG DRIVE	28430	08558-00007
A7MP5 THRU						
A7MP8	0520-0129	8	4	SCREW-MACH 2-56 .312-IN-LG PAN-HD-POZI	00000	ORDER BY DESCRIPTION
A7MP9 THRU						
A7MP12	0610-0001	6	4	NUT-HEX-DBL-CHAM 2-56-THD .062-IN-THK	00000	ORDER BY DESCRIPTION
A7MP13THRU						
A7MP16	2190-0014	1	4	WASHER-LK INTL T NO. 2 .089-IN-ID	20480	2190-0014
A7Q1	1854-0039	7	6	TRANSISTOR NPN 2N30536 SI TO-39 PD=1W	3L585	2N3053S
A7Q2	1853-0451	5	3	TRANSISTOR PNP 2N3799 SI TO-18 PD=360MW	01295	2N3799
A7Q3	1854-0023	9	2	TRANSISTOR NPN SI TO-8IS PD=360MW	28486	1854-0023
A7Q4	1855-0417	7	4	TRANSISTOR J-.FET N--CHAN D-MODE TO-18 SI	26480	1855-0417
A7Q5	1854-0039	7		TRANSISTOR NPN 2N3053S SI TO-39 PD=1W	3L585	2N3053S
A7Q6	1854-0023	9		TRANSISTOR NPN SI TO-18 PD=360MW	28480	1854-0023
A7Q7	1854-0475	5	3	TRANSISTOR-DUAL NPN PD=750MW	28480	1854-0475
A7Q8	1853-0012	4	1	TRANSISTOR PNP 2N2904A SI TO-39 PD=600MW	01295	2N2904A
A7Q9	1854-0882	8	4	TRANSISTOR NPN PD=300MW FT=200MHZ	28480	1854-0882
A7Q10	1853-0007	7	26	TRANSISTOR PNP 2N3251 SI TO-18 PD=360MW	04713	2N3251

See introduction to this section for ordering information

*Indicates factory selected value

Table 6-3. Replaceable Parts

Reference Designation	HP Part Number	C D	Qty	Description	Mfr. Code	Mfr Part Number
A7Q11	1854-0882	8		TRANSISTOR NPN PD=300MNW FT=200MHZ	20480	1854-0882
A7Q12	1854-0039	7		TRANSISTOR NPN 2N30535 SI TO-39 PD=1W	3L585	2N3053S
A7Q13	1853-0007	7		TRANSISTOR PNP 2N3251 SI TO-18 PD=360MW	04713	2N3251
A7Q14	1853-0007	7		TRANSISTOR PNP 2N3251 SI TO-18 PD=360MW	04713	2N3251
A7Q15	1855-0062	8	5	TRANSISTOR J-FET N-CHAN D-MODE SI	28480	1855-0062
A7Q16	1855-0062	8		TRANSISTOR J-FET N-CHAN D-MODE SI	20480	1855-0062
A7Q17	1854-0404	0		TRANSISTOR NPN SI TO-18 PD=360NMW	28480	1854-0404
A7Q18	1853-0007	7		TRANSISTOR PNP 2N3251 SI TO-18 PD=360MW	04713	2N3251
A7Q19	1855-0420	2	1	TRANSISTOR J-FET 2N4391 N-CHAN D-MODE	01295	2N4391
A7Q20	1855-0062	8		TRANSISTOR J-FET N-CHAN D-MODE SI	28480	1855-0062
A7Q21	1B54-0404	0		TRANSISTOR NPN SI TO-18 PD=360MW	28480	1854-0404
A7Q22	1854-0404	0		TRANSISTOR NPN SI TO-18 PD=360HW	28480	1854-0404
A7Q23	1854-0404	0		TRANSISTOR NPN SI TO-18 PD=360MW	28480	1854-0404
A7Q24	1855-0062	5		TRANSISTOR J-FET N-CHAN D-MODE SI	28480	1855-0062
A7Q25	1854-0404	0		TRANSISTOR NPN SI TO-18 PD=360hW	28480	1854-0404
A7R1	2100-1754	9	2	RESISTOR-TRMR 50 5% WW SIDE-ADJ 1-TRN	28480	2100-1754
A7R2	2100-1760	7	1	RESISTOR-TRMR 5K 5% WW SIDE-ADJ 1-TRN	28480	2100-1760
A7R3	2100-1754	9		RESISTOR-TRMR 50 5% WW SIDE-ADS 1-TRN	28480	2100-1754
A7R4	2100-1757	2	4	RESISTOR-TRMR 500 5% WW SIDE-ADJ 1-TRN	28480	2100-1757
A7R5	2100-1757	2		RESISTOR-TRMR 500 5% WW SIDE-ADJ 1-TRN	28480	2100-1757
A7R6	2100-1756	1	1	RESISTOR-TRMR 200 5% WW SIDE-ADJ I-TRN	28480	2100-1756
A7R7	2100-3123	0	4	RESISTOR-TRMR 500 10% C SIDE-ADJ 17--TRN	02111	43P501
A7R8	2100-3123	0		RESISTOR-TRMR 500 10% C SIDE-ADJ 17--TRN	02111	43P501
A7R9	0698-3458	7	6	RESISTOR 348K 1% .125W F TC=0+-100	28480	0698-3450
A7R10	0757-0317	7		RESISTOR 1.33K 1% .125W F TC=0+-100	24546	C4-1/8-TO-1331-F
A7R11	0757-0465	6		RESISTOR 100K 1% .125W F TC=0+-100	24546	C4-1/8-TO-1003-F
A7R12	0683-1555	0	6	RESISTOR 1.5N 5% .25W FC TC=-.900/+1100	01121	CS1555
A7R13	0757-0280	3	23	RESISTOR 1K 1% .125W F TC=0+-100	24546	C4-1/8-TO-1001-F
A7R14	0757-0465	6		RESISTOR 100K 1% .125W F TC=0+-100	24546	C4-1/8-TO-1003--F
A7R15	0757-0465	6		RESISTOR 100K 1% .125W F TC=0+-100	24546	C4-1/8-TO-1003-F
A7R16	0757-0424	7		RESISTOR 1.1K 1% .125W F TC= 0+-100	24546	C4-1/8-TO-1101.-F
A7R17	0757-0274	5		RESISTOR 1.21K 1% .125W F TC=0+-100	24546	C4-1/8-TO-1211-F
A7R18	069B-3151	7		RESISTOR 2.87K 1% .125W F TC=0+-100	24546	C4-1/8-TO-2871-F
A7R19	0683-1555	0		RESISTOR 1.50 5% .25W FC TC=-900/+1100	01121	C81555
A7R20	0757-0438	3		RESISTOR 5.111K 1% .125W F TC=0+-100	24546	C4-1/8-TO-5111-F
A7R21	0698-3458	7		RESISTOR 348K 1% .125W F T 0=D+-100	28480	0698-3450
A7R22	0757-0465	6		RESISTOR 100K 1% .125W F TC=0+-100	24546	C4-1/8-TO-1003-F
A7R23	0683-1555	0		RESISTOR 1.5M 5% .25W FC TC=-900/+1100	01121	C155
A7R24	0698-3458	7		RESISTOR 348K 1% .125W F TC=0+-100	28480	0698-5458
A7R25	0757-0465	6		RESISTOR 100K 1% .125W F TC=+-100	24546	C4-1/8-TO-1003-F
47R26	0757-0438	3		RESISTOR 5.11K 1% .125W F TC=0+-10	24546	C4-1/8-TO-5111-F
A7R27	0698-0083	8	6	RESISTOR 1.96K 1% .125W F TC= 0+-100	24546	C4-1/8-TO-1961-F
A7R28	0698-3153	9		RESISTOR 3.83K 1% .125W F TC=0+-100	24546	C4-1/8-TO-3831-F
A7R29	0698-3151	7		RESISTOR 2.87K 1% .125W F TC=0+-100	24546	C4--1/8-TO-2871-F
A7R30	06B3-1555	0		RESISTOR 1.5N 5% .25W FC 'TC=-900/+1100	01121	CB1555
A7R31	0683-1555	0		RESISTOR 1.5M 5% .25W FC TC=-900/+1100	01121	C81555
A7R32	0757-0280	3		RESISTOR 1K 1% .125W F TC=2+-100	24546	C4-1/S-TO-1001 -F
A7R33	0698-3153	9		RESISTOR 3.83K 1% .125W F TC=2+-100	24546	C4-.1/8-TO-3831-F
A7R34	0757-0290	5	11	RESISTOR 6.19K 1% .125W F TC=0+-100	19701	MF4C1/8-TO-6191 -F
A7R35	0698-3154	0	2	RESISTOR 4.22K 1% .125W F TC=0+-100	24546	C4-1/8-TO-4221-F
A7R36	0698-3458	7		RESISTOR 348K 1% .125W F TC=D+-100	28480	0698-3458
A7R37	0698-3156	2		RESISTOR 14.7K 1% .125W F TC=0+-100	24546	C4-1/8-TO-1472-F
A7R38	0698-3453	2	1	RESISTOR 196K 1% .125W F TC=0+-100	24546	C4-1/8-10-1963-F
A7R39	0757-0401	0	19	RESISTOR 100 1% .125W F TC=2+-100	24546	C4-1/S-TO-101-F
A7R40	0698-3458	7		RESISTOR 348K 1% .125W F TC= 0+-100	28480	06798-2458
A7R41	0757-0470	3	2	RESISTOR 162K 1% .125W F TC=0+-100	24546	C4-1/8-TO-1623.-F
A7R42	0698-3160	8	4	RESISTOR 31.6K 1% .125W F TC=0+-100	24546	C4--1/8-TO-3162-F
A7R43	0757-0470	3		RESISTOR 162K 1% .125W F TC=0+-1 00	24546	C4- 1/8--1T623--F
A7R44	0757-0401	0		RESISTOR 100 1% .125W F TC=0+-800	24546	84-1/8-TO-101 F
A7R45	0757-0401	0		RESISTOR 100 1% .125W F TC=0+-100	24546	C4-1/8-TO-101-F
A7R46	0757-0290	5		RESISTOR 6.19K 1% .125W F TC=0+-100	19701	1/8-0-191-F
A7R47	0757-0199	3		RESISTOR 21.5K 1% .125W F TC=0+-100	24546	C42/8-1-1--F
A7R48	0698-3151	7		RESISTOR 2.87K 1% .125W F TC=0+-100	24546	C4-01/8-0-2871-F
A7R49	0698-6271	8	1	RESISTOR 3K .1% .125W F TC=0+-50	28480	0698-6271
A7R50	0698-6315	1		RESISTOR 503.1 .12X .125W F TC=0+-100	03888	PME55-1/8-TO-503R1-C
A7R51	0683-1555	0		RESISTOR 1.5M 5% .25W FC TC=-800/+1100	01121	C81555
A7R52	0698-7799	7	1	RESISTOR 2K .25% .125W F TC=0+-100	19701	NF4C1/8-10-2001-C
A7R53	0698-8323	5	1	RESISTOR 2.76K .25% .125W F TC=0+-50	19701	MF4C1/8-T2-2761-C
A7R54	0698-3458	7		RESISTOR 348K 1% .125W F TC= 0-1100	28480	0698-345 8
A7R55	0698-3438	3	3	RESISTOR 147 1% .125W F TC=0+-100	84546	C4-1/8-TO-147R-F
A7R56	0698-3162	0	5	RESISTOR 46.4K 1% .12 5W F -TC=0+-10	24546	C4-1/8-TO-4642-F
A7R57	0757-0317	7		RESISTOR 1.33K 1% .125W F TC=0+-100	24546	C4-1/8-TO-1331-F
A7R58	0757-0290	5		RESISTOR 6.19K 1% .15W F TC=0+-100	19701	MF4C1/8-TO-6191-F
A7R59	0757-0279	0	22	RESISTOR 3.16K 1% .125W F TC=0+-100	24546	C4-1/8-TO-3161-F
A7R60	0698-3153	9		RESISTOR 3.83K 1% .125W F TC=0+-100	24546	C4-1/8-TO-3831-F

See introduction to this section for ordering information
 *Indicates factory selected value

Table 6-3. Replaceable Parts

Reference Designation	HP Part Number	C D	Qty	Description	Mfr. Code	Mfr Part Number
A7R61	0757-0401	0		RESISTOR 100 1% .125W F TC=0+-100	24546	C4-1/8-TO-101-F
A7R62	0757-0416	7		RESISTOR 511 1% .125W F TC=0+-00	24546	C4-1/8-TO-511R-F
A7R63	0757-0199	3		RESISTOR 21.5K 1% .125W F TC=0+-1Dno	24546	C4-1/8-TO-2152-F
A7R64	0690-3450	9	4	RESISTOR 41.2K 1% .125W F TC=0+-100	24546	C4-1/8-TO-4222-F
A7R65	0757-0441	8	1	RESISTOR 8.25K 1% .125W F TC=0+-100	24546	C4-1/8-TO-8251-F
A7R66	0811-3247	4	1	RESISTOR 150 1% 7.5W PW TC=0+-20	21480	0811-3247
A7R67	0683-1065	7	2	RESISTOR 10N 5% .25W CC TC=-900/+1100	01121	C01065
A7R68	0698-3156	2		RESISTOR 14.7K 1% .125W F TC=0+-100	24546	C4-1/8-TO-1472-F
A7R69	0757-0199	3		RESISTOR 21.5K 1% .125W F TC=0+-100	24546	C4-1/8-TO-2152-F
A7R70	0757-0401	0		RESISTOR 100 1% .125W F TC=0+-100	24546	C4-1/8-TO-101-F
A7R71	0811-3246	3	1	RESISTOR 110 1% 7.5W PW TC=0+-20	28480	0811-3246
A7R72	2100-3094	4	1	RESISTOR-TRMR 100K 10% C SIDE-ADJ 17-TEN	02111	43P104
A7R73	0757-0462	3	1	RESISTOR 75K 1% .125W F TC=0+-100	24546	C41/8-TO-7502-F
A7R74	0757-0459	8		RESISTOR 56.2K 1% .125W F TC=0+-100	24546	C4-1/8-TO-5622--F
A7R75	0698-3428	1	1	RESISTOR 14.7 1% .125W F TC=0+-100	0388	PME55-1/8-TO-14R7-F
A7R76	0757-0199	3		RESISTOR 21.5K 1% .125W F TC=0+-100	24546	C4-1/8-TO-2152-F
A7R77	0698-3132	4	2	RESISTOR 261 1% .125W F TC=0+-100	24546	C4-1/8-TO-2610-F
A7R78	0683-1065	7		RESISTOR 10M 5% .25W CC TC=-900/+1100	01121	CB1065
A7R79	0757-0422	5	1	RESISTOR 909 1% .125W F TC=0+-100	24546	C4-1/8-TO-909R-F
A7TP1 THRU A7TP19**	1251-0600	0	60	CONNECTOR-SGL CONT PIN 1.14-MM-BSC-SZ SQ	20480	1251-0600
A7U1	1826-0261	8	2	IC OP AMP LOW-NOISE TO-99 PKG	28480	1826-0261
A7U2THRU A7U4	1826-0229	8	3	IC OP AMP LOW-DRIFT TO-99 PKG	06665	OP-05CJ
A7U5	1858-0032	8	2	TRANSISTOR ARRAY 14-PIN PLSTC DIP	3L585	CA3146E
A7U6	1826-0092	3	5	IC OP AMP GP DUAL TO-99 PKG	28480	1826-0092
A7VR1	1902-0033	4	3	DIODE--ZNR 1N823 6.2V 5% 0D0-7 PD=.4W	24046	1N823
A7VR2	1902-0680	7	1	DIODE-ZNR 1N827 6.2V 5% D00-7 PD=.4W	24046	1N827
A7VR3	1902-0202	9	2	DIODE-ZNR 15V 5% PD=1W IR=5UA	28480	1902-0202
A8	08558-60123	9	1	SWEEP GENERATOR	28480	0855860123
A8C1	0180-0197	8		CAPACITOR-FXD 2.2LIF+-10% 20VDC TA	56289	150D225X9020A2
A8C2	0160-3456	6	12	CAPACITOR-FXD 1000PF +-10% 1KVDC CER	28480	0160-3456
A8C3	0160-3402	2	1	CAPACITOR-FXD 11F +-5% 50VDC MET-POLYC	28480	0160-3402
A8C4	0160-3009	5	1	CAPACITOR-FXD 982PF +-1% 1 100VDC MICA	28480	0160-3009
A8C5	0180-0197	0		CAPACITOR-FXD 2.21JF+-10% 20VDC TA	56289	1500225X9020A2
A8C6	0160-3094	8		CAPACITOR-FXD .1UF +-10% 100VDC CER	28480	0160-3094
A8C7	0160-3456	6		CAPACITOR-FXD 100PF +-10% 1KVDC CER	28480	0160-3456
A8C8	0160-3466	8		CAPACITOR-FXD 100PF +-10% 1KVDC CER	28480	0160-3466
A8C9	0160-2257	3	1	CAPACITOR-FXD 10PF +-5% 50FVDC CER 0+-60	28480	0160-2257
A8C10	0160-2150	5	1	CAPACITOR-FXD 33PF +-5% 300VDC MICA	28480	0160-2150
A8C11	0180-0197	8		CAPACITOR-FXD 2.21WF+-10% 20VDC TA	56289	150D225X9020A2
A8C12	0140-0192	9	1	CAPACITOR-FXD 68PF +-5% 300VDC MICA	72136	DM15E68OJO300WVICR
A8C13	0180-0197	8		CAPACITOR--FXD 2.21UF+-10% 20VDC TA	56289	150D225X9020A2
A8C14	0160-4297	5	2	CAPACITOR-FXD .022UF +80-20% 100VDC CER	56289	C023F101H223ZS22-CDH
A8C15	0160-3456	6		CAPACITOR-FXD 100PF +-10% 1KVDC CER	28480	0160-3456
A8C16	0160-3094	5		CAPACITOR-FXD 1UF +-10% 100VDC CER	24800	0160-3094
A8C17	0160-3449	7	1	CAPACITOR-FXD 2000PF +-10% 250VDC CER	28480	0160-3449
A8C18	0160-4297	5		CAPACITOR-FXD .022UF +80-20% 100VDC CER	56289	C023F101H223ZS22-CDH
A8C19	0180-2205	3	1	CAPACITOR-FXD 33UF+-10% 35VDC TA	56289	150D334X9035A2
A8C20	0180-1743	2	1	CAPACITOR-FXD .1UF+-10% 35VDC TA	56289	150D104X9035A2
A8C21	0160-0163	6	1	CAPACITOR-FXD .033UF +-10% 200VDC POLYE	28480	0160-0163
A8C22	0160-2055	9		CAPACITOR-FXD 001UF +80-20% 100VDC CER	28480	0160--2055
A8C23	0160-0155	6	1	CAPACITOR-FXD 3300PF +-10% 200VDC POLYE	21480	0160-0155
A8C24	0160-0153	4	1	CAPACITOR-FXD 1000PF +-10% 200VDC POLYE	28480	0160-0153
A8C25	0160-0134	1	1	CAPACITOR-FXD 220PF +-5% 300VDC MICA	28480	0160-0134
A8C26	0180-0197	0		CAPACITOR-FXD 2.2UF+-10% 20VDC TA	56289	1500225X902A2
A8C27	0170-0066	9	1	CAPACITOR-FXD .027UF +10% 200VDC POLYE	28480	0170-0066
A8CR1	1901-0040	1		DIODE-SWITCHING 30V 50MA 2NS D0-35	28480	1901-0040
A8CR2	1901-0040	1		DIODE-SWITCHING 30V 50MA 2NS D0-35	28480	1901-0040
A8CR3	1901-0040	1		DIODE-SWITCHING 30V 50MA 2NS D0-35	28480	1901-0040
A8CR4	1901-0040	1		DIODE-SWITCHING 30V 50MA 2NS D0-35	28480	1901-0040
A8CR5	1901-0376	6	2	DIODE-GEN PRP 35V 50MA D00-35	28480	1901-0376
A8CR6	1901-0040	1		DIODE-SWITCHING 30V 50MA 2NS D0-35	28480	1901-0040
A8CR7	1901-0040	1		DIODE-SWITCHING 30V 50MA 2NS D00-35	28480	1901-0040
A8CR8	1901-0040	1		DIODE--SWITCHING 30V 50MA 2NS D00-35	28480	1901-0040
A8CR9	1901-0040	1		DIODE-SWITCHING 30V 50MA 2NS D00-35	28480	1901-0040
A8CR10	1901-0040	1		DIODE-SWITCHING 30V 50MA 2NS D00-35	28480	1901-0040
A8CR11	1901-0040	1		DIODE-SWITCHING 30V SOMA 2NS D00-35	28480	1901-0040
A8CR12	1901-0050	3		DIODE-SWITCHING 80V 200MA 2NS D00-35	28480	1901-0050
A8CR13	1901-0050	3		DIODE-SWITCHING 80V 200MA 2NS D00-35	28480	1901-0050
A8CR14	1901-0050	3		DIODE-SWITCHING 80V 200MA 2NS 00-35	28480	1901-0050
A8CR15	1901-0050	3		DIODE-SWITCHING 80V 200MA 2NS 00-35	28480	1901-0050

See introduction to this section for ordering information
 *Indicates factory selected value

**A7TP11 IS GND;A7TP12 NOT ASSIGNED.

Table 6-3. Replaceable Parts

Reference Designation	HP Part Number	C D	Qty	Description	Mfr. Code	Mfr Part Number
A8CR16	1901-0050	3		DIODE-SWITCHING 80V 200MA 2NS DO-35	28480	1901-0 050
A8CR17	1901-0050	3		DIODE-SWITCHING 80V 200MA 2HS DO-35	28480	1901-0050
A8CR18	1901-0050	3		DIODE-SWITCHING 80V 200MA 2NS DO-35	28480	1901-0050
A8CR19	1901-0050	3		DIODE-SWITCHING 80V 200MA INS DO-35	28480	1901-0050
A8CR20	1901-0050	3		DIODE-SWITCHING 80V 200MA 2NS DO-35	28480	1901-0050
A8CR21	1901-0050	3		DIODE-SWITCHING 80V 200MA 2NS DO-35	28480	1901-0050
A8CR22	1901-0050	3		DIODE-SWITCHING 80V 200MA 2NS 00-35	28480	1901-0050
A8CR23	1901-0040	1		DIODE-SWITCHING 30V 50MA 2NS DO-35	28480	1901-0040
A8CR24	1901-0050	3		DIODE-SWITCHING 80V 200MA 2NS DO-35	28480	1901-0050
A8CR25	1901-0040	1		DIODE-SWITCHING 30V 50MA 2NS DO-35	28480	1901-0040
A8MP1	1205-0202	1	1	THERMAL LINK DUAL TO-18-CS	28480	1205-0202
A8MP2	0380-0198	3	1	STANDOFF-RVT-ON .312-IN-LG 6-32THD	00000	ORDER BY DESCRIPTION
A8MP3	2360-0055	1	1	SCREW-MACH 6-32 .188-IN-LG BDG-HD-SLT	00000	ORDER BY DESCRIPTION
A8Q1	1854-0071	7	16	TRANSISTOR NPN SI PD=300MW FT=200MNHZ	28480	1854-0071
A8Q2	1855-0082	2	7	TRANSISTOR J-FET P-CHAN D-MODE SI	28480	1855-0082
A8Q3	1855-0082	2		TRANSISTOR J-FET P-CHAN D-MODE SI	28480	1855-0082
A8Q4	1853-0007	7		TRANSISTOR PNP 2N31251 SI TO-18 PD :360NW	04713	2N3251
A8Q5	1853-0020	4	5	TRANSISTOR PNP SI PD=300MW FT=15SNHZ	28480	1853-0020
A8Q6	1854-0071	7		TRANSISTOR NPN SI PD=300NW FT=200NHZ	28480	1854-0071
A8Q7	1853-0007	7		TRANSISTOR PNP 2N3251 SI TO-18 PD=360NW	04713	2N3251
A8Q8	1854-0071	7		TRANSISTOR NPN SI PD=300MW FT=200NHZ	28480	1854-0071
A8Q9	1854-0071	7		TRANSISTOR NPN SI PD=3SSNW FT=201HZ	28480	1854-0071
A8Q10	1854-0404	0		TRANSISTOR NPN SI TO-18 PD=360MW	28480	1854-0404
A8Q11	1855-0417	7		TRANSISTOR J-FET N-CHAN DOMODE TO-18 SI	28480	1855-0417
A8Q12	1853-0020	4		TRANSISTOR PNP SI PD=300MW FT=150MIIZ	28480	1853-0020
A8Q13	1854-0404	0		TRANSISTOR NPN SI TO-18 PD=360MW	28480	1854-0404
A8Q14	1854-0404	0		TRANSISTOR NPN SI TO-18 PD=360MW	28480	1854-0404
A8Q15	1854-0404	0		TRANSISTOR NPN SI TO-18 PD=360MW	28480	1854-0404
A8Q16	1854-0019	3	20	TRANSISTOR NPN SI TO-18 PD=360MW	28480	1854-0019
A8Q17	1854-0404	0		TRANSISTOR NPN SI TO-18 PS=360MW	28480	1854-0404
A8Q18	1854-0019	3		TRANSISTOR NPN SI TO-18 PD=360NW	28480	1854-0019
A8Q19	1854-0404	0		TRANSISTOR NPN SI TO-18 PS=360MW	28480	1854-0404
A8Q20	1854-0404	0		TRANSISTOR NPN SI TO-18 PD=360NW	28480	1854-0404
A8Q21	1854-0404	0		TRANSISTOR NPN SI TO-B18 PD=360MW	28480	1854-0404
A8Q22	1854-0404	0		TRANSISTOR NPN SI TO-18 PD=360MW	28480	1854-0404
A8Q23	1854-0404	0		TRANSISTOR NPN SI TO-18 PD=360MW	28480	1854-0404
A8Q24	1854-0019	3		TRANSISTOR NPN SI TO-S18 PD=360MW	28480	1854-0019
A8Q25	1855-0002	2		TRANSISTOR J-FET P-CHAN D-MODE SI	28480	1855-0082
A8Q26	1855-0082	2		TRANSISTOR J-FET P--CHAN D-MODE SI	28480	1855-0002
A8Q27	1855-0082	2		TRANSISTOR J-FET P-CHAN D-MODE SI	28480	1855-0082
A8Q28	1855-0082	2		TRANSISTOR J-FET P--CHAN D-MODE SI	28480	1855-0082
A8Q29	1855-0062	8		TRANSISTOR J-FET N-CHAN D-MODE SI	28480	1855-0062
A8Q30	1855-0082	2		TRANSISTOR J-FET P-CHAN D-MODE SI	28480	1855-0082
A8Q31	1854-0071	7		TRANSISTOR NPN SI PD=300MW FT=200MHZ	28480	1854-0071
A8Q32	1854-0071	7		TRANSISTOR NPN SI PD=300MW FT=20MHZ	28480	1854-0071
A8Q33	1854-0071	7		TRANSISTOR NPN SI PD=300MW FT=200MHZ	28480	1854-0071
A8Q34	1854-0071	7		TRANSISTOR NPN SI PD=300MW FT=200MHZ	28480	1854-0071
A8Q35	1854-0071	7		TRANSISTOR NPN SI PD=300MW FT=200MHZ	28480	1854-0071
A8Q36	1854-0071	7		TRANSISTOR NPN SI PD=300MW FT=200MHZ	28480	1854-0071
A8Q37	1853-0020	4		TRANSISTOR PNP SI PD=300MW FT=15MHZ	28480	1853-0020
A8Q38	1854-0071	7		TRANSISTOR NPN SI PD=300MW FT=200MHZ	28480	1854-0071
A8Q39	1854-0071	7		TRANSISTOR NPN ST PD=300MW FT=200MHZ	28480	1854-0071
A8Q40	1854-0071	7		TRANSISTOR NPN SI PD=300MW FT=200MHZ	28480	1854-0071
A8Q41	1854-0404	0		TRANSISTOR NPN SI TO-18 PD=360MW	28480	1854-0404
A8Q42	1854-0404	0		TRANSISTOR NPN SI TO-18 PD=360MW	28480	1854-0404
A8Q43	1854-0019	3		TRANSISTOR NPN SI TO-18 PD=360MW	28480	1854-0019
A8Q44	1854-0404	0		TRANSISTOR NPN SI TO-18 PD=360MW	28480	1854-0404
A8Q45	1854-0019	3		TRANSISTOR NPN SI TO-18 PD=360MW	28480	1854-0019
A8Q46	1854-0404	0		TRANSISTOR NPN SI TO-18 PD=3&0MW	28480	1854-0404
A8Q47	1854-0019	3		TRANSISTOR NPN SI TO-18 PD=3&0MW	28480	1854-0019
A8Q48	1854-0404	0		TRANSISTOR NPN SI TO-18 PD=360MW	28480	1854-0404
A8Q49	1854-0404	0		TRANSISTOR NPN SI TO--IS PD=360MW	28480	1854-0404
A8Q50	1853-0020	4		TRANSISTOR PNP SI, PD=300MW FT=150MHZ	28480	1353-0020(
A8Q51	1854-0071	7		TRANSISTOR NPN SI PD=300MW FT=20 0MHZ	28480	1854-0071
A8Q52	1855-0417	7		TRANSISTOR J--FET N-CHAN D-MODE TO-18 SI	28480	1855-0417
A8Q53	1854-0071	7		TRANSISTOR NPN SI PD=300MW FT=20PNDZ	28480	1854-0071
A8Q54	1853-0020	4		TRANSISTOR PNP SI PD=300MW FT=150MHZ	28480	1853-0020
A8Q55	1854-0071	7		TRANSISTOR NPN SI PD=300MW FT=200MHZ	28480	1854-0071
A8R1	0698-3450	9		RESISTOR 42.2K 1% .125W F TC=0+-100	24546	C4-1/8-TO-4222-F
A8R2	2100-3154	7	1	RESISTOR-TRMR 1K 10% C SIDE-ADJ 17-TRN	02111	43P102
A8R3	0757-0279	0		RESISTOR 3.16K 1% .125W F TC=0+-100	24546	C4-1/8-TO-3161-F
A8R4	0757-0419	0	6	RESISTOR 681 1% .125W F TC=0+-100	24546	C4-1/8-TO-681R-F
A8R5	0757-0459	8		RESISTOR 56.2K 1% .125W F TC=0+-100	24546	C4-1/8-TO-5622-F
A8R6	0698-3152	8	2	RESISTOR 3.48K 1% .125W F TC=0+-100	24546	C4-1/8-TO-3481-F
A8R7	0757-0442	9		RESISTOR 10K 1% .125W F TC=0+-100	24546	C4-1/8-TO-1002-F
A8R8	0757-0442	9		RESISTOR 10K 1% .125W F TC=0+-100	24546	C4-1/8-TO-1002-F
A8R9	0757-0444	1		RESISTOR 11.1K 17 .125W F TC=0+-100	24546	C4-1/8-TO-1212-F
A8R10	2100-3109	2	1	RESISTOR-TRMR 2K 10% C SIDE-ADJ 17--TRN	02111	43P202

See introduction to this section for ordering information
 *Indicates factory selected value

Table 6-3. Replaceable Parts

Reference Designation	HP Part Number	C D	Qty	Description	Mfr. Code	Mfr Part Number
A8R11	0698-3457	6		RESISTOR 316K 1% .125W F TC=0+-100	28480	0698-3457
A8R12	0698-3442	9	7	RESISTOR 237 1% .125W F TC=0+-100	24546	C4-1/8-TO-237R-F
A8R13	2100-3052	4	3	RESISTOR-TRMR 50 10% C SIDE-ADJ 17-TRN	02111	43P500
A8R14	0698-3446	3		RESISTOR 383 1% .125W F TC=0+-100	24546	C4-1/8-TO-383R-F
A8R15	0757-0424	7		RESISTOR 1.1K 1% .125W - TC=0+-100	24546	C4-1/8-TO-1101-F
A8R16	0698-7412	1	3	RESISTOR 13.3K .25% .125W F TC=0+-100	19701	MF4C1/8 -TO-1332-C
A8R17	0757-0442	9		RESISTOR 10K 1% .125W F TC=0+-100	24546	C4-1/8-TO-1002-F
A8R18	0757-0458	7		RESISTOR -51.1K 1% .125W F TC=0+-100	24546	C4-1/8-TO-5112-F
A8R19	0757-0465	6		RESISTOR 100K 1% .125W F TC=0+-100	24546	C4-1/8-TO-1003-F
A8R20	0757-0465	6		RESISTOR 100K 1% .125W F TC=0+-100	24546	C4-1/8-TO-1003-F
A8R21	0757-0279	0		RESISTOR 3.16K 1% .125W F TC=0+-100	24546	C4-1/8-TO-3161-F
A8R22	0757-0280	3		RESISTOR 1K 1% .125W F TC=0+-100	24546	C4-1/8-TO-1001-F
A8R23	0698-3444	1	17	RESISTOR 316 1% .125W F TC=0+-100	24546	C4-1/8-TO-316R-F
A8R24	0698-7794	2	8	RESISTOR 10K .25% .125W F TC=0+-100	19701	MF4C1/8-TO-1002-C
A8R25	0698-0416	7	1	RESISTOR 44K .25% .125W F TC=0+-50	19701	MF4C1/8-TO-4402-C
A8R26	0698-7794	2		RESISTOR 10K .25% .125W F TC=:0-100	19701	MF4C1/8-TO-1002-C
A8R27	0683-3355	2	3	RESISTOR 3.3M 5% .125W F TC=-900/+1100	01121	CB3355
A8R28	0683-3355	2		RESISTOR 3.3M 5% .25W F TC=-900/+1100	01121	CB3355
A8R29	0698-7794	2		RESISTOR 10K .25% .125W F TC=+100	19701	MF4C1/8-TO-1002-C
A8R30*	0698-7798	6	1	RESISTOR 5.25K .25% .125W F TC=0+-100	19701	MF4C1/8-TO-5251-C
A8R31	0757-0442	9		RESISTOR 10K 1% .125W F TC=0+-100	24546	C4-1/8 TO-1002-F
A8R32	0698-3160	8		RESISTOR 31.6K 1% .125W F TC=0+-100	24546	C4-1/8-TO-3162-F
A8R33	0698-3260	9		RESISTOR 464k 1% .125W F TC=:+-100	28480	0698-3260
A8R34	0698-3160	8		RESISTOR 31.6K 1% .125W F TC=0+-100	24546	C4-1/8-TO-3162-F
A8R35*	0757-0400	9		RESISTOR 90.9 1% .125W F TC=0+-100	24546	C4-1/8-TO -90R9-F
A8R36	0757-0401	0		RESISTOR 100 1% .125W F TC:TC=0+-100	24546	C4-1/8-TO-101-F
A8R37	0683-6845	1	1	RESISTOR 680K 5% .25W F TC=-800/+900	01121	CB6845
A8R38	3498-3457	6		RESISTOR 316K 1% .125W F TC=0+-100	28480	0698-3457
A8R39	0757-0442	9		RESISTOR 10K 1% .125W F TC=0+-100	24546	C4-1/8-TO-1002-F
A8R40	0698-3451	0	2	RESISTOR 133K 1% .125W F TC=0+-100	24546	C4-1/8-TO-1333-F
A8R41	0757-0459	8		RESISTOR 56.2K 1% .125W F TC=0+-100	24546	C4-1/8-TO-5622-F
A8R42	0698-7421	2	3	RESISTOR 40K .25% .125W F TC=0+-100	19701	MF4C1/8-TO-4002-C
A8R43	0698-3194	8	4	RESISTOR 20K .25% .125W F TC=0+-50	03888	PME55-1/8-T2-2002-C
A8R44	0698-7794	2		RESISTOR 10K .25% .125W F TC=0+-100	19701	MF4C1/8-TO-1002-C
A8R45	0698-3156	2		RESISTOR 14.7K 1% .125W F TC=+-100	24546	C4-1/8-TO-1472-F
A8R46	0757-0199	3		RESISTOR 21.5K 1% .125W F TC=0+-100	24546	C4-1/8-TO-2152-F
A8R47	0757-0346	2		RESISTOR 10 1% .125W F TC=0-1-100	24546	C4-1/8-TO-10R0-F
A8R48	0757-0465	6		RESISTOR 100K 1% .125W F TC:0+-100	24546	C4-1/8-TO-1003-F
A8R49	0757-0464	5	3	RESISTOR 90.9K 1% .125W F TC=0+ -100	24546	C4-1/8-TO-9092-F
AR850	0757-0442	9		RESISTOR 10K 1% .125W F TC-TC=0+-100	24546	C4-1/8-TO-1002-F
A8R51	0757-0279	0		RESISTOR 3.16K 1% .125W E TC=D+-100	24546	C4-1/8-TO-3161-F
A8R52	0757-0439	4	4	RESISTOR 6.81K 1% .125W F TC=0+-100	24546	C4-1/8-TO-6811-F
A8R53	0757-0460	1		RESISTOR 61.9K 1% .125W F TC=0+-100	24546	C4-1/8-TO-6192-F
A8R54	0757-0442	9		RESISTOR 10K 1% .125W F TC=0+-100	24546	C4-1/8-TO-1002-F
A8R55	0757-0442	9		RESISTOR 10K 1% .125W F TC=0+-100	24546	C4-1/8-TO-1002-F
A8R56	0757-0465	6		RESISTOR 100K 1% .125W F TC=0+-100	24546	C4-1/8-TO-1003-F
A8R57	0757-0439	4		RESISTOR 6.81K 1% .125W F TC=0+-100	24546	C4-1/8-TO-6811-F
A8R58	0757-0465	6		RESISTOR 100K 1% .125W F TC=0+ -100	24546	C4-1/8-TO-1003-F
A8R59	0757-0279	0		RESISTOR 3.16K 1% .125W F TC=0+-100	24546	C4-1/8-TO-3161-F
A8R60	0698-3160	8		RESISTOR 31.6K 1% .125W F TC=0+-100	24546	C4-1/8-TO-3162-F
A8R61	0757-0465	6		RESISTOR 100K 1% .125W F TC=0+-100	24546	C4-1/8-TO-1003-F
A8R62	0757-0465	6		RESISTOR 100K 1% .125W F TC=0+-100	24546	C4-1/8-TO-1003-F
A8R63	0757-0346	2		RESISTOR 10 1% .125W F TC=0+-100	24546	C4-1/8-TO-10R0-F
A8R64	0757-0199	3		RESISTOR 21.5K 1% .125W F TC=0+-100	24546	C4-1/8-TO-2152-F
A8R65	0757-0199	3		RESISTOR 21.5K 1% .125W F TC=0+-100	24546	C4-1/8-TO-2152-F
A8R66	0757-0199	3		RESISTOR 21 .5K 1% .125W F TC=0+-10S	24546	C4-1/8-TO-2152-F
A8R67	0757-0199	3		RESISTOR 21.5K 17 .125W F TC=04-100	24546	C4-1/8-TO-2152-F
A8R68	0698-7412	1		RESISTOR 3.3K 25% .125W F TC=0+-100	19701	MF4C1/8-TO-1332-C
A8R69	0757-1094	9	4	RESISTOR 1.47K 17 .125W F TC=0+-10	24546	C4-1/8-TO-1471-F
A8R70	0757-0199	3		RESISTOR 21.5K 1% .125W F TC=0+-100	24546	C4-1/8-TO-2152-F
A8R71	0757-0199	3		RESISTOR 21.5K 1- .125W F TC=D+-100	24546	C4-1/8-TO-2152-F
A8R72	2100-2850	8	2	RESISTOR-TRMR 10K 10% WW SIDE-ADJ 20-TRN	02660	3810P-103
A8R73	0757-0199	3		RESISTOR 21.5K 1% .125W F TC=+-100	24546	C4-1/8-TO-2152-F
A8R74*	0698-3151	7	8	RESISTOR 2.87K 1% .125W F TC=0+-10 0	24546	C4-1/8-TO-2071-F
A8R75	0757-0199	3		RESISTOR 21.5K 1% .125W F TC=0+-100	24546	C4-1/8-TO-2152-F
A8R76	0757-0442	9	47	RESISTOR 10K 1% .125W F TC=0+-100	24546	C4-1/8-TO-1002-F
A8R77	0757-0199	3		RESISTOR 21.5K 1% .125W F TC=0+-100	24546	C4-1/8-TO-2152-F
A8R78*	0757-0458	7	6	RESISTOR 51.1K 1% .125W F TC:0+-100	24546	C4-1/8-TO-5112-F
A8R79	0757-0199	3		RESISTOR 21.5K 1% .125W F TC=0+-100	24546	C4-1/8-TO-2152-F
A8R80	0757-0199	3		RESISTOR 21.5K 1% .1 -5W F TC=0+-100	24546	C4-1/8-TO-2152-F
A8R81	0757-0199	3		RESISTOR 21.5K 1% .125W F TC=0+-101	24546	C4-1/8-TO-2152-F
A8R82	0698-0085	0	2	RESISTOR 2.61K 1% .125W F TC=0+-100	24546	C4-1/8-TO-2611-F
A8R83	0698-3260	9		RESISTOR 464K 1% .125W F TC=0+-100	28480	0698-3260
A8R84	0757-0444	1		RESISTOR 12.1K 1% .125W F TC=0+-100	24546	C4-1/8-TO-1212-F
A8R85	2100-2850	8		RESISTOR-TRMR 10K 10% WW SIDE-ADJ 20-TRN	02660	3810P-103

See introduction to this section for ordering information
 *Indicates factory selected value

Table 6-3. Replaceable Parts

Reference Designation	HP Part Number	C D	Qty	Description	Mfr. Code	Mfr Part Number
A8R86	0698-7794	2		RESISTOR 10K .25% .125W F TC=0+-100	19701	MF4C1/8-TO-1002-C
A8R87	0757-0199	3		RESISTOR 21.5K 1% .125W F TC=0+-100	24546	C4-1/8-TO-2152-F
A8R88	0757-0199	3		RESISTOR 21.5K 1% .125W F TC=0+-100	24546	C4-1/8-TO-2152-F
A8R89*	0757-0460	1	3	RESISTOR 61.9K 1% .125W F TC=0+-100	24546	C4-1/8-TO-6192-F
A8R90	0698-7421	2		RESISTOR 40K .25% .125W F TC=0+-100	19701	MF4C1/8-TO-4002-C
A8R91	0757-0199	3		RESISTOR 21.5K 1% .125W F TC=0+-100	24546	C4-1/8-TO-2152-F
A8R92	0757-0289	2	7	RESISTOR 13.3K 1% .125W F TC=0+-100	19701	MF4C1/8-TO-1332-F
A8R93	0698-3194	0		RESISTOR 20K .25% .125W F TC=0+-50	03888	PME55-1/8-T2-2002-C
A8R94	0757-0199	3		RESISTOR 21.5K 1% .125W F TC=0+-100	24546	C4-1/8-TO-2152-F
A8R95*	0698-3153	9	10	RESISTOR 3.83K 1% .125W F TC=0+-100	24546	C4-1/8-TO-3831-F
A8R96	0698-7412	1		RESISTOR 13.3K .25% .125W F TC=0+-100	19701	MF4C1/8-TO-1332-C
A8R97	0757-0199	3		RESISTOR 21.5K 1% .125W F TC=0+-100	24546	C4-1/8-TO-2152-F
A8R98	0757-0442	9		RESISTOR 10K 1% .125W F TC=0+-100	24546	C4-1/8-TO-1002-F
A8RR99	0757-0199	3		RESISTOR 21.5K 1% .125W F TC=0+-100	24546	C4-1/8-TO-2152-F
A8R100	0757-0465	6		RESISTOR 100K 1% .125W F TC=0+-100	24546	C4-1/8-TO-1003-PF
A8R101	0698-7794	2		RESISTOR 10K .25% .125W F TC=0+-100	19701	MF4C1/8-TO-1002-C
A8R102	0757-0459	8		RESISTOR 56.2K 1% .125W F TC=0+-100	24546	C4-1/8-TO-5622-F
A8R103	0757-0442	9		RESISTOR 10K 1% .125W F TC=0+-100	24546	C4-1/8-TO-1002-F
A8R104	0698-3154	0		RESISTOR 4.22K 1% .125W F TC=0+-100	24546	C4-1/8-TO-4221-F
A8R105*	0698-3457	6	5	RESISTOR 316K 1% .125W F TC=0+-100	28480	0698-3457
A8R106	0757-0440	7	10	RESISTOR 7.5K 1% .125W F TC=0+-100	24546	C4-1/8-TO-7501-F
A8R107	0757-0442	9		RESISTOR 10K 1% .125W F TC=0+-100	24546	C4-1/8-TO-1002-F
A8R108	0757-0442	9		RESISTOR 10K 1% .125W F TC=0+-100	24546	C4-1/8-TO-1002-F
A8R109	0757-0442	9		RESISTOR 10K 1% .125W F TC=0+-100	24546	C4-1/8-TO-1002-F
A8R110	0698-3451	0		RESISTOR 133K 1% 3 .125W F TC=0+-100	24546	C4-1/8-TO-1333-F
A8R111	0757-0442	9		RESISTOR 10K 1% .125W F TC=0+-100	24546	C4-1/8-TO-1002-F
A8R112	0757-0442	9		RESISTOR 10K 1% .125W F TC=0+-100	24546	C4-1/8-TO-1002-F
A8R113	0698-7794	2		RESISTOR 10K .25% .125W F TC=0+-100	19701	MF4C1/8-TO-1002-C
A8R114	0757-0459	B		RESISTOR 56.2K 1% .125W F TC=0+-100	24546	C4-1/8-TO-5622-F
A8R115	0757-0442	9		RESISTOR 10K 1% .125W F TC=0+-100	24546	C4-1/8-TO-1002-F
A8R116	0757-0442	9		RESISTOR 10K 1% .125W F TC=0+-100	24546	C4-1/8-TO-1002-F
A8R117	0698-3238	1	1	RESISTOR 2.5K .25% .125W F TC=0+-50	28480	0698-3238
A8R118	0757-0465	6		RESISTOR 100K 1% .125W F TC=0+-100	24546	C4-1/8-TO-1003-F
A8R119	0698-7794	2		RESISTOR 10K .25% .125W F TC=0+-100	19701	MF4C1/8-TO-1002-C
A8R120	0698-7086	5	1	RESISTOR 1.02K .25% .125W F TC=0+-100	28480	0690-7086
A8R121	0698-8322	4		RESISTOR 111 .2% .125W F TC=0+-100	19701	MF4C1/8-TO-111R-C
A8R122	0683-1055	5	3	RESISTOR 1M 5% .25W FC TC=0+-800/+900	01121	CB1055
A8R123	0683-1055	5		RESISTOR 1M 5% .25W FC TC=0+-800/+900	01121	CB1055
A8R124	0757-0465	6		RESISTOR 100K 1% .125W F TC=0+-100	24546	C4-1/8-TO-1003-F
A8R125	0757-0461	2	1	RESISTOR 68.1K 1% .125W F TC=0+-100	24546	C4-1/8-TO-6812-F
A8R126	0757-0442	9		RESISTOR 10K 1% .125W F TC=0+-100	24546	C4-1/8-TO-1002-F
A8R127	0698-7421	2		RESISTOR 40K .25% .125W F TC=0+-100	19701	MF4C1/8-TO-4002-C
A8R128	0757-0442	9		RESISTOR 10K 1% .125W F TC=0+-100	24546	C4-1/8-TO-1002-F
A8R129	0698-3194	8		RESISTOR 20K .25% .125W F TC=0+-50	03888	PME55-1/8-T2-2002-C
A8R130	0683-3355	2		RESISTOR 3.3M 5% .25W FC TC=0+-900/+1100	01121	CB3355
A8R131	0757-0442	9		RESISTOR 10K 1% .125W F TC=0+-100	24546	C4-1/8-TO-1002-F
A8R132	0698-3194	8		RESISTOR 20K .25% .125W F TC=0+-50	03888	PME55-1/8-T2-2002-C
A8TP1 THRU						
A8TP9	1251-0600	0		CONNECTOR-SGL CONT PIN 1.14-MM-BSC-S7 SQ	28480	1251-0600
A8U1	1820-0223	0	1	IC OP AMP GP TD-99 PKG	3L585	CA301AT
A8U2	1826-0092	3		IC OP AMP GP DUAL TO-99 PKG	28480	1826-0092
A8U3	1826-0261	8		IC OP AMP LOW-NOISE TO-99 PKG	28480	1826-0261
A8VR1	1902-0025	4	2	DIODE-ZNR 10V 5% DO-35 PD=4W TC=.06%	28480	1902-0025
A8VR2	1902-3139	7	1	DIODE-ZNR 8.25V 5% DO-35 PD=.4W	28480	1902-3139
A8VR3	1902-0049	2	1	DIODE-ZNR 6.19V 5% DO-35 PD=.4W	28480	1902-0049
A9	08558-60154	6	1	THIRD CONVERTER	28480	08558-60154
A9	08558-60155	7	1	THIRD CONVERTER, OPTION 001/002	28480	08558-60155
A9C1	0160-3878	6	12	CAPACITOR-FXD 1000PF +-20% 10VDC CER	28480	0160-3878
A9C2	0160-3878	6		CAPACITOR-FXD 1000PF +-20% 1009VDC CER	28480	0160-3878
A9C3	0160-3878	6		CAPACITOR-FXD 1000PF +-20% 100VDC CER	28480	0160-3878
A9C4	0160-2249	3	1	CAPACITOR-FXD 4.7PF +-25PF 500VDC CER	28480	0160-2249
A9C5	0160-2264	2	1	CAPACITOR-FXD 20PF +-5% 500VDC CER 0+-30	28480	0160-2264
A9C6	0160-3878	6		CAPACITOR-FXD 1000PF +-20% 100VDC CER	28480	0160-3878
A9C7	0160-3878	6		CAPACITOR-FXD 1000PF +-20% 100VDC CER	28480	0160-3878
A9C8	0160-3878	6		CAPACITOR-FXD 1000PF +-20% 100VDC CER	28480	0160-3878
A9C9	0160-3878	6		CAPACITOR-FXD 1000PF +-20% 100VDC CER	28480	0160-3878
A9C10	0160-2207	3	5	CAPACITOR-FXD 300PF +-5% 300VDC MICA	28480	0160-2207
A9C11	0140-0195	2	2	CAPACITOR-FXD 130PF +-5% 300VDC MICA	72136	DM15F131J0300WV1CR
A9C12	0140-0198	5	1	CAPACITOR-FXD 200PF +-5% 300VDC MICA	72136	DM15F201J0300WV1CR
A9C13	0180-0197	3		CAPACITOR--FXD 2.2UF+-10% 20VDC TA	56289	150D225X9020A2
A9C14	0180-0197	8		CAPACITOR-FXD 2.2UF+-10% 20VDC TA	56289	150D225X9020A2
A9C15	0160-3878	6		CAPACITOR-FXD 100PF +-20% 100VDC CER	28480	0160-3878

See introduction to this section for ordering information
 *Indicates factory selected value

Table 6-3. Replaceable Parts

Reference Designation	HP Part Number	C D	Qty	Description	Mfr. Code	Mfr Part Number
A9C16	0160-3456	6	10	CAPACITOR-FXD 1000PF +-10% 1KVDC CER	28480	0160-3456
A9C17	0160-3879	7		CAPACITOR-FXD .01UF +-20% 100VDC CER	28480	0160-3879
A9C18	0160-3879	7		CAPACITOR-FXD .01UF +-20% 100VDC CER	28480	0160-3879
A9C19	0160-3879	7		CAPACITOR-FXD .01UF +-20% 100VDC CER	28480	0160-3879
A9C20	0160-3879	7		CAPACITOR-FXD .01UF +-20% 100VDC CER	28480	0160-3879
A9CR1	1901-0040	1	23	DIODE-SWITCHING 30V 50MA 2NS DO-35	28480	1901-0040
A9CR2	1901-0040	1		DIODE-SWITCHING 30V 50MA 2NS DO-35	28480	1901-0040
A9CR3	1901-1070	9		DIODE-PIN 110V	28480	1901-1070
A9CR4	1901-1070	9		DIODE-PIN 110V	28480	1901-1070
A9CR5	1901-0040	1		DIODE-SWITCHING 30V 50MA 2NS DO-35	28480	1901-0040
A9CR6	1901-0040	1		DIODE-SWITCHING 30V 50MA 2NS DO-35	28480	1901-0040
A9CR7	1901-0070	7	2	DIODE-PWR RECT 600V 750MA DO-29	28480	1901-0070
A9CR8	1901-0070	7		DIODE-PWR RECT 600V 750MA DO-29	28480	1901-0070
A9E1	9170-0029	3	21	CORE-SHIELDING BEAD	28480	9170-0029
A9E2	1200-0173	5	3	INSULATOR-XSTR DAP-GL	28480	1200-0173
A9E3	1200-0173	5		INSULATOR-XSTR DAP-GL	28400	1200-0173
A9J1	1250-0830	6	4	CONNECTOR-RF SMC M SGL-HOLE-FR 50-OHM	28480	1250-0830
A9J2	1250-0830	6		CONNECTOR-RE SMC M SGL-HOLE-FR 50-OHM	28480	1250-0830
A9L1	9100-2255	4		INDUCTOR RF-CH-MLD 470NH 10% .105DX.26LG	28480	9100-2255
A9L2	9100-2255	4		INDUCTOR RF-CH-MLD 470NH 10% .105DX.26LG	28480	9100-2255
A9L3	08558-80002	5	1	COIL, NEUTRALIZING	28480	08558-80002
A9L4	08558-80012	7	1	COIL, FREQUENCY ADJUST	28480	08558-80012
A9L5	9100-2255	4		INDUCTOR RF-CH-MLD 470NH 10% .105DX.26LG	28480	9100-2255
A9L6	9100-2250	9	1	INDUCTOR RF-CH-MLD 180NH 10% .105DX.26LG	28480	9100-2250
A9L7	9100-2255	4		INDUCTOR RF-CH-MLD 470NH 10% .105DX.26LG	28480	9100-2255
A9L8	9100-2255	4		INDUCTOR RF-CH-MLD 470NH 10% .105DX.26LG	28480	9100-2255
A9L9	9100-2249	6	2	INDUCTOR RF-CH-MLD 150NH 10% .105DX.26LG	28480	9100-2249
A9L10	9100-2249	6		INDUCTOR RF-CH-MLD 150NH 10% .105DX.26LG	28480	9100-2249
A9L11	9100-2276	9	1	INDUCTOR RF-CH-MLD 100UH 10% .185DX.26L.G	28480	9100-2276
A9L12	9140-0178	0	4	INDUCTOR RF-CH-MLD 12UH 10% .166DX.385LG	28480	9140-0178
A9L13	9140-0178	0		INDUCTOR RF-CH-MLD 12UH 10% .166DX.385LG	28480	9140-0178
A9L14	9140-0143	9	1	INDUCTOR RF-CH-MLD 3.3UH 10% .105DX.26LG	28480	9140-0143
A9L15	9100-1623	8	2	INDUCTOR RF-CH-MLD 27UH 5% .166DX.385LG	28480	9100-1623
A9L16	9100-1623	8		INDUCTOR RF-CH-MLD 27UH 5% .166DX.385L.G	28480	9100-1623
A9MP1	08558-00014	1	1	COVER, THIRD CONVERTER	28480	08558-00014
A9MP2	08558-00079	8	1	RF SHIELD, MIXER	28480	08558-00079
A91Q	1854-0345	8	6	TRANSISTOR NPN 2N5179 SI TO-72 PD=200MW	04713	2N5179
A9Q2	1854-0247	9	2	TRANSISTOR NPN SI TO-39 PD=1W FT=800MHZ	28480	1854-0247
A9Q3	1854-0247	9		TRANSISTOR NPN SI TO-39 PD=1W FT=800MHZ	28480	1854-0247
A9Q4	1854-0019	3		TRANSISTOR NPN SI TO-18 PD=360MW	28480	1854-0019
A9Q5	1854-0404	0		TRANSISTOR NPN SI TO-18 PD=360MW	28480	1854-0404
A9R1	2100-2522	1	4	RESISTOR-TRMR 10K 10% C SIDE-ADJ 1-TRN	30983	ET50X103
A9R2	0757-0280	3		RESISTOR 1K 1% .125W F TC=0+-100	24546	C4-1/8-TO-001-F
A9R3	0757-0346	2		RESISTOR 10 1% .125W F TC=0+-100	24546	C4-1/8-TO-10R0-F
A9R4*	0757-0424	7	8	RESISTOR 1.1K 1% .125W F TC=0+-100	24546	C4-1/8-TO-1101-F
A9R5	2100-3123	0		RESISTOR-TRMR 500 10% C SIDE-ADJ 17-TRN	02111	43P501
A9R6	0757-0346	2		RESISTOR 10 1X .125W F TC=0+-100	24546	C4-1/8-TO-10R0-F
A9R7	0757-0346	2		RESISTOR 10 1% .125W F TC=0+-100	24546	C4-1/8-TO-10R0-F
A9R8	0757-0799	9	1	RESISTOR 121 1x .5W F TC=0+-100	28480	0757-0799
A9R9*	0757-0274	5	8	RESISTOR 1.21K 1% .125W F TC=0+-100	24546	C4-1/8-TO-1211-F
A9R10	0698-7188	8	1	RESISTOR 10 1% .50W F TC=0+-100	24546	C3-1/8-TO-10R-F
A9R10	0698-7196	8	1	RESISTOR 21.5 1% .05W F TC=0+-100 (OPTION 001/002)	24546	C3-1/8-TO-21R5-F
A9R10	0698-7203	8	1	RESISTOR 42.2 1% .05W F TC=0+-100	24546	C3-1/8-TO-42R2-F
A9R11	0698-7206	1	1	RESISTOR 56.2 1% .05W F TC=0+-100 (OPTION 001/002)	24546	C3-1/8-TO-56R2-F
A9R12*	0757-0416	7		RESISTOR 511 1% .125W F TC=1+-100	24546	C4-1/8-TO-511R-F
A9R12*	0757-0416	7	12	RESISTOR 511 1% .125W F TC=0+-100 (OPTION 001/002)	24546	C4-1/8-TO-511R-F
A9R13	0698-3450	9		RESISTOR 42.2K 1% .125W F TC=0+-100	24546	C4-1/8-TO-4222-F
A9R14*	0757-0463	4	1	RESISTOR 02.5K 1X .125W F TC=0+-100	24546	C4-1/8-TO-0252-F
A9R15	0698-3438	3		RESISTOR 147 1% .125W F TC=0+-100	24546	C4-1/8-TO-147R-F
A9R16	0683-0475	1	2	RESISTOR 4.7 5% .25W FC TC=-400/+500	01121	CB47G5
A9R17	0757-0464	5		RESISTOR 90.9K 1% .125W F TC=0+-100	24546	C4-1/8-TO-9092-F
A9R18	0698-3150	6	5	RESISTOR 2.37K 1% .125W F TC=0+-100	24546	C4-1/8-TO-2371-F
A9R19	0698-3156	2		RESISTOR 14.7K 1Z .125W F TC=0+-100	24546	C4-1/8-TO-1472-F
A9R20	0757-0418	9	4	RESISTOR 619 1% .125W F TC=0+-100	24546	C4-1/8-TO-619R-F
A9R21	0698-3159	5	0	RESISTOR 26.1K 1% .125W F TC=0+-100	24546	C4-1/8-TO-2612-F
A9R22	0757-0317	7		RESISTOR 1.33K-1% .125W F TC=0+-100	24546	C4-1/8-TO-1331-F
A9R23	0698-3447	4	0	RESISTOR 422 1% .125W F T=0+-100	24546	C4-1/8-TO-422R-F
A9R24	0757-0280	3		RESISTOR 1K 1% .125W F TC=0+-100	24546	C4-1/8-TO-1001-F
A9R25	0757-0418	9		RESISTOR 619 1% .125W F TC=0+-100	24546	C4-1/8-TO-619R-F

See introduction to this section for ordering information
 *Indicates factory selected value

Table 6-3. Replaceable Parts

Reference Designation	HP Part Number	C D	Qty	Description	Mfr. Code	Mfr Part Number
A9U1	0955-0076	5	1	MIXER, DOUBLE BALANCED	28480	0955-0076
A9VR1	1902-3104	6	1	DIODE-ZNR 5.62V 5% DO-35 PD=.4W	28480	1902-3104
A9VR2	1902-0025	4		DIODE-ZNR 10V 5% DO-35 PD=.4W TC=+.06%	28480	1902-0025
A9Z1	1GA1-8001	3	1	SURFACE ACOUSTICAL. WAVE RESONATOR (SAWR)	28480	1GA1-8001
A10	08558-60010	3	1	SECOND IF	28480	08558-60010
A10C1	0121-0457	9	3	CAPACITOR-V TRMR-PSTN 8-8.5PF 750V	18736	TP9
A10C2	0121-0457	9		CAPACITOR-V TRMR-PSTN .8-8.5PF 750V	18736	TP9
A10C3	0121-0457	9		CAPACITOR-V TRMR-PSTN .8-8.5PF 750V	18736	TP9
A10C4	0160-3878	6		CAPACITOR-FXD 1D00PF +20% 100VDC CER	28480	0160-3878
A10C5	0160-3878	6		CAPACITOR-FXD 1000PF +20% 100VDC CER	28480	0160-3878
A10C6	0160-3877	5	1	CAPACITOR-FXD 100PF +-20% 200VDC CER	28480	0160-3877
A10C7	0160-3878	6		CAPACITOR-FXD 100PF +20% 100VDC CER	28480	0160-3878
A10C8	0160-2236	8	3	CAPACITOR-FXD 1PF +-25PF 500VDC CER	28480	0160-2236
A10C9	0160-2250	6	9	CAPACITOR-FXD 5.1PF +-25PF 500 VDC CER	28480	0160-2250
A10C10	0160-3878	6		CAPACITOR-FXD 1000PF +-20% 100VDC CER	28480	0160-3878
A10C11	0160-2250	6		CAPACITOR-FXD 5.1PF +-25PF 500 VDC CER	28480	0160-2250
A10C12	0160-2250	6		CAPACITOR-FXD 5.1PF +-25PF 500VDC CER	28480	0160-2250
A10C13	0160-2252	8	1	CAPACITOR-FXD 6.2PF +-25PF 500VDC CER	28480	0160-2252
A10C14	0160-2250	6		CAPACITOR-FXD 5.1PF +-25PF 500VDC CER	28480	0160-2250
A10C15	0160-2250	6		CAPACITOR-FXD 5.1PF +-25PF 500VDC CER	28480	0160-2250
A10J1	1250-0830	6		CONNECTOR-RF SMC M SGL-HOLE-FR 50-OHM	28480	1250-0830
A10J2	1250-0830	6		CONNECTOR-RF SMC M SGL-HOLE-FR 50-OHM	28480	1250-0830
A10L1	9100-2247	4	2	INDUCTOR RF-CH-MLD 100NH 10% .105DX.26LG	28480	9100-2247
A10L2	08558-80005	8	1	COIL, PAR TANK	28480	08558-80005
A10L3	08558-80003	6	3	COIL, BANDPASS FILTER	28480	08558-80003
A10L4	08558-80003	6		COIL, BANDPASS FILTER	28480	08558-80003
A10L5	08558-80003	6		COIL, BANDPASS FILTER	28480	08558-80003
A10MP1	08558-00015	2	1	COVER, SECOND I. F	28480	08558-00015
A10MP2	1200-0172	4	1	INSULATOR-XSTR DAP-GL	28480	1200-0172
A10Q1	1853-0007	7		TRANSISTOR PNP 2N3251 SI TO-18 PD=360MW	04713	2N3251
A10Q2	5086-4218	7		TRANSISTOR, NPN MICROWAVE	28480	5086-4218
A10R1	0757-0442	9		RESISTOR 10K 1% .125W F TC=0+-100	24546	C4-1/8-T0-1002-F
A10R2	0698-3136	8	3	RESISTOR 17.8K 1% .125W F TC=0+-100	24546	C4-1/8-T0-1782-F
A10R3	0757-0438	3		RESISTOR 5.11K 1% .125W F TC=0+-100	24546	C4-1/8-T0-5111-F
A10R4	0698-3442	9		RESISTOR 237 1% .125W F TC=0+-100	24546	C4-1/8-T0-237R-F
A10R5	0757-0280	3		RESISTOR 1K 1% .125W F TC=0+-100	24546	C4-1/8-T0-1001-F
A11	08558-60128	4	1	BANDWIDTH FILTER NO. 1	28480	08558-60128
A11C1	0160-2055	9		CAPACITOR-FXD .01UF +80-20% 100VDC CE0R	28480	0160-2055
A11C2	0160-0127	2	2	CAPACITOR-FXD 11JF -20% 2SVDC CER	28480	0160-0127
A11C3	0160-2236	8		CAPACITOR-FXD 1PF +-2PF 5S00VDC CER	28480	0160-2236
A11C4	0160-2055	9		CAPACITOR-FXD .016F +80-20% 1100VDC CER	28480	0160-2055
A11C5	0160-2055	9		CAPACITOR-FXD .0UF +00-20 1001VDC CER	28480	0160-2055
A11C6	0160-2055	9		CAPACITOR-FXD .01UF +80-20% 100VDC CER	28480	0160-2055
A11C7	0160-2055	9		CAPACITOR-FXD .01UF +80-20% 100VDC CER	28480	0160-2055
A11C8	0160-2207	3		CAPACITOR-FXD 500PF 1-5% 300VDC MICA	28480	0160-2207
A11C9	0160-2055	9		CAPACITOR-FXD .01UF +80-20% 10VDC CER	28480	0160-2055
A11C10	0160-2055	9		CAPACITOR --FXD .01UF +80-207 10VDC CER	28480	0160-2055
A11C11	0160-2055	9		CAPACITOR-FXD .01UF +80-20% 100VDC CER	28480	0160-2055
A11C12	0160-2055	9		CAPACITOR-FXD .01UF +80-20% 100VDC CER	28480	0160-2055
A11C13	0160-3456	6		CAPACITOR-FXD 1000PF +-10% x 1KVDC CER	28480	0160-3456
A11C14	0160-2250	6		CAPACITOR-FXD 5.1PF +-25'5PF 500VDC CER	28480	0160-2250
A11C15	0121-0059	7	4	CAPACITOR-V TRMR-CER 2-8PF 350V PC-MTG	52763	304324 2/8PF NPO
A11C16				NOT ASSIGNED		
A11C17	0160-2055	9		CAPACITOR-FXD .01UF +80-.20 100VDC CER	28480	0160-2055
A11C18	0160-2055	9		CAPACITOR-FXD .01UF +0--20% 1D0VDC 10 ER	28480	0160-2055
A11C19	0160-2055	9		CAPACITOR-FXD .01UF +80-20X 100VDC CER	28480	0160-2055
A11C20*	0140-0194	1	5	CAPACITOR-FXD 110PF +-5% 300VDC MICA	72136	DM15F111J0300D0WV1CR
A11C21	0160-3431	7	4	CAPACITOR-FXD 6.8 +-5PF 500VDC	28480	0160-3431
A11C22	0160-4084	8		CAPACITOR-FXD .1UF +20% 50VDC	28480	0160-4084
A11C23	0121-0036	0	4	CAPACITOR-V TRMR-CER 5.5-18PF 350V	52763	304324 5.5/18PF NPO
A11C24				NOT ASSIGNED		
A11C25	0121-0446	6	4	CAPACITOR-V TRMR-CER 4.5-20PF 160V	28480	0121-0446
A11C26	0160-2055	9		CAPACITOR FXD .01UF +80-20% 100VDC CER	28480	0160-2055
A11C27	0160-2055	9		CAPACITOR-FXD .01UF +80-20% 100VDC CER	28480	0160-2055
A11C28	0160-2055	9		CAPACITOR-FXD .01UF +10-20% 10VDC CER	28400	0160-2055
A11C29	0160-3456	6		CAPACITOR-FXD 1000PF +-10% 1KVDC CER	28480	0160-3456
A11C30	0160-2055	9		CAPACITOR-FXD .01UF R80-20% 100VDC CER	28400	0160-2055
A11C31	0160-3456	6		CAPACITOR-FXD 1000PF +-10% 1KVDC CER	28480	0160-3456
A11C32	0160-4084	8		CAPACITOR-FXD .1UF +-20% 50VDC CER	28480	0160-4084
A11C33	0160-2207	3		CAPACITOR-FXD 300PF +-5% 300VDC MICA	28480	0160-2207
A11C34	0160-2055	9		CAPACITOR-FXD .01UF +80-20% - 100VDC CER	28480	0160-2055
A11C35	0160-2055	9		CAPACITOR-FXD .01UF +80-20% x100VDC CER	28480	0160-2055

See introduction to this section for ordering information

*Indicates factory selected value

Table 6-3. Replaceable Parts

Reference Designation	HP Part Number	C D	Qty	Description	Mfr. Code	Mfr Part Number
A11C36	0160-2055	9		CAPACITOR-FXD .01UF +80-20% 100VDC CER	28480	0160-2055
A11C37	0160-2250	6		CAPACITOR-FXD 5.1PF +- .25PF 500VDC CER	28480	0160-2250
A11C38	0121-0059	7		CAPACITOR-V TRMR-CER 2-8PF 350V PC-MTG	52763	304324 2/8PF NPO
A11C39				NOT ASSIGNED		
A11C40	0160-2055	9		CAPACITOR-FXD .01UF +80-20% 100VDC CER	28480	0160-2055
A11C41	0160-3456	6		CAPACITOR-FXD 1000PF +-10% 1KVDC: CER	28480	0160-3456
A11C42	0160-2055	9		CAPACITOR-FXD .01F +80-20% 100VDC CER	28480	0160-2055
A11C43	0160-3431	7		CAPACITOR-FXD 6.8PF +-5PF 500VDC CER	28480	0160-3431
A11C44	0140-0194	1		CAPACITOR-FXD 110PF +-5% 300VDC CER	72136	DM15F111J0300WV1CR
A11C45	0121-0036	0		CAPACITOR-V TRMR-CER 5.5-18PF 350V	52763	304324 5.5/18PF NPO
A11C46	0160-4084	8		CAPACITOR-FXD .1UF4-20% 50VDC CER	28480	0160-4084
A11C47	0160-2055	9		CAPACITOR-FXD .01UF +80-20 100VDC CER	28480	0160-2055
A11C48	0160-2055	9		CAPACITOR--FXD .01UF +80-20% 100VDC CER	284B0	0160-2055
A11C49	0160-2055	9		CAPACITOR-FXD .01UF +80-20% 100VDC CER	28480	0160-2055
A11C50	0160-2055	9		CAPACITOR-FXD .01UF +80-20% 100VDC CER	28480	0160-2055
A11C51	0160-2055	9		CAPACITOR-FXD .01UF +80-20% 100VDC CER	28480	0160-2055
A11C52	0160-2055	9		CAPACITOR--FXD .01UF +80-2.0% 100VDC CER	28480	0160-2055
A11C53	0160-2055	9		CAPACITOR-FXD .01UF +80-20% 100VDC CER	28480	0160-2055
A11C54	0121-0446	6		CAPACITOR-V TRMR-CER 4.5-20PF 160V	28480	0121-0446(
A11C55	0160-2055	9		CAPACITOR-FXD .01UF +80-20% 100VDC CER	28480	0160-2055
A11C56THRU						
A11C59				NOT ASSIGNED		
A11C60	0160-2055	9		CAPACITOR--FXD .01UF +80-20% 10VDC CER	28480	0160-2055
A11C61	0160-2055	9		CAPACITOR-FXD .01UF +80-20% 100VDC CER	28480	0160-2055
A11C62	0160-2055	9		CAPACITOR-FXD .01UF +80-20% 100VDC CER	28480	0160-2055
A11C63	0160-2055	9		CAPACITOR-FXD .01UF +80-20% 100VDC CER	28480	0160-2055
A11C64	0160-2208	4	1	CAPACITOR-FXD 330PF +-5% 300VDC MICA	28480	0160-2208
A11C65	0160-2055	9		CAPACITOR-FXD .01UF +80-20% 100VDC CER	28480	0160-2055
A11C66	0160-2055	9		CAPACITOR-FXD .01UF +50-20% 100VDC CER	28480	0160-2055
A11C67	0160-2055	9		CAPACITOR-FXD .01UF +80-20% 100VDC CER	28480	0160-2055
A11C68THRU						
A11C72				NOT ASSIGNED		
A11C73	0121-0452	4	4	CAPACITOR-V TRMR-AIR 1.3-5.4PF 175V	74970	187-0103-028
A11C74	0121-0452	4		CAPACITOR-V TRMR-AIR 1.3-5.4PF 175V	74970	187-0103-028
A11CR1	1901-0047	8	13	DIODE-SWITCHING 20V 75MA 10NS	28480	1901-0047
A11CR2	1901-0047	8		DIODE-SWITCHING 20V 75MA 10NS	28480	1901-0047
A11CR3	1901-1070	9		DIODE-PIN 110V	28480	1901-1070
A11CR4	1901-1070	9		DIODE-PIN 110V	28480	1901-1070
A11CR5	1901-1070	9		DIODE-PIN 110V	28480	1901-1070
A11CR6	1901-0535	9		DIODE-SM SIG SCHOTTKY	28480	1901-0535
A11CR7				NOT ASSIGNED		
A11CR8	1901-0535	9		DIODE-SM SIG SCHOTTKY	28480	1901-0535
A11CR9	1901-0047	8		DIODE-SWITCHING 20V 75MA 10NS	28480	1901-0047
A11CR10	1901-0047	8		DIODE-SWITCHING 20V 75MA 10NS	28480	1901-0047
A11CR11	1901-1070	9		DIODE--PIN 110V	28480	1901-1070
A11CR12	1901-1070	9		DIODE-PIN 110V	28480	1901-1070
A11CR13	1901-0047	8		DIODE-SWITCHING 20V 75MA 10NS	28480	1901-0047
A11CR14	1901-0535	9		DIODE-SM SIG SCHOTTKY	28480	1901-0535
A11CR15	1901-0535	9		DIODE-SM SIG SCHOTTKY	28480	1901-0535
A11CR16	1901-0047	8		DIODE-SWITCHING 20V 75HA 10NS	28480	1901-0047
A11CR17	1901-0535	9		DIODE-SM SIG SCHOTTKY	28480	1901-0535
A11E1 THRU						
A11E8	9170-0029	3		CORE-SHIELDING BEAD	28480	9170-0029
A11L1	9140-0112	2	3	INDUCTOR RF-CH-MLD 4.7UH 10%	28480	9140-0112
A11L2	9100-1641	0	4	INDUCTOR RF-CH-MLD 240UH 5% .166DX.385LG	28480	9100-1641
A11L3	9140-0114	4	7	INDUCTOR RF-CH-MLD 10UH 10% .166DX.385LG	28480	9140-0114
A11L4	9100-1624	9	6	INDUCTOR RF-CH-MLD 30UH 5% 166DX.385LG	28480	9100-1624
A11L5	9140-0179	1	14	INDUCTOR RF-CH-MLD 22UH 10% .166DX .385LG	28480	9140-0179
A11L6	9100-3854	1	4	INDUCTOR 400NH 10% .3DX1 .016LG Q =150	28480	9100-3854
A11L7	9140-0098	3	4	INDUCTOR RF-CH-MLD 2.2UH 10	28480	9140-0098
A11L8	9140-0178	0		INDUCTOR RF-CH-MLD 12UH 10% .166DX.385LG	28480	9140-0178
A11L9	9100-1641	0		INDUCTOR RF-CH-MLD 240UH 5% .166DX.385LG	28480	9100-1641
A11L10	9140-0114	4		INDUCTOR RF-CH-MLD 10UH 10% .166DX .385LG	28480	9140-0114
A11L11	9100-1624	9		INDUCTOR RF-CH-MLD 30UH 5% .166DX. 385LG	28480	9100-1624
A11L12	9140-0179	1		INDUCTOR RF-CH-MLD 22UH 10% .166DX.385LG	28480	9140-0179
A11L13	9140-0098	3		INDUCTOR RF-CH-MLD 2.2UH 10%	28480	9140-0098
A11L14	9100-1620	5	2	INDUCTOR RF-CH-MLD 15UH 10% .166DX385LG	28480	9100-1620
A11L15	9100-3854	1		INDUCTOR 400NH 10% .3DX1. .016LG Q=150	28480	9100-3854
A11L16	9140-0144	0	3	INDUCTOR RF-CH-MLD 4.7UH 10% .185 DX.26LG	28480	9140-0144
A11L17	9100-1624	9		INDUCTOR RF-CH-MLD 30UH 5% .1.6DX.385LG	28480	9100-1624
A11MP1	08565-00024	2	2	BAFFLE, INDUCTOR	28480	08565-00024
A11Q1	1854-0345	8	1	TRANSISTOR NPN 2N5179 SI TO-72 PD=200MW	04713	2N5179
A11Q2	1854-0404	0		TRANSISTOR NPN SI TO-18 PD=360MW	28480	1854-0404
A11Q3	1853-0007	7		TRANSISTOR PNP 2N3251 SI TO-18 PD=360MW	04713	2N3251
A11Q4	1853-0007	7		TRANSISTOR PNP 2N3251 SI TO-18 PD=360MW	04713	2N3251
A11Q5	1855-0267	5	4	TRANSISTOR J-FET N-CHAN 0-MODE TO-92 SI	28480	1855-0267

See introduction to this section for ordering information
 *Indicates factory selected value

Table 6-3. Replaceable Parts

Reference Designation	HP Part Number	C D	Qty	Description	Mfr. Code	Mfr Part Number
A11Q6	1853-0007	7		TRANSISTOR PNP 2N3251 SI TO-18 PD=360MW	04713	2N3251
A11Q7	1854-0404	0		TRANSISTOR NPN SI TO-18 PD=360MW	28480	1854-0404
A11RQ8	1853-0007	7		TRANSISTOR PNP 2N3251 SI TO-18 PD=360MW	04713	2N3251
A11Q9	1855-0267	5		TRANSISTOR J-FET N-CHAN D-MODE TO-92 SI	28480	1855-0267
A11Q10	1853-0007	7		TRANSISTOR PNP 2N3251 SI TO-18 PD=360MW	04713	2N3251
A11R1	0757-0444	1		RESISTOR 12.1K 1% .125W F TC=0-100	24546	C4-1/8-TO-1212-F
A11R2	0698-3156	2		RESISTOR 14.7K 1% .125W F TC=0+-100	24546	C4-1/8-TO-1472-F
A11R3	0757-0402	1	6	RESISTOR 110 1% .125W F TC=0+-100	24546	C4-1/8-TO-111-F
A11R4				NOT ASSIGNED		
A11R5	0757-0405	4	2	RESISTOR 162 1% .125W F TC=0+-100	24546	C4-1/8-TO-162R-F
A11R6	0698-3431	6	2	RESISTOR 23.7 1% .125W F TC=+-100	03888	PME55-1/8-TO-237R-F
A11R7	0698-8822	9	1	RESISTOR 6.81 1% .1251W F TC=0+-100	28480	0698-8822
A11R8	0757-0401	0		RESISTOR 100 1% .125W F TC=0+-100	24546	C4-1/8-TO-101-F
A11R9	0757-0439	4		RESISTOR 6.81K 1% .125W F TC=0+-100	24546	C4-1/8-TO-6811-F
A11R10	0757-1094	9		RESISTOR 1.47K 1% .125W F TC=0+-100	24546	C4-1/8-TR-1471-F
A11R11	0757-0440	7		RESISTOR 7.5K 1% .125W F TC=0+-100	24546	C4-1/8-TO-7501-F
A11R12	0757-0447	4		RESISTOR 16.2K 1% .125W F TC=0+-100	24546	C4-1/8-TO-1622-F
A11R13	0698-0082	7	1	RESISTOR 464 1% .125W F TC=0+-100	24546	C4-1/8-TO-4640-F
A11R14	0757-0346	2		RESISTOR 10 1% .125W F TC=0+-100	24546	C4-1/8-TO-10R0-F
A11R15	0698-3440	7	9	RESISTOR 196 1% .125W F TC=0+-100	24546	C4-1/8-TO-196R-F
A11R16	0757-0419	0		RESISTOR 681 1% .125W F TC=D+-100	24546	C4-1/8-TO-681R-F
A11R17	0698-3442	9		RESISTOR 237 1% .125W F TC=0+-100	24546	C4-1/8-TO-237R-F
A11R18	0757-0279	0		RESISTOR 3.16K 1% .125W F TC=0+-100	24546	C4-1/8-TO-3161--F
A11R19	0757-0279	0		RESISTOR 3.16K 1% .125W F TC=0+-100	24546	C4-1/8-TO-3161-F
A11R20	0757-0442	9		RESISTOR 10K 1% .125W F TC=D+-100	24546	C4-1/8-TO-1002-F
A11R21	0757-0442	9		RESISTOR 11K 1% .125W F TC=0+-100	24546	C4-1/8-TO-1002-F
A11R22	0757-0442	9		RESISTOR 10K 1% .125W F TC=0+-100	24546	C4-1/8-TO-1002-F
A11R23*	0757-0289	2	14	RESISTOR 13.3K 1% .125W F TC=0+-100	19701	MS4C1/8-TO-1332F
A11R24	0757-0465	6		RESISTOR 100K 1% .125W F TC=0+-100	24546	C4-1/8-TO-1003-F
A11R25	0757-0465	6		RESISTOR 100K 1% .125W F TC=0+-100	24546	C4-1/8-TO-1003-F
A11R26	2100-3163	8	2	RESISTOR-TRMR 1M 20% C SIDE--ADJ 17-TRN	02111	43P105
A11R27	0757-0444	1		RESISTOR 12.1K 1% .125W F TC=0+-1R0	24546	C4-1/8-TO-1212-F
A11R28	0757-0290	5		RESISTOR 6.19K 1% .125W F TC=0+-100	19701	MF4C1/8-TO-6191-F
A11R29	0757-1094	9		RESISTOR 1.47K 1% .125W F TC=0+-100	24546	C4-1/8-TO-1471-F
A11R30	0757-0402	1		RESISTOR 110 1% .125W F TC=0 +-100	24546	C4-1/8-TO-111-F
A11R31	2100-3052	4		RESISTOR-TRMR 50 10% C SIDE--ADJ 17-TRN	02111	43P500
A11R32				NOT ASSIGNED		
A11R33	0757-0442	9		RESISTOR 11K 1% .125W F TC=0+-100	24546	C4-1/8-TO-1002-F
A11R34	0757-0199	3		RESISTOR 21.5K 1X .125W F TC=0+-100	24546	C4-1/8-TO-2152-F
A11R35	0757-0288	1	5	RESISTOR 9.09K 1% .125W F TC=0+-100	19701	MF4C1/8-TO-9091-F
A11R36	0698-0083	0		RESISTOR 1.96K 1% .125W F TC=0+-100	24546	C4-1/8-TO-1961-F
A11R37	0757-0416	7		RESISTOR 511 1% .125W F TC=0+-100	24546	C4-1/8-TO-511R-F
A11R38	0698-3441	8	3	RESISTOR 215 1% .125W F TC=0+-100	24546	C4-1/8-TO-215R-F
A11R39	0757-0419	0		RESISTOR 681 1% .125W F TC=0+-100	24546	C4-1/8-TO-681R-F
A11R40	0698-3442	9		RESISTOR 237 1% .125W F TC=0+-100	24546	C4-1/8-TO-237R-F
A11R41	0757-0279	0		RESISTOR 3.16K 1% .125W F TC=0+-100	24546	C4-1/8-TO-3161-F
A11R42	0757-0442	9		RESISTOR 10K 1% .125W F TC=0+-100	24546	C4. 1/8-TO-1002-F
A11R43*	0757-0200	7	4	RESISTOR 5.62K 1% .125W F TC=0+-100	24546	C4-1/8-TO-5621-F
A11R44	0757-0442	9		RESISTOR 10K 1% .125W F TC=0+-100	24546	C4-1/8-TO-1002-F
A11R45	0757-0401	0		RESISTOR 100 1% .125W F TC=0+-100	24546	C4-1/8-TO-101-F
A11R46	0757-0401	0		RESISTOR 100 1% .125W F TC=0+-100	24546	C4-1/8-TO-101-F
A11R47	0757-0346	2		RESISTOR 10 1% .125W F TC=0+-100	24546	C4-1/8-TO-10R0-F
A11R48*	0698-3156	2		RESISTOR 14.7K 1% .125W F TC=0+-100	24546	C4-1/8-TO-1472-F
A11R49	0757-0444	1		RESISTOR 12.1K 1% .125W F TC=0+-110	24546	C4-1/8TO-1212-F
A11R50				NOT ASSIGNED		
A11R51	0757-0346	2		RESISTOR 10 1% .125W F TC=0+-100	24546	C4-1/8 -TO-10R0-F
A11R52	0757-0290	5		RESISTOR 6.19K 1% .125W F TC=0+-100	19701	MF4C1/8STD-6191-F
A11R53	0698-3440	7		RESISTOR 196 1% .125W F TC=0+-110	24546	C4-1/8-TO-196R-F
A11R54	0757-0416	7		RESISTOR 511 1% .125W F TC=0+-100	24546	C4-1/8-TO-511R--F
A11R55	0757-0442	9		RESISTOR 10K 1% .125W F TC=0+-10	24546	C4-1/8-TO-1002-F
A11R56*	0757-0424	7		RESISTOR 1.1K 1% .125W F TC=0+-100	24546	C4-1/8-TO-1101-F
A11R57	0757-0180	2	6	RESISTOR 31.6 1x .125W F TC=0+-100	28480	0757-0180
A11R58	0698-3152	8		RESISTOR 3.48K 1% .125W F TC=0+-100	24546	C4-1/8-TO-3481-F
A11R59	0757-0180	2		RESISTOR 31.6 1% .125W F TC=0+-100	28480	0757-0180
A11R60	0698-3153	9		RESISTOR 3.83K 1% .125W F TC=0+-100	24546	C4-1/8-TO-3831-F
A11TP1	0360-1788	7	8	CONNECTOR-SGL CONT PIN .045-IN-BSC-SZ SQ	28480	0360-1788
A11TP2	0360-1788	7		CONNECTOR-SGL CONT PIN .045-IN-BSC-SZ SQ	28480	0360-1788
A11TP3	1251-0600	0		CONNECTOR-SGL CONT PIN 1.14-MM-BSC-SZ S0	28480	1251-0600
A11TP4	0360-1788	7		CONNECTOR-SGL CONT PIN .045-IN-BSC-SZ SQ	28480	0360-1788
A11TP5	0360-1788	7		CONNECTOR-SGL CONT PIN .045-IN-BSC-SZ S	28480	0360-1788
A11TP6	1251-0600	0		CONNECTOR-SGL- CONT PIN 1.14-MM-BSC-SZ SQ	28480	1251-0600
A11TP7				NOT ASSIGNED		
A11TP8	1251-0600	0		C10CONNECTOR-SGL CONT PIN 1.14-MM-BSC-SZ SQ	28480	1251-0600
A11TP9	1251-0600	0		CONNECTOR-SGL CONT PIN 1.14-MM-BSC-SZ SQ	28480	1251-0600
A11TP10	1251-0600	0		CONNECTOR-SGL CONT PIN 1.14-MM-BSC-SZ SQ	28480	1251-0600

See introduction to this section for ordering information
 *Indicates factory selected value

Table 6-3. Replaceable Parts

Reference Designation	HP Part Number	C D	Qty	Description	Mfr. Code	Mfr Part Number
A11TP1	1251-0600	0		CONNECTOR-SGL CONT PIN 1,14-MM-BSC-SZ SQ	28480	1251-0600
A11VR1	1902-0048	1	2	DIODE-ZNR 6.81V 5% DO-35 PD= 4W	28480	1902-0048
A11Y1/2	0410-0450	5	2	CRYSTAL, 21.4 MHZ (MATCHED SET OF FOUR; INCLUDES A11Y1, A11Y2, A13Y1, & A13Y2)	28480	0410-0450
A12	08558-60012	5	1	STEP GAIN	28480	08558-60012
A12	08558-60073	8		STEP GAIN, OPTION 001/002	28480	08558-60073
A12C1	0160-2055	9		CAPACITOR-FXD .01UF +80-20% 100VDC CER	28480	0160-2055
A12C2	0160-2055	9		CAPACITOR-FXD .01UF +80-20% 100VDC CER	28480	0160-2055
A12C3	0160-2055	9		CAPACITOR-FXD .01UF +80-20% 100VDC CER	28480	0160-2055
A12C4	0160-2055	9		CAPACITOR-FXD .01UF +80-20% 100VDC CER	28480	0160-2055
A12C5	0160-2055	9		CAPACITOR-FXD .01UF +80-20% 100VDC CER	28480	0160-2055
A12C6	0160-2055	9		CAPACITOR-FXD .01UF +80-20% 100VDC CER	28480	0160-2055
A12C7	0160-2055	9		CAPACITOR-FXD .01UF +80-20% 100VDC CER	28480	0160-2055
A12C8	0160-2055	9		CAPACITOR-FXD .01UF +80-20% 100VDC CER	28480	0160-2055
A12C9	0160-2055	9		CAPACITOR-FXD .01UF +80-20% 100VDC CER	28480	0160-2055
A12C10	0160-2055	9		CAPACITOR-FXD .01UF +80-20% 100VDC CER	28480	0160-2055
A12C11	0160-2055	9		CAPACITOR-FXD .01UF +80-20% 100VDC CER	28480	0160-2055
A12C12	0160-2055	3	2	CAPACITOR-FXD 1UF+-10% 35VDC TA	56289	150D105X9035A2
A12C13	0160-2055	9		CAPACITOR-FXD .01UF +80-20% 100VDC CER	28480	0160-2055
A12C14	0160-2055	9		CAPACITOR-FXD .01UF +80-20% 100VDC CER	28480	0160-2055
A12C15	0160-2055	9		CAPACITOR-FXD .01UF +80-20% 100VDC CER	28480	0160-2055
A12C16	0160-2055	9		CAPACITOR-FXD 2000PF +-10% 250VDC CER	28480	0160-3457
A12C17	0160-2055	9		CAPACITOR-FXD .01UF +80-20% 100VDC CER	28480	0160-2055
A12C18	0160-2055	9		CAPACITOR-FXD .01UF +80-20% 100VDC CER	28480	0160-2055
A12C19	0160-2055	9		CAPACITOR-FXD 2000PF +-10% 250VDC CER	28480	0160-3457
A12C20	0160-2055	9		CAPACITOR-FXD .01UF +80-20% 100VDC CER	28480	0160-2055
A12C21	0160-2055	9		CAPACITOR-FXD 01UF +80-20% 100VDC CER	28480	0160-2055
A12C22	0160-2055	9		CAPACITOR-FXD 2000PF +-10% 250VDC CER	28480	0160-3457
A12C23	0160-2055	9		CAPACITOR-FXD .01UF +80-20% 100VDC CER	28480	0160-2055
A12C24	0160-2199	2	1	CAPACITOR-FXD 30PF +-5% 300VDC MICA	28480	0160-2199
A12C25	0160-2307	4	1	CAPACITOR-FXD 47PF +-5% 300VDC MICA	28480	0160-2307
A12C26	0140-0194	1		CAPACITOR-FXD 110PF +-5% 300VDC MICA	72136	DM15F111J0300WV1CR
A12C27	0180-0291	3		CAPACITOR-FXD 1UF+-10% 35VDC TA	56209	150D105X9035A2
A12CR1	1901-0050	3		DIODE-SWITCHING 80V 200MA 2NS DO-35	28480	1901-0050
A12CR2	1901-0050	3		DIODE-SWITCHING 80V 200MA 2NS DO-35	28480	1901-0050
A12CR3	1901-1070	9		DIODE-PIN 110V	28480	1901-1070
A12CR4	1901-1070	9		DIODE-PIN 110V	28480	1901-1070
A12CR5	1901-1070	9		DIODE-PIN 110V	28480	1901-1070
A12CR6	1901-1070	9		DIODE-PIN 110V	28480	1901-1070
A12E1	9170-0029	3		CORE-SHIELDING BEAD	28480	9170-0029
A12E2	9170-0029	3		CORE-SHIELDING BEAD	28480	9170-0029
A12E3	9170-0029	3		CORE-SHIELDING BEAD	28480	9170-0029
A12L1	9140-0179	1		INDUCTOR RF-CH-MLD 22UH 10% .166DX.385LG	28480	9140-0179
A12L2	9140-0179	1		INDUCTOR RF-CH-MLD 22UH 10% .166DX.385LG	28480	9140-0179
A12L3	9140-0179	1		INDUCTOR RF-CH-MLD 22UH 10% .166DX.385LG	28480	9140-0179
A12L4	9140-0179	1		INDUCTOR RF-CH-MLD 22UH 10% .166DX.385LG	28480	9140-0179
A12L5	9140-0179	1		INDUCTOR RF-CH-MLD 22UH 10% .166DX.385LG	28480	9140-0179
A12L6	9140-0179	1		INDUCTOR RF-CH-MLD 22UH 10% .166DX.385LG	28480	9140-0179
A12L7	9140-0179	1		INDUCTOR RF-CH-MLD 22UH 10% .166DX.385LG	28480	9140-0179
A12L8	9140-0179	1		INDUCTOR RF-CH-MLD 22UH 10% .166DX.385LG	28480	9140-0179
A12L9	9100-2260	1		INDUCTOR RF-CH-MLD 1.8UH 10% .105DX.26LG	28480	9100-2260
A12L10	9140-0158	6	5	INDUCTOR RF-CH-MLD 1UH 10% .105DX.26LG	28480	9140-0158
A12L11	9100-2552	4	4	INDUCTOR RF-CH-MLD 15UH 10% .161DX.385LG	28480	9100-2552
A12Q1	1853-0007	7		TRANSISTOR PNP 2N3251 SI TO-18 PD=360MW	04713	2N3251
A12Q2	1854-0345	8		TRANSISTOR NPN 2N5179 SI TO-72 PD=200MW	04713	2N5179
A12Q3	1853-0007	7		TRANSISTOR PNP 2N3251 SI TO-18 PD=360MW	04713	2N3251
A12Q4	1854-0345	8		TRANSISTOR NPN 2N5179 SI TO-72 PD=200MW	04713	2N5179
A12Q5	1853-0007	7		TRANSISTOR PNP 2N3251 SI TO-18 PD=360MW	04713	2N3251
A12Q6	1854-0345	8		TRANSISTOR NPN 2N5179 SI TO-72 PD=200MW	04713	2N5179
A12Q7	1853-0007	7		TRANSISTOR PNP 2N3251 SI TO-18 PD=360MW	04713	2N3251
A12Q8	1853-0007	7		TRANSISTOR PNP 2N3251 SI TO-18 PD=360MW	04713	2N3251
A12Q9	1853-0007	7		TRANSISTOR PNP 2N3251 SI TO-18 PD=360MW	04713	2N3251
A12Q10	1854-0882	8		TRANSISTOR NPN PD=300MW FT=200MHZ	28480	1854-0882
A12Q11	1854-0882	8		TRANSISTOR NPN PD=300MW FT=200MHZ	28480	1854-0882
A12Q12	1853-0007	7		TRANSISTOR PNP 2N3251 SI TO-18 PD=360MW	04713	2N3251
A12Q13	1853-0213	7	1	TRANSISTOR PNP 2N4236 SI TO-5 PD=1W	04713	2N4236
A12R1	2100-3103	6	3	RESISTOR-TRMR 10K 10% C SIDE-ADJ 17-TRN	02111	43P103
A12R2	2100-3103	6		RESISTOR-TRMR 10K 10% C SIDE-ADJ 17-TRN	02111	43P103
A12R3	2100-3054	6	1	RESISTOR-TRMR 50K 10% C SIDE-ADJ 17-TRN	02111	43P503
A12R4	2100-3061	5	1	RESISTOR-TRMR 500K 10% C SIDE-ADJ 17-TRN	02111	43P504
A12R5	2100-3103	6		RESISTOR-TRMR 10K 10% C SIDE-ADJ 17-TRN	02111	43P103

See introduction to this section for ordering information

*Indicates factory selected value

Table 6-3. Replaceable Parts

Reference Designation	HP Part Number	C D	Qty	Description	Mfr. Code	Mfr Part Number
A12R6	2100-3056	8	1	RESISTOR-TRMR 5K 10% C SIDE-ADJ 17-TRN	02111	43P502
A12R7	2100-1757	2		RESISTOR-TRMR 500 5% WW SIDE-ADJ 1-TRN	28480	2100-1757
A12R8	0757-0288	1		RESISTOR 9.09K 17 .125W F TC=0+-100	19701	MF4C1/8-TO-9091-F
A12R9	0698-3457	6		RESISTOR 316K 1% .125W F TC=0+-100	213480	0698-3457
A12R10	0757-0346	2		RESISTOR 10 1% .125W F TC=0+-100	24546	C4-1/8-TO-10R0-F
A12R11	0757-0279	0		RESISTOR 3.16K 1% .125W F TC=0+-100	24546	C4-1/8-TO-3161-F
A12812	0698-3444	1		RESISTOR 316 1% .125W F TC=0+-100	24546	C4-1/8-TO-316R-F
A12R13	0757-0208	1		RESISTOR 9.09K 1% .125W F TC=0+-100	19701	MF4C1/8-TO-9091-F
A12R14	0757-0395	1	5	RESISTOR 56.2 1% .125W F TC=0+-100	24546	C4-1/8-TO-56R2-F
A12R15	0757-0346	2		RESISTOR 10 1% .125W F TC=0+-100	24546	C4-1/8-TO-10R0-F
A12R16	0757-0346	2		RESISTOR 10 1% .125W F TC=0+-100	24546	C4-1/8-TO-10R0-F
A12R17	0757-0290	5		RESISTOR 6.19K 1% .125W F TC=0+-100	19701	MF4C1/8-TO-6191-F
A12R18	0757-0346	2		RESISTOR 10 1% .125W F TC=0+-100	24546	C4-1/8-TO-10R0-F
A12R19	0757-0290	5		RESISTOR 6.19K 1% .125W F TC=0+-100	19701	MF4C1/8-TO-6191-F
A12R20	0757-0279	0		RESISTOR 3.16K 1x .125W F TC=0+-100	24546	C4-1/8-TO-3161-F
A12R21	0698-3162	0		RESISTOR 46.4K 11 .125W F TC=0+-100	24546	C4-1/8-TO-4642-F
A12R22	0757-0279	0		RESISTOR 3.16K 1% .125W F TC=0+-100	24546	C4-1/8-TO-3161-F
A12R23	0698-3444	1		RESISTOR 316 1% .125W F TC=0+-100	24546	C4-1/8-TO-316R-F
A12824	0757-0395	1		RESISTOR 56.2 17 .125W F TC=0+-100	24546	C4-1/8-TO-56R2-F
A12R25	0757-0280	3		RESISTOR 1K 11 .125W F TC=0+-108	24546	C4-1/8-TO-1001-F
A12R26	0757-0417	8	2	RESISTOR 562 1% .125W F TC=0+-100	24546	C4-1/8-TO-562R-F
A12R26	0757-0419	0		RESISTOR 681 1% .125W F TC=0+-100 (OPTION 001/002)	24546	C4-1/8-TO-681R-F
A12827	0757-0280	3		RESISTOR 1K 1% .125W F TC=0+-100	24546	C4-1/8-TO-1001-F
A12R28	0757-0279	0		RESISTOR 3.16K 1% .125W F C=0+-100	24546	C4-1/8-TO-3161-F
A12R29	0690-3444	1		RESISTOR 316 1% .125W F TC=0+-100	24546	C4-1/8-TO-316R-F
A12R30	0757-0395	1		RESISTOR 56.2 1% .125W F TC=0+-100	24546	C4-1/8-TO-56R2-F
A12R31	0757-0280	3		RESISTOR 1K 1% .125W F TC=0+-100	24546	C4-1/8-TO-1001-F
A12R32	0757-0420	3		RESISTOR 750 1% .125W F TC=0+-100	24546	C4-1/8-TO-751-F
A12R33	0757-0280	3		RESISTOR 1K 1% .125W F TC=0+-100	24546	C4-1/8-TO-1001-F
A12R34	0757-0279	0		RESISTOR 3.16K 1% .125W F TC=0+-100	24546	C4-1/8-TO-3161-F
A12R35	0698-3444	1		RESISTOR 316 1X .125W F TC=0+-100	24546	C4-1/8-TO-316R-F
A12R36	0757-0395	1		RESISTOR 56.2 1% .125W F TC=0+-100	24546	C4-1/8-TO-56R2-F
A12R37	0757-0280	3		RESISTOR 1K 1% .125W F TC=0+-100	24546	C4-1/8-TO-1001-F
A12R38	0757-0420	3		RESISTOR 750 1% .125W F TC=0+-100	24546	C4-1/8-TO-751-F
A12R39	0757-0280	3		RESISTOR 1K 1% .125W F TC=0+-100	24546	C4-1/8-TO-1001-F
A12R40	0698-3440	7		RESISTOR 196 1% .125W F TC=0+-100	24546	C4-1/8-TO-196R-F
A12R41	0757-0274	5		RESISTOR 1.21K 1% .125W F TC=0+-100	24546	C4-1/8-TO-1211-F
A12R42	0757-0274	5		RESISTOR 1.21K 1% .125W F TC=0+-100	24546	C4-1/8-TO-1211-F
A12R43	0698-3151	7		RESISTOR 2.87K 1% .125W F TC=0+-100	24546	C4-1/8-TO-2071-F
A12R44	0698-3151	7		RESISTOR 2.87K 1% .125W F TC=0+-100	24546	C4-1/8-TO-2871-F
A12R45	0757-0290	5		RESISTOR 6.19K 1% .125W F TC=0+-100	19701	MF4C1/8-TO-6191-F
A12R46	0698-3151	7		RESISTOR 2.87K 1% .125W F TC=0+-100	24546	C4-1/8-TO-2871-F
A12R47	0698-3162	0		RESISTOR 46.4K 1% .125W F TC=0+-100	24546	C4-1/8-TO-4642-F
A12R48	0698-3162	0		RESISTOR 46.4K 1% .125W F TC=0+-100	24546	C4-1/8-TO-4642-F
A12R49	0698-3162	0		RESISTOR 46.4K 1% .125W F TC=0+-100	24546	C4-1/8-TO-4642-F
A12S1	3101-0973	5	1	SWITCH-SL DPDT MINTR .5A 125VAC/DC PC	28480	3101-0973
A12TP1 THRU						
A12TP9	1251-0600	0		CONNECTOR-SGL CONT PIN 1.14-MM-BSC-SZ SQ	28480	1251-0600
A12VR1	1902-0033	4		DIODE-ZNR 1N823 6.2V 5% DO-7 PD=.4W	24046	1N823
A13	08558-60129	5	1	BANDWIDTH FILTER NO. 2	28480	08558-60129
A13C1	0160-2055	9		CAPACITOR-FXD .01UF +80-20% 100VDC CER	28480	0160-2055
A13C2	0160-0127	2		CAPACITOR-FXD 1UF +-20% 25VDC CER	28480	0160-0127
A13C3	0160-2236	8		CAPACITOR-FXD 1PF +-25PF 500VDC CER	28480	0160-2236
A13C4	0160-2055	9		CAPACITOR-FXD .01UF +80-20% 100VDC CER	28480	0160-2055
A13C5	0160-2055	9		CAPACITOR-FXD .01UF +80-20% 100VDC CER	28480	0160-2055
A13C6	0160-2055	9		CAPACITOR-FXD .01UF +80-20% 100VDC CER	28480	0160-2055
A13C7	0160-2055	9		CAPACITOR-FXD .01UF +80-20% 100VDC CER	28480	0160-2055
A13C8	0160-2207	3		CAPACITOR-FXD 300PF +5% 300VDC MICA	28480	0160-2207
A13C9	0160-2055	9		CAPACITOR-FXD .01UF +80-20% 100VDC CER	28480	0160-2055
A13C10	0160-2055	9		CAPACITOR-FXD .01UF +80-20% 100VDC CER	28480	0160-2055
A13C11	0160-2055	9		CAPACITOR-FXD .01UF +80-20% 100VDC CER	28480	0160-2055
A13C12	0160-2055	9		CAPACITOR-FXD .01UF +80-20% 100VDC CER	28480	0160-2055
A13C13	0160-3456	6		CAPACITOR-FXD 1000PF +-10% 1KVDC CER	28480	0160-3456
A13C14	0160-2250	6		CAPACITOR-FXD 5.1PF +-25PF 500VDC CER	28480	0160-2250
A13C15	0121-0059	7		CAPACITOR-V TRMR-CER 2-8PF 350V PC-MTG	52763	304324 2/8PF NPO
A13C16				NOT ASSIGNED		
A13C17	0160-2055	9		CAPACITOR-FXD .01UF +80-20% 100VDC CER	28480	0160-2055
A13C18	0160-2055	9		CAPACITOR-FXD .01UF +80-20% 100VDC CER	28480	0160-2055
A13C19	0160-2055	9		CAPACITOR-FXD .01UF +80-20% 100VDC CER	28480	0160-2055
A13C20*	0140-0194	1		CAPACITOR-FXD 110PF +5% 300VDC MICA	72136	DM15F111J0300WV1CR

See introduction to this section for ordering information

*Indicates factory selected value

Table 6-3. Replaceable Parts

Reference Designation	HP Part Number	C D	Qty	Description	Mfr. Code	Mfr Part Number
A13C21	0160-3431	7		CAPACITOR-FXD 6.8PF +- .5PF 500VDC CER	28480	0160-3431
A13C22	0160-4084	8		CAPACITOR-FXD .1UF +-20% 50VDC CER	28480	0160-4084
A13C23	0121-0036	0		CAPACITOR-V TRMR-CER 5.5-18PF 350V	52763	304324 5.5/18PF NPO
A13C24				NOT ASSIGNED		
A13C25	0121-0446	6		CAPACITOR-V TRMR-CER 4.5-20PF 160V	28480	0121-0446
A13C26	0160-2055	9		CAPACITOR-FXD .01UF +80-20x 100VDC CER	28480	0160--2055
A13C27	0160-2055	9		CAPACITOR-FXD .01UF +80-20% 100VDC CER	28480	0160-2055
A13C28	0160-2055	9		CAPACITOR-FXD .01UF +80-20% 100VDC CER	28480	0160-2055
A13C29	0160-3456	6		CAPACITOR-FXD 1000PF +-10% 1KVDC CER	28480	0160-3456
A13C30	0160-2055	9		CAPACITOR-FXD .01UF +80-20% 100VDC CER	28480	0160-2055
A13C31	0160-3456	6		CAPACITOR-FXD 1000PF +-10% 1KVDC CER	28480	0160-3456
A13C32	0160-4084	8		CAPACITOR-FXD .1UF +-20% 50VDC CER	28480	0160-4084
A13C33	0160-2207	3		CAPACITOR-FXD 300PF +-5% 300VDC MICA	28480	0160-2207
A13C34	0160-2055	9		CAPACITOR-FXD .01UF +80-20% 100VDC CER	28480	0160-2055
A13C35	0160-2055	9		CAPACITOR-FXD .01UF +80-20% 100VDC CER	28480	0160-2055
A13C36	0160-2055	9		CAPACITOR-FXD .01UF +80-20% 100VDC CER	20480	0160-2055
A13C37	0160-2250	6		CAPACITOR-FXD 5.1PF +- .25PF 500VDC CER	28480	0160-2250
A13C38	0121-0059	7		CAPACITOR-V TRMR-CER 2-8PF 350V PC-MTG	52763	304324 2/8PF NPO
A13C39				NOT ASSIGNED		
A13C40	0160-2055	9		CAPACITOR-FXD .01UF +80-20% 100VDC CER	28480	0160-2055
A13C41	0160-3456	6		CAPACITOR-FXD 1000PF +- .10% 1KVDC CER	28480	0160-3456
A13C42	0160-2055	9		CAPACITOR-FXD .01UF +80-20% 100VDC CER	20480	0160-2055
A13C43	0160-3431	7		CAPACITOR-FXD 6.8PF +- .5PF 500VDC CER	28480	0160-3431
A13C44*	0140-0194	1		CAPACITOR-FXD 110PF +-5% 300VDC MICA	72136	DM15F111J0300WV1CR
A13C45	0121-0036	0		CAPACITOR-V TRMR-CER 5.5-18PF 350V	52763	304324 5.5/18PF NPO
A13C46	0160-4084	8		CAPACITOR-FXD .1UF +-20% 50VDC CER	28480	0160-4084
A13C47	0160-2055	9		CAPACITOR--FXD .01UF +80-20% 100VDC CER	28480	0160-2055
A13C48	0160-2055	9		CAPACITOR-FXD .01UF +80-20% 100VDC CER	28480	0160-205550
A13C49	0160-2055	9		CAPACITOR-FXD .01UF +80-20% 100VDC CER	28480	0160-2055
A13C50	0160-2055	9		CAPACITOR-FXD .01UF+80-20% 100VDC CER	28480	0160-2055
A13C51	0160-2055	9		CAPACITOR-FXD .01UF +80-20% 100VDC CER	28480	0160-2055
A13C52	0160-2055	9		CAPACITOR-FXD .01UF +80-20% 100VDC CER	28480	0160-2055
A13C53	0160-2055	9		CAPACITOR-FXD .01UF +80-20% 100VDC CER	28480	0160-2055
A13C54	0121-0446	6		CAPACITOR-V TRMR-CER 4.5-20PF 160V	28480	0121-0446
A13C55	0160-2055	9		CAPACITOR-FXD .01UF +80-20% 100VDC CER	28480	0160-2055
A13C56 THRU						
A13C59				NOT ASSIGNED		
A13C60	0160-2055	9		CAPACITOR-FXD .01UF +80-20% 100VDC CER	28480	0160-2055
A13C61	0160-2055	9		CAPACITOR-FXD .01UF +80-20% 100VDC CER	28480	0160-2055
A13C62	0160-2055	9		CAPACITOR-FXD .01UF +80-20% 100VDC CER	28480	0160-2055
A13C63	0160-2055	9		CAPACITOR-FXD .01UF +80-20% 100VDC CER	28480	0160-2055
A13C64	0160-2055	9		CAPACITOR-FXD .01UF +80-20% 100VDC CER	28480	0160-2055
A13C65	0160-2055	9		CAPACITOR-FXD .01UF +80-20% 100VDC CER	28480	0160-2055
A13C66	0160-2055	9		CAPACITOR-FXD .01UF +80-20% 100VDC CER	28480	0160-2055
A13C67	0160-2055	9		CAPACITOR-FXD .01UF +80-20% 100VDC CER	28480	0160-2055
A13C68 THRU						
A13C72				NOT ASSIGNED		
A13C73	0121-0452	4		CAPACITOR-V TRMR-AIR 1.3-5.4PF 175V	74970	187-0103-028
A13C74	0121-0452	4		CAPACITOR-V TRMR-AIR 1.3-5.4PF 175V	74970	187-0103-028
A13CR1	1901-0047	8		DIODE-SWITCHING 20V 75MA 10NS	28480	1901-0047
A13CR2	1901-0047	8		DIODE-SWITCHING 20V 75MA 10NS	28480	1901-0047
A13CR3	1901-1070	9		DIODE-PIN 110V	28480	1901-1070
A13CR4	1901-1070	9		DIODE-PIN 110V	28480	1901-1070
A13CR5	1901-1070	9		DIODE-PIN 112V	28480	1901-1070
A13CR6	1901-0535	9		DIODE-SM SIG SCHOTTKY	28480	1901-0535
A13CR7				NOT ASSIGNED		
A13CR8	1901-0535	9		DIODE-SM SIG SCHOTTKY	28480	1901-0535
A13CR9	1901-0047	8		DIODE-SWITCHING 20V 75MA 10NS	28480	1901-0047
A13CR10	1901-0047	8		DIODE-SWITCHING 20V 75MA 10NS	28480	1901-0047
A13CR11	1901-1070	9		DIODE-PIN 110V	28480	1901-1070
A13CR12	1901-1070	9		DIODE-PIN 110V	28480	1901-1070
A13CR13	1901-0047	8		DIODE-SWITCHING 20V 75MA-10NS	28480	1901-0047
A13CR14	1901-0535	9		DIODE-SM SIG SCHOTTKY	28480	1901-0535
A13CR15	1901-0535	9		DIODE-SM SIG SCHOTTKY	28480	1901-0535
A13CR16	1901-0047	8		DIODE-SWITCHING 20V 75MA 10NS	28480	1901-0047
A13CR17	1901-0535	9		DIODE-SM SIG SCHOTTKY	28480	1901-0535
A13CR18	1901-0047	8		DIODE-SWITCHING 20V 75MA 10NS	28480	1901-0047
A13E1	9170-0029	3		CORE-SHIELDING BEAD	28480	9170-0029
A13E2	9170-0029	3		CORE-SHIELDING BEAD	28480	9170-0029
A13E3	9170-0029	3		CORE-SHIELDING BEAD	28480	9170-0029
A13E4	9170-0029	3		CORE-SHIELDING BEAD	28480	9170-0029
A13E5	9170-0029	3		CORE-SHIELDING BEAD	28480	9170-0029
A13E6	9170-0029	3		CORE-SHIELDING BEAD	28480	9170-0029
A13E7	9170-0029	3		CORE-SHIELDING BEAD	28480	9170-0029
A13E8	9170-0029	3		CORE-SHIELDING BEAD	28480	9170-0029

See introduction to this section for ordering information

*Indicates factory selected value

Table 6-3. Replaceable Parts

Reference Designation	HP Part Number	C D	Qty	Description	Mfr. Code	Mfr Part Number
A13L1	9140-0112	2		INDUCTOR RF-CH-MLD 4.7UH 10%	28480	9140-0112
A13L2	9100-1641	0		INDUCTOR RF-CH-MLD 240UH 5% .166DX.385LG	28480	9100-1641
A13L3	9140-0114	4		INDUCTOR RF-CH-MLD 10UH 10% .166DX.385LG	28480	9140-0114
A13L4	9100-1624	9		INDUCTOR RF-CH-MLD 30UH 5% .166DX.385LG	28480	9100-1624
A13L5	9140-0179	1		INDUCTOR RF-CH-MLD 22UH 10% .166DX.385LG	28480	9140-0179
A13L6	9100-3854	1		INDUCTOR 400NH 10% .3DX1.016LG Q=150	28480	9100-3854
A13L7	9140-0098	3		INDUCTOR RF-CH-MLD 2.2UH 10%	28480	9140-0098
A13L8	9140-0178	0		INDUCTOR RF-CH-MLD 12UH 10% .166DX.385LG	28480	9140-0178
A13L9	9100-1641	0		INDUCTOR RF-CH-MLD 240UH 5% .166DX.305LG	28480	9100-1641
A13L10	9140-0114	4		INDUCTOR RF-CH-MLD 10UH 10% .166DX.385LG	28480	9140-0114
A13L11	9100-1624	9		INDUCTOR RF-CH-MLD 30UH 5% .166DX.385LG	28480	9100-1624
A13L12	9140-0179	1		INDUCTOR RF-CH-MLD 22UH 10% .166DX.385LG	28480	9140-0179
A13L13	9140-0098	3		INDUCTOR RF-CH-MLD 2.2UH 10%	28480	9140-0098
A13L14	9100-1620	5		INDUCTOR RF-CH-MLD 15UH 10% .166DX.385LG	28480	9100-1620
A13L15	9100-3854	1		INDUCTOR 400NH 10% .3DX1.016LG Q=150	28480	9100-3854
A13L16	9140-0144	0		INDUCTOR RF-CH-MLD 4.7UH 10% .105DX.26LG	28480	9140-0144
A13L17	9100-1624	9		INDUCTOR RF-CH-MLD 30UH 5% .166DX.385LG	28480	9100-1624
A13MP1	08565-00024	2		BAFFLE, INDUCTOR	28480	08565-00024
A13Q1	1854-0345	8		TRANSISTOR NPN 2N5179 SI TO-72 PD=200MW	04713	2N5179
A15Q2	1854-0404	0		TRANSISTOR NPN SI TO-18 PD=360MW	28480	1854-0404
A13Q3	1853-0007	7		TRANSISTOR PNP 2N3251 SI TO-18 PD=360MW	04713	2N3251
A13Q4	1053-0007	7		TRANSISTOR PNP 2N3251 SI TO-18 PD=360MW	04713	2N5251
A13Q5	1855-0267	5		TRANSISTOR J-FET N-CHAN D-MODE TO-92 SI	28480	1855-0267
A13Q6	1853-0007	7		TRANSISTOR PNP 2N3251 SI TO-18 PD=360MW	04713	2N3251
A13Q7	1854-0404	0		TRANSISTOR NPN SI TO-18 PD=360MW	28480	1854-0404
A13Q8	1853-0007	7		TRANSISTOR PNP 2N3251 SI TO-18 PD=360MW	04713	2N3251
A13Q9	1855-0267	5		TRANSISTOR J-FET N-CHAN D-MODE TO-92 SI	20480	1855-0267
A13Q10	1853-0007	7		TRANSISTOR PNP 2N5251 SI TO-18 PD=360MW	04713	2N3251
A13R1	0757-0447	4		RESISTOR 16.2K 1% .125W F TC=0+-100	24546	C4-1/8-TO-1622-F
A13R2	0698-3157	3	1	RESISTOR 19.6K 1% .125W F TC=0+-100	24546	C4-1/8-TO-1962-F
A13R3	0757-0402	1		RESISTOR 110 1X .125W F TC=0+-100	24546	C4-1/8-TO-111-F
A13R4				NOT ASSIGNED		
A13R5	0757-0405	4		RESISTOR 162 1% .125W F TC=0+-100	24546	C4-1/8-TO-162R-F
A13R6	0698-3431	6		RESISTOR 23.7 1% .125W F TC=0+-100	03888	PME55-1/8-TO-23R7-F
A13R7	0698-3427	0	1	RESISTOR 13.3 1% .125W F TC=0+-100	03888	PME55-1/8-TO-13R3-F
A13R8	0757-0402	1		RESISTOR 110 1% .125W F TC=0+-100	24546	C4-1/8-TO-111-F
A13R9	0757-0288	1		RESISTOR 9.09K 1% .125W F TC=0+-100	19701	MF4C1/8-TO-9091-F
A13R10	0698-0083	8		RESISTOR 1.96K 1% .125W F TC=0+-100	24546	C4-2/8-TO-1961-F
A13011	0757-0442	9		RESISTOR 10K 1% .125W F TC=0+-100	24546	C4-1/8-TO-1002-F
A13R12	0757-0199	3		RESISTOR 21.5K 1% .125W F TC=0+-100	24546	C4-1/8-TO-2152-F
A13R13	0757-0416	7		RESISTOR 511 1% .125W F TC=0+-100	24546	C4-1/8-TO-511R-F
A13R14	0757-0346	2		RESISTOR 10 1% .125W F TC=0+-100	24546	C4-1/8-TO-10R0-F
A13R15	0698-3441	8		RESISTOR 215 1% .125W F TC=0+-100	24546	C4-1/8-TO-215R-F
A13R16	0757-0419	0		RESISTOR 681 1% .125W F TC=0+-100	24546	C4-1/8-TO-681R-F
A13R17	0698-3442	9		RESISTOR 237 1% .125W F TC=0+-100	24546	C4-1/8-TO-237R-F
A13R18	0757-0279	0		RESISTOR 3.16K 1% .125W F TC=0+-100	24546	C4-1/8-TO-3161-F
A13019*	0757-0200	7		RESISTOR 5.62K 1% .125W F TC=0+-100	24546	C4-1/8-TO-5621-F
A13R20	0757-0442	9		RESISTOR 10K 1% .125W F TC=0+-100	24546	C4-1/8-TO-1002-F
A13R21	0757-0442	9		RESISTOR 10K 1% .125W F TC=0+-100	24546	C4-1/8-TO-1002-F
A13R22	0757-0442	9		RESISTOR 10K 1% .125W F TC=0+-100	24546	C4-1/8-TO-1002-F
A13R23*	0698-3156	2		RESISTOR 14.7K 1% .125W F TC=0+-100	24546	C4-1/8-TO-1472-F
A13R24	0757-0465	6		RESISTOR 100K 1% .125W F TC=0+-100	24546	C4-1/8-TO-1003-F
A13R25	0757-0465	6		RESISTOR 100K 1% .125W F TC=0+-100	24546	C4-1/8-TO-1003-F
A13R26	2100-3163	8		RESISTOR-TRMR 1M 20% C SIDE-ADJ 17-TRN	02111	43P105
A13R27	0757-0444	1		RESISTOR 12.1K 1% .125W F TC=0+-100	24546	C4-1/8-TO-1212-F
A13R28	0757-0290	5		RESISTOR 6.19K 1% .125W F TC=0+-100	19701	MF4C1/8-TO-6191-F
A13R29	0757-1094	9		RESISTOR 1.47K 1% .125W F TC=0+-100	24546	C4-1/8-TO-1471-F
A13R30	0757-0402	1		RESISTOR 110 1% .125W F TC=0+-100	24546	C4-1/8-TO-111-F
A13R31	2100-3052	4		RESISTOR-TRMR 50 10% C SIDE-ADJ 17-TRN	02111	4AF500
A13R32				NOT ASSIGNED		
A13R33	0757-0442	9		RESISTOR 10K 1% .125W F TC=0+-100	24546	C4-11-TO-1002-F
A13R34	0757-0199	3		RESISTOR 21.5K 1% .125W F TC=0+-100	24546	C4-1/8-TO-2152-F
A13R35	0757-0288	1		RESISTOR 9.09K 1% .125W F TC=0+-100	19701	MF4C1/8-TO-9091-F
A13R36	0698-0083	8		RESISTOR 1.96K 1% .125W F TC=0+-100	24546	C4-1/8-TO-1961-F
A13R37	0757-0416	7		RESISTOR 511 1% .125W F TC=0+-100	24546	C4-1/8-TO-511R-F
A13R38	0698-3441	8		RESISTOR 215 1% .125W F TC=0+-100	24546	C4-1/8-TO-215R-F
A13R39	0757-0419	0		RESISTOR 681 1% .125W F TC=0+-100	24546	C4-1/8-TO-681R-F
A13R40	0698-3442	9		RESISTOR 237 1% .125W F TC=0+-100	24546	C4-1/8-TO-237R-F
A13R41	0757-0279	0		RESISTOR 3.16K 1% .125W F TC=0+-100	24546	C4-1/8-TO-3161-F
A13R42	0757-0442	9		RESISTOR 10K 1% .125W F TC=0+-100	24546	C4-1/8-TO-1002-F
A13043*	0757-0438	3	4	RESISTOR 5.11K 1% .125W F TC=0+-100	24546	C4-1/8-TO-5111-F
A13R44	0757-0442	9		RESISTOR 10K 1% .125W F TC=0+-100	24546	C4-1/8-TO-1002-F
A13R45	0757-0401	0		RESISTOR 100 1% .125W F TC=0+-100	24546	C4-1/8-TO-101 F

See introduction to this section for ordering information

*Indicates factory selected value

Table 6-3. Replaceable Parts

Reference Designation	HP Part Number	C D	Qty	Description	Mfr. Code	Mfr Part Number
A13R46	0757-0401	0		RESISTOR 100 1% .125W F TC=0+-100	24546	C4-1/8-TO-101-F
A13R47	0757-0346	2		RESISTOR 10 1% .125W F TC=0+-100	24546	C4-1/8-TO-10R0-F
A13R48*	0698-3156	2		RESISTOR 14.7K 1% .125W F TC=0+-100	24546	C4-1/8-TO-1472-F
A13R49	0757-0444	1		RESISTOR 12.1K 1% .125W F TC=0+-100	24546	C4-1/8-TO-1212-F
A13R50				NOT ASSIGNED		
A13R51	0757-0346	2		RESISTOR 10 1% .125W F TC=0+-100	24546	C4-1/8-TO-10R0-F
A13R52	0757-0290	5		RESISTOR 6.19K 1% .125W F TC=0+-100	19701	MF4C1/8-TO-6191-F
A13R53	0698-3440	7		RESISTOR 196 1% .125W F TC=0+-100	24546	C4-1/8-TO-196R-F
A13R54	0757-0416	7		RESISTOR 511 1% .125W F TC=0+-100	24546	C4-1/8-TO-511R-F
A13R55	0757-0442	9		RESISTOR 10K 1% .125W F TC=0+-100	24546	C4-1/8-TO-1002-F
A13R56*	0757-0274	5		RESISTOR 1.21K 1% .125W F TC=0+-100	24546	C4-1/8-TO-1211-F
A13R57	0757-0180	2		RESISTOR 31.6 1% .125W F TC=+-100	24546	0757-0180
A13R58	0698-3153	9		RESISTOR 3.83K 1% .125W F TC=0+-100	24546	C4-1/8-TO-3831-F
A13R59	0757-0180	2		RESISTOR 31.6 1% .125W F TC=0+-100	28480	0757-0180
A13R60	0698-3153	9		RESISTOR 3.83K 1% X .125W F TC=0+-100	24546	C4-1/8-TO-3831-F
A13TP1	0360-1788	7		CONNECTOR-SGL CONT PIN .045-IN-BSC-SZ SQ	28480	0360-1788
A13TP2	0360-1788	7		CONNECTOR-SGL CONT PIN .045-IN-BSC-SZ SQ	28480	0360-1788
A13TP3	1251-0600	0		CONNECTOR-SGL CONT PIN 1.14-MM-BSC-SZ SQ	28480	1251-0600
A13TP4	0360-1788	7		CONNECTOR-SGL CONT PIN .045-IN-BSC-SZ SQ	28480	0360-1788
A13TP5	0360-1788	7		CONNECTOR-SGL CONT PIN .045-IN-BSC-SZ SQ	28480	0360-1788
A13TP6	1251-0600	0		CONNECTOR-SGL CONT PIN 1.14-MM-BSC-SZ SQ	28480	1251-0600
A13TP7				NOT ASSIGNED		
A13TP8	1251-0600	0		CONNECTOR-SGL CONT PIN 1.14-MM-BSC-SZ SQ	28480	1251-0600
A13TP9	1251-0600	0		CONNECTOR-SGL CONT PIN 1.14-MM-BSC-SZ SQ	28480	1251-0600
A13TP10	1251-0600	0		CONNECTOR-SGL CONT PIN 1.14-MM-BSC-SZ SQ	28480	1251-0600
A13TP11	1251-0600	0		CONNECTOR-SGL CONT PIN 1.14-MM-BSC-SZ SQ	28480	1251-0600
A13VR1	1902-0048	1		DIODE-ZNR 6.81V 5% X DO-35 PD=.4W	28480	1902-0048
A13Y1/2	0410-0450	5		CRYSTAL, 21.4 MHZ (MATCHED SET OF 4; INCL. A13Y1, A13Y2, A11Y1 AND A11Y2)	28480	0410-0450
A14	5061-5411	2	1	LOG AMPLIFIER ASSEMBLY	28480	5061-5411
A14C1	0160-4554	7	65	CAPACITOR-FXD .01UF +-20% 50VDC CER	28480	0160-4554
A14C2	0180-0197	8		CAPACITOR-FXD 2.2UF +-10% 20VDC TA	56289	150D225X9020A2
A14C3	0160-4554	7		CAPACITOR-FXD .01UF +-20% 50VDC CER	28480	0160-4554
A14C4	0160-4554	7		CAPACITOR-FXD .1UF +-20% 50VDC CER	28480	0160-4554
A14C5	0160-4554	7		CAPACITOR-FXD .1UF +-20% 50VDC CER	28480	0160-4554
A14C6	0160-4554	7		CAPACITOR-FXD .01UF +-20% 50VDC CER	28480	0160-4554
A14C7	0160-3879	7		CAPACITOR-FXD .01UF +-20% 100VDC CER	28480	0160-3879
A14C8	0160-4554	7		CAPACITOR-FXD .01UF +-20% 50VDC CER	28480	0160-4554
A14C9	0160-4554	7		CAPACITOR-FXD .01UF +-20% 50VDC CER	28480	0160-4554
A14C10	0160-4554	7		CAPACITOR-FXD .01UF +-20% 50VDC CER	28480	0160-4554
A14C11	0160-4554	7		CAPACITOR-FXD .01UF +-20% 50VDC CER	28480	0160-4554
A14C12	0160-4554	7		CAPACITOR-FXD .01UF +-20% 50VDC CER	28480	0160-4554
A14C13				NOT ASSIGNED		
A14C14 THRU						
A14C34	0160-4554	7		CAPACITOR-FXD .01UF +-20% 50VDC CER	28480	0160-4554
A14C35				NOT ASSIGNED		
A14C36 THRU						
A14C69	0160-4554	7		CAPACITOR-FXD .01UF +-20% 50VDC CER	28480	0160-4554
A14C70	0160-4519	4	1	CAPACITOR-FXD 9.1PF +- .5PF 200VDC CER	28480	0160-4519
A14C71	0140-0195	2		CAPACITOR-FXD 130PF +-5% 300VDC MICA	72136	DM15F131J0300WV1CR
A14C72	0160-4386	3	1	CAPACITOR-FXD 33PF +-5% 200VDC CER 0+-30	28480	0160-4386
A14C73	0160-3872	0	1	CAPACITOR-FXD 2.2PF +- .25PF 200VDC CER	28480	0160-3872
A14C74	0160-4554	7		CAPACITOR-FXD .01UF +-20% 50VDC CER	28480	0160-4554
A14C75	0160-4554	7		CAPACITOR-FXD .01UF +-20% 50VDC CER	28480	0160-4554
A14C76	0160-4554	7		CAPACITOR-FXD .01UF +-20% 50VDC CER	28480	0160-4554
A14C77	0160-4554	7		CAPACITOR-FXD .01UF +-20% 50VDC CER	28480	0160-4554
A14CR1	1910-0016	0	1	DIODE-GE 60V 60MA 1US DO-7	28480	1910-0016
A14CR2	1901-0050	3		DIODE-SWITCHING 80V 200MA 2NS DO-35	28480	1901-0050
A14CR3				NOT ASSIGNED		
A14CR4	1901-0050	3		DIODE-SWITCHING 80V 200MA 2NS DO-35	28480	1901-0050
A14CR5				NOT ASSIGNED		
A14CR6	1901-1085	6	16	DIODE-SM SIG SCHOTTKY	28480	1901-1085
A14CR7	1901-1085	6		DIODE-SM SIG SCHOTTKY	28480	1901-1085
A14CR8	1901-1085	6		DIODE-SM SIG SCHOTTKY	28400	1901-1065
A14CR9	1901-1085	6		DIODE-SM SIG SCHOTTKY	28480	1901-1085
A14CR10	1901-1085	6		DIODE-SM SIG SCHOTTKY	28480	1901-1085
A14CR11	1901-1085	6		DIODE-SM SIG SCHOTTKY	28480	1901-1085
A14CR12	1901-1070	9		DIODE-PIN 110V	28480	1901-1070
A14CR13	1901-1085	6		DIODE-SM SIG SCHOTTKY	28480	1901-1085
A14CR14	1901-1085	6	1	DIODE-SM SIG SCHOTTKY	28480	1901-1085
A14CR15	1901-1070	9		DIODE-PIN 110V	28480	1901-1070

See introduction to this section for ordering information

*Indicates factory selected value

Table 6-3. Replaceable Parts

Reference Designation	HP Part Number	C D	Qty	Description	Mfr. Code	Mfr Part Number
A14CR16	1901-1070	9		DIODE-PIN 110V	28480	1901-1070
A14CR17	1901-1085	6		DIODE-SM SIG SCHOTTKY	28480	1901-1005
A14CR18	1901-1085	6		DIODE-SM SIG SCHOTTKY	28480	1901-1085
A14CR19	1901-1070	9		DIODE-PIN 110V	28480	1901-1070
A14CR20	1901-1085	6		DIODE-SM SIG SCHOTTKY	28480	1901-1085
A14CR21	1901-1085	6		DIODE-SM SIG SCHOTTKY	28400	1901-1085
A14CR22	1901-0040	1		DIODE-SWITCHING 30V 50MA 2NS DO-35	28480	1901-0040
A14CR23	1901-1085	6		DIODE-SM SIG SCHOTTKY	28480	1901-1005
A14CR24	1901-1005	6		DIODE-SM SIG SCHOTTKY	28480	1901-1085
A14CR25	1901-1070	9		DIODE-PIN 110V	28480	1901-1070
A14CR26	1901-1085	6		DIODE-SM SIG SCHOTTKY	28480	1901-1085
A14CR27	1901-1085	6		DIODE-SM SIG SCHOTTKY	28480	1901-1085
A14CR28	1901-1070	9		DIODE-PIN 110V	28480	1901-1070
A14CR29	1901-1070	9		DIODE-PIN 110V	28400	1901-1070
A14CR30	1901-1005	6		DIODE-SM SIG SCHOTTKY	28480	1901-1085
A14CR31	1901-0050	3		DIODE-SWITCHING 80V 200MA 2NS DO-35	28480	1901-0050
A14CR32	1901-0050	3		DIODE-SWITCHING 80V 200MA 2NS DO-35	28480	1901-0050
A14CR33	1901-0050	3		DIODE-SWITCHING 80V 200MA 2NS DO-35	28480	1901-0050
A14E1	9170-0029	3		CORE-SHIELDING BEAD	28480	9170-0029
A14L1	9100-1618	1	2	INDUCTOR RF-CH-MLD 5.6UH 10%	28480	9100-1618
A14L2	9140-0144	0		INDUCTOR RF-CH-MLD 4.7UH 10% .105DX.26LG	28480	9140-0144
A14L3	9140-0105	3	2	INDUCTOR RF-CH-MLD 8.2UH 10%	28480	9140-0105
A14L4	9100-1619	2	2	INDUCTOR RF-CH-MLD 6.8UH 10%	28480	9100-1619
A14L5	9100-1619	2		INDUCTOR RF-CH-MLD 6.8UH 10%	28480	9100-1619
A14L6	9140-0114	4		INDUCTOR RF-CH-MLD 10UH 10% .166DX.385LG	28480	9140-0114
A14L7	9140-0114	4		INDUCTOR RF-CH-MLD 10UH 10% .166DX.385LG	28480	9140-0114
A14L8	9140-0114	4		INDUCTOR RF-CH-MLD 10UH 10% .166DX.385LG	28480	9140-0114
A14L9	9140-0112	2		INDUCTOR RF-CH-MLD 4.7UH 10%	28480	9140-0112
A14L10	9140-0105	3		INDUCTOR RF-CH-MLD 8.2UH 10%	28480	9140-0105
A14L11	9100-1627	2	1	INDUCTOR RF-CH-MLD 39UH 5% .166DX.385LG	28480	9100-1627
A14L12	9100-1629	4	1	INDUCTOR RF-CH-MLD 47UH 5% .166DX.385LG	28480	9100-1629
A14L13	9100-1622	7	1	INDUCTOR RF-CH-MLD 24UH 5% .166DX.385LG	28480	9100-1622
A14L14	9100-2257	6	1	INDUCTOR RF-CH-MLD 820NH 10%X .105DX.26LG	28480	9100-2257
A14Q1	1854-0637	1	1	TRANSISTOR NPN 2N2219A SI TO-5 PD=800MW	01295	2N2219A
A14Q2	1853-0281	9	3	TRANSISTOR PNP 2N2907A SI TO-18 PD=400MW	04713	2N2907A
A14Q3	1853-0281	9		TRANSISTOR PNP 2N2907A SI TO-18 PD=400MW	04713	2N2907A
A14Q4	1053-0015	7	4	TRANSISTOR PNP SI PD=200MW FT=500MHZ	28480	1853-0015
A14Q5	1053-0015	7		TRANSISTOR PNP SI PD=200MW FT=500MHZ	28480	1853-0015
A14Q6	1853-0007	7		TRANSISTOR PNP 2N3251 SI TO-18 PD=360MW	04713	2N3251
A14Q7	1854-0019	3		TRANSISTOR NPN SI TO-18 PD=360MW	28480	1854-0019
A14Q8	1853-0015	7		TRANSISTOR PNP SI PD=200MW FT=500MHZ	28480	1853-0015
A14Q9	1854-0019	1		TRANSISTOR NPN SI TO-18 PD=360MW	28480	1854-0019
A14Q10	1853-0015	7	1	TRANSISTOR PNP SI PD=200MW FT=500MHZ	28480	1853-0015
A14Q11	1854-0019	3		TRANSISTOR NPN SI TO-18 PD=360MW	28480	1854-0019
A14Q12	1053-0015	7		TRANSISTOR PNP SI PD=200MW FT=500MHZ	28480	1853-0015
A14Q13	1854-0019	3		TRANSISTOR NPN SI TO-18 PD=360MW	28480	1854-0019
A14Q14	1854-0019	3		TRANSISTOR NPN SI TO-18 PD=360MW	28480	1854-0019
A14Q15	1854-0019	3		TRANSISTOR NPN SI TO-18 PD=360MW	28480	1854-0019
A14Q16	1854-0019	3		TRANSISTOR NPN SI TO-18 PD=360MW	28480	1854-0019
A14Q17	1854-0019	3		TRANSISTOR NPN SI TO-18 PD=360MW	28480	1854-0019
A14Q18	1854-0019	3		TRANSISTOR NPN SI TO-18 PD=360MW	28480	1854-0019
A14Q19	1854-0019	3		TRANSISTOR NPN SI TO-18 PD=360MW	28480	1854-0019
A14Q20	1854-0019	3		TRANSISTOR NPN SI TO-18 PD=360MW	28480	1854-0019
A14Q21	1854-0475	5		TRANSISTOR-DUAL NPN PD=750MW	28480	1854-0475
A14Q22	1854-0404	0		TRANSISTOR NPN SI TO -18 PD=360MW	28480	1854-0404
A14Q23	1853-0181	9		TRANSISTOR PNP 2N2907A SI TO-18 PD=400MW	04713	2N2907A
A14Q24	1854-0404	0		TRANSISTOR NPN SI TO-18 PD=360MW	28480	1854-0404
A14Q25	1854-0019	3		TRANSISTOR NPN SI TO-18 PD=360MW	28480	1854-0019
A14R1	0757-0117	7		RESISTOR 1.33K 1% .125W F TC=0+-100	24546	C4-1/8-TO-1331-F
A14R2	0757-0280	3		RESISTOR 1K 1% .125W F TC=0+-100	24546	C4-1/8-TO-1001-F
A14R3	0698-0084	9	2	RESISTOR 2.15K 1% .125W F TC=0+-100	24546	C4-1/8-TO-2151-F
A14R4	0698-1430	5	1	RESISTOR 21.5 1% .125W F TC=0+-100	03888	PME55-1/8-TO-21R5-F
A14R5	0757-0443	0	1	RESISTOR 11K 1% .125W F TC=0+-100	24546	C4-1/8-TO-1102-F
A14R6	0757-0442	9		RESISTOR 10K 1% .125W F TC=0+-100	24546	C4-1/8-TO-1002-F
A14R7	0757-0465	6		RESISTOR 100K 1% .125W F TC=0+-100	24546	C4-1/8-TO-1003--F
A14R8	0757-0442	9		RESISTOR 10K 1% .125W F TC=0+-100	24546	C4-1/8-TO-1002-F
A14R9	0698-3450	9		RESISTOR 42.2K 1% .125W F TC=0+-100	24546	C4-1/8-TO-4222-F
A14R10	2100-2633	5	2	RESISTOR-TRMR 1K 10% C SIDE-ADJ 1-TRN	30983	ET50X102
A14R11	0698-3155	1	4	RESISTOR 4.64K 1% .125W F TC=0+-100	24546	C4-1/8-TO-4641-F
A14R12	0757-0458	7		RESISTOR 51.1K 1% .125W F TC=0+-100	24546	C4-1/8-TO-5112-F
A14R13	0757-0401	0		RESISTOR 100 1% .125W F TC=0+-100	24546	C4-1/8-TO-101-F
A14R14	0757-0460	1		RESISTOR 61.9K 1% .125W F TC=0+-100	24546	C4-1/8-TO-6192-F
A14R15	0757-0458	7		RESISTOR 51.1K 1% .125W F TC=0+-100	24546	C4-1/8-TO-5112-F

See introduction to this section for ordering information

*Indicates factory selected value

Table 6-3. Replaceable Parts

Reference Designation	HP Part Number	C D	Qty	Description	Mfr. Code	Mfr Part Number
A14R16	0757-0180	2		RESISTOR 31.6 1% .125W F TC=0+-100	28480	0757-0180
A14R17	0757-0464	5		RESISTOR 90.9K 1% .125W F TC=0+-100	24546	C4-1/8-TO-9092-F
A14R18	0698-3136	8		RESISTOR 17.8K 1% .125W F TC=0+-100	24546	C4-1/8-TO-1782-F
A14R19	0757-0123	3	1	RESISTOR 34.8K 1% .125W F TC=0+-100	28480	0757-0123
A14R20	0698-0003	8		RESISTOR 1.96K 1% .125W F TC=0+-100	24546	C4-1/8-TO-1961-F
A14R21	2100-2489	9	2	RESISTOR-TRMR 5K 10% C SIDE-ADJ 1-TRN	30983	ET50X502
A14R22	0698-3452	1	1	RESISTOR 147K 1% .125W F TO=0+-100	24546	C4-1/8-TO-1473-F
A14R23	2100-2514	1	1	RESISTOR-TRMR 20K 10% C SIDE-ADJ 1-TRN	30983	ET50W203
A14R24	0757-0274	5		RESISTOR 1.21K 1% .125W F TC=0+-100	24546	C4-1/8-TO-1211-F
A14R25	0757-0274	5		RESISTOR 1.21K 1% .125W F TC=0+-100	24546	C4-1/8-TO-1211-F
A14R26	0757-0274	5		RESISTOR 1.21K 1% .125W F TC=0+-100	24546	C4-1/8-TO-1211-F
A14R27	2100-2489	9		RESISTOR-TRMR 5K 10% C SIDE-ADJ 1-TRN	30983	ET50X502
A14R28	0757-0346	2		RESISTOR 10 1% .125W F TC=0+-100	24546	C4-1/8-TO-10R0-F
A14R29	0757-0346	2		RESISTOR 10 1% .125W F TC=0+-100	24546	C4-1/8-TO-10R0-F
A14R30	2100-2522	1		RESISTOR-TRMR 10K 10% C SIDE-ADJ 1-TRN	30983	ET50X103
A14R31	0757-0346	2		RESISTOR 10 1% .125W F TC=0+-100	24546	C4-1/8-TO-10R0-F
A14R32	0757-0346	2		RESISTOR 10 1% .125W F TC=0+-100	24546	C4-1/8-TO-10R0-F
A14R33	2100-2522	1		RESISTOR-TRMR 10K 10% C SIDE-ADJ 1-TRN	30983	ET50X103
A14R34	2100-2521	0	1	RESISTOR-TRMR 2K 10% C SIDE-ADJ 1-TRN	30983	ET50X202
A14R35	0757-0346	2		RESISTOR 10 1% .125W F TC=0+-100	24546	C4-1/8-TO-10R0-F
A14R36	0757-0346	2		RESISTOR 10 1% .125W F TC=0+-100	24546	C4-1/8-TO-10R0-F
A14R37	0757-0442	9		RESISTOR 10K 1% .125W F TC=0+-100	24546	C4-1/8-TO-1002-F
A14R38	0698-3151	7		RESISTOR 2.87K 1% .125W F TC=0+-100	24546	C4-1/8-TO-2871-F
A14R39	2100-2520	9	1	RESISTOR-TRMR 50 20% C SIDE-ADJ 1-TRN	30983	ET50X500
A14R40	0757-0442	9		RESISTOR 10K 1% .125W F TC=0+-100	24546	C4-1/8-TO-1002-F
A14R41	0757-0290	5		RESISTOR 6.19K 1% .125W F TC=0+-100	19701	MF4C1/8-TO-6191-F
A14R42	0757-0200	7		RESISTOR 5.62K 1% .125W F TC=0+-100	24546	C4-1/8-TO-5621-F
A14R43	0757-0447	4		RESISTOR 16.2K 1% .125W F TC=0+-100	24546	C4-1/8-TO-1622-F
A14R44	0757-0420	3		RESISTOR 750 1% .125W F TC=0+-100	24546	C4-1/8-TO-751-F
A14R45	0698-3444	1		RESISTOR 316 1% .125W F TC=0+-100	24546	C4-1/8-TO-316R-F
A14R46	0698-3156	2		RESISTOR 14.7K 1% .125W F TC=0+-100	24546	C4-1/8-TO-1472-F
A14R47	0757-0346	2		RESISTOR 10 1% .125W F TC=0+-100	24546	C4-1/8-TO-10R0-F
A14R48	0698-3150	6		RESISTOR 2.371K 1% .125W F TC=0+-100	24546	C4-1/8-TO-2371-F
A14R49	0698-3132	4		RESISTOR 261 1% .125W F TC=0+-100	24546	C4-1/8-TO-2610-F
A14R50	0757-0279	0		RESISTOR 3.16K 1% .125W F TC=0+-100	24546	C4-1/8-TO-3161-F
A14R51	0757-0346	2		RESISTOR 10 1% .125W F TC=0+-100	24546	C4-1/8-TO-10R0-F
A14R52	0698-3444	1		RESISTOR 316 1% .125W F TC=0+-100	24546	C4-1/8-TO-316R-F
A14R53	0757-0444	1		RESISTOR 12.1K 1% .125W F TC=0+-100	24546	C4-1/8-TO-1212-F
A14R54	0757-0444	1		RESISTOR 12.1K 1% .125W F TC=0+-100	24546	C4-1/8-TO-1212-F
A14R55	0757-0440	7		RESISTOR 7.5K 1% .125W F TC=0+-100	24546	C4-1/8-TO-7501-F
A14R56	0757-0401	0		RESISTOR 100 1% .125W F TC=0+-100	24546	C4-1/8-TO-101-F
A14R57	0757-0280	3		RESISTOR 1K 1% .125W F TC=0+-100	24546	C4-1/8-TO-1001-F
A14R58	0757-0346	2		RESISTOR 10 1% .125W F TC=0+-100	24546	C4-1/8-TO-10R0-F
A14R59	0698-3150	6		RESISTOR 2.37K 1% .125W F TC=0+-100	24546	C4-1/8-TO-2371-F
A14R60	0698-3444	1		RESISTOR 316 1% .125W F TC=0+-100	24546	C4-1/8-TO-316R-F
A14R61	0757-0200	3		RESISTOR 1K 1% .125W F TC=0+-100	24546	C4-1/8-TO-1001-F
A14R62	0757-0444	1		RESISTOR 12.1K 1% .125W F TC=0+-100	24546	C4-1/8-TO-1212-F
A14R63	0757-0444	1		RESISTOR 12.1K 1% .125W F TC=0+-100	24546	C4-1/8-TO-1212-F
A14R64	0757-0440	7		RESISTOR 7.5K 1% .125W F TC=0+-100	24546	C4-1/8-TO-7501-F
A14R65	0757-0401	0		RESISTOR 100 1% .125W F TC=0+-100	24546	C4-1/8-TO-101-F
A14R66	0757-0280	3		RESISTOR 1K 1% .125W F TC=0+-100	24546	C4-1/8-TO-1001-F
A14R67	0757-0346	2		RESISTOR 10 1% .125W F TC=0+-100	24546	C4-1/8-TO-10R0-F
A14R68	0698-8958	2	1	RESISTOR 511K 1% .125W F TC=0+-100	28480	0698-0958
A14R69	2100-2692	6	1	RESISTOR-TRMR 1M 20% C SIDE-ADJ 1-TRN	30983	ET5X105
A14R70	0698-3444	1		RESISTOR 316 1% .125W F TC=0+-100	24546	C4-1/8-TO-316R-F
A14R71	0757-0279	0		RESISTOR 3.16K 1% .125W F TC=0+-100	24546	C4-1/8-TO-3161-F
A14R72	0707-0444	1		RESISTOR 12.1K 1% .125W F TC=0+-100	24546	C4-1/8-TO-1212-F
A14R73	0757-0444	1		RESISTOR 12.1K 1% .125W F TC=0+-100	24546	C4-1/8-TO-1212-F
A14R74	0757-0440	7		RESISTOR 7.5K 1% .125W F TC=0+-100	24546	C4-1/8-TO-7501-F
A14R75	0757-0401	0		RESISTOR 100 1% .125W F TC=0+-100	24546	C4-1/8-TO-101-F
A14R76	0757-0280	3		RESISTOR 1K 1% .125W F TC=0+-100	24546	C4-1/8-TO-101-F
A14R77	0757-0346	2		RESISTOR 10 1% .125W F TC=0+-100	24546	C4-1/8-TO-10R0-F
A14R78	0698-3150	6		RESISTOR 2.37K 1% .125W F TC=0+-100	24546	C4-1/8-TO-2371-F
A14R79	0690-3444	1		RESISTOR 316 1% .125W F TC=0+-100	24546	C4-1/8-TO-316R-F
A14R80	0757-0289	2		RESISTOR 13.3K 1% .125W F TC=0+-100	19701	MF4C1/8-TO-1332-F
A14R81	0757-0289	2		RESISTOR 13.3K 1% .125W F TC=0+-100	19701	MF4C1/8-TO-1332-F
A14R82	0757-0440	7		RESISTOR 7.5K 1% .125W F TC=0+-100	24546	C4-1/8-TO-7501-F
A14R83	0757-0401	0		RESISTOR 100 1% .125W F TC=0+-100	24546	C4-1/8-TO-101-F
A14R84	0757-0280	3		RESISTOR 1K 1% .125W F TC=0+-100	24546	C4-1/8-TO-1001-F
A14R85	0757-0279	0		RESISTOR 3.16K 1% .125W F TC=0+-100	24546	C4-1/8-TO-3161-F
A14R86	0757-0346	2		RESISTOR 10 1% .125W F TC=0+-100	24546	C4-1/8-TO-10R0-F
A14R87	0698-3444	1		RESISTOR 316 1% .125W F TC=0+-100	24546	C4-1/8-TO-316R-F
A14R88	2100-2522	1		RESISTOR-TRMR 10K 10% C SIDE-ADJ 1-TRN	30983	ET50X103
A14R89	0757-0440	7		RESISTOR 7.5K 1% .125W F TC=0+-100	24546	C4-1/8-TO-7501-F
A14R90	0757-0403	2	2	RESISTOR 121 1% .125W F TC=0+-100	24546	C4-1/8-TO-121R-F

See introduction to this section for ordering information

*Indicates factory selected value

Table 6-3. Replaceable Parts

Reference Designation	HP Part Number	C D	Qty	Description	Mfr. Code	Mfr Part Number
A14R91	0757-0289	2		RESISTOR 13.3K 1% .125W F TC=0+-100	19701	MF4C1/8-TO-1332-F
A14R92	0757-0289	2		RESISTOR 13.3K 1% .125W F TC=0+-100	19701	MF4C1/8-TO-1332-F
A14R93*	0698-3153	9		RESISTOR 3.83K 1% .125W F TC=0+-100	24546	C4-1/8-TO-3831-F
A14R94	0698-3150	6		RESISTOR 2.37K 1% .125W F TC=0+-100	24546	C4-1/8-TO-2371-F
A14R95	0757-0346	2		RESISTOR 10 1% .125W F TC=0+-100	24546	C4-1/8-TO-10R0-F
A14R96	0698-3444	1		RESISTOR 316 1% .125W F TC=0+-100	24546	C4-1/8-TO-316R-F
A14R97	0757-0289	2		RESISTOR 13.3K 1% .125W F TC=0+-100	19701	MF4C1/8-TO-1332-F
A14R98	0757-0289	2		RESISTOR 13.3K 1% .125W F TC=0+-100	19701	MF4C1/8-TO-1332-F
A14R99	0757-0440	7		RESISTOR 7.5K 1% .125W F TC=0+-100	24546	C4-1/8-TO-7501-F
A14R100	0757-0403	2		RESISTOR 121 1% .125W F TC=0+-100	24546	C4-1/8-TO-121R-F
A14R101*	0698-3153	9		RESISTOR 3.83K 1% .125W F TC=0+-100	24546	C4-1/8-TO-3831-F
A14R102	0757-0346	2		RESISTOR 10 1% .125W F TC=0+-100	24546	C4-1/8-TO-10R0-F
A14R103	0757-0401	0		RESISTOR 100 1% .125W F TC=0+-100	24546	C4-1/8-TO-101-F
A14R104	0757-0401	0		RESISTOR 100 1% .125W F TC=0+-100	24546	C4-1/8-TO-101-F
A14R105	0698-3444	1		RESISTOR 316 1% .125W F TC=0+-100	24546	C4-1/8-TO-316R-F
A14R106	0757-0417	8		RESISTOR 562 1% .125W F TC=0+-100	24546	C4-1/8-TO-562R-F
A14R107*	0757-0199	3	33	RESISTOR 21.5K 1% .125W F TC=0+-100	24546	C4-1/8-TO-2152-F
A14R108	0698-3434	9	1	RESISTOR 34.8 1% .125W F TC=0+-100	24546	C4-1/8-TO-34R8-F
A14R109	0757-0400	9		RESISTOR 90.9 1% .125W F TC=0+-100	24546	C4-1/8-TO-90R9-F
A14R110	0757-0418	9		RESISTOR 619 1% .125W F TC=0+-100	24546	C4-1/8-TO-619R-F
A14R111	0698-3440	7		RESISTOR 196 1% .125W F TC=0+-100	24546	C4-1/8-TO-196R-F
A14R112	0757-0280	3		RESISTOR 1K 1% .125W F TC=0+-100	24546	C4-1/8-TO-1001-F
A14R113	0757-0280	3		RESISTOR 1K 1% .125W F TC=0+-100	24546	C4-1/8-TO-1001-F
A14R114	0698-3136	8		RESISTOR 17.8K 1% .125W F TC=0+-100	24546	C4-1/8-TO-1782-F
A14R115	0757-0401	0		RESISTOR 100 1% .125W F TC=0+-100	24546	C4-1/8-TO-101-F
A14R116	0757-0418	9		RESISTOR 619 1% .125W F TC=0+-100	24546	C4-1/8-TO-619R-F
A14R117	0757-0440	7		RESISTOR 7.5K 1% .125W F TC=0+-100	24546	C4-1/8-TO-7501-F
A14R118	0698-0085	0		RESISTOR 2.61K 1% .125W F TC=0+-100	24546	C4-1/8-TO-2611-F
A14R119	0698-3438	3		RESISTOR 147 1% .125W F TC=0+-100	24546	C4-1/8-TO-147R-F
A14R120	0757-0439	4		RESISTOR 6.81K 1% .125W F TC=0+-100	24546	C4-1/8-TO-6811-F
A14R121	2100-2633	5		RESISTOR-TRMR 1K 10% C SIDE-ADJ 1-TRN	30983	ET50X102
A14R122	0757-0420	3		RESISTOR 750 1% .125W F TC=0+-100	24546	C4-1/8-TO-751-F
A14R123	0757-0440	7		RESISTOR 7.5K 1% .125W F TC=0+-100	24546	C4-1/8-TO-7501-F
A14R124	0757-0447	4		RESISTOR 16.2K 1% .125W F TC=0+-100	24546	C4-1/8-TO-1622-F
A14R125	0757-0447	4		RESISTOR 16.2K 1% .125W F TC=0+-100	24546	C4-1/8-TO-1622-F
A14R126	0757-0465	6		RESISTOR 100K 1% .125W F TC=0+-100	24546	C4-1/8-TO-1003-F
A14R127	0757-0465	6		RESISTOR 100K 1% .125W F TC=0+-100	24546	C4-1/8-TO-1003-F
A14R128	0757-0465	6		RESISTOR 100K 1% .125W F TC=0+-100	24546	C4-1/8-TO-1003-F
A14R129	0698-0083	8		RESISTOR 1.96K 1% .125W F TC=0+-100	24546	C4-1/8-TO-1961-F
A14R130	0757-0279	0		RESISTOR 3.16K 1% .125W F TC=0+-100	24546	C4-1/8-TO-3161-F
A14R131	0757-0402	1		RESISTOR 110 1% .125W F TC=0+-100	24546	C4-1/8-TO-111-F
A14R132	0757-1438	5	1	RESISTOR-5.11K 1% .125W F TC=0+-100	28480	0757-1438
A14R133	0698-7212	9		RESISTOR 100 1% .05W F TC=0+-100	24546	C3-1/8-TO-101R-F
A14R134	0698-7212	9		RESISTOR 100 1% .05W F TC=0+-100	24546	C3-1/8-TO-100R-F
A14TP1	0360-0535	0		TERMINAL TEST POINT PCB	00000	ORDER BY DESCRIPTION
A14TP2	0360-0535	0		TERMINAL TEST POINT PCB	00000	ORDER BY DESCRIPTION
A14TP3	0360-0535	0		TERMINAL TEST POINT PCB	00000	ORDER BY DESCRIPTION
A14TP4	0360-0535	0		TERMINAL TEST POINT PCB	00000	ORDER BY DESCRIPTION
A14TP5	0360-0535	0		TERMINAL TEST POINT PCB	00000	ORDER BY DESCRIPTION
A14TP6	0360-0535	0		TERMINAL TEST POINT PCB	00000	ORDER BY DESCRIPTION
A14TP7	0360-0535	0		TERMINAL TEST POINT PCB	00000	ORDER BY DESCRIPTION
A14TP8	0360-0535	0		TERMINAL TEST POINT PCB	00000	ORDER BY DESCRIPTION
A14TP9	0360-0535	0		TERMINAL TEST POINT PCB	00000	ORDER BY DESCRIPTION
A14TP10	0360-0535	0		TERMINAL TEST POINT PCB	00000	ORDER BY DESCRIPTION
A14U1	1826-0092	3		IC OP AMP GP DUAL TO-99 PKG	28480	1826-0092
A14U2	1826-0092	3		IC OP AMP GP DUAL TO-99 PKG	28480	1826-0092
A14VR1	1902-0901	5	1	DIODE-ZNR 5.4V 1% DO-35 PD=-.4W TC=+.046%	28480	1902-0901
A15	08558-60015	8	1	VERTICAL DRIVE AND BLANKING	28480	08558-00015
A15C1	0180-0197	8		CAPACITOR-FXD 2.2UF+-10% 20VDC TA	56289	150D225X9020A2
A15C2	0180-0197	8		CAPACITOR-FXD 2.2UF+-10% 20VDC TA	56289	150D225X9020A2
A15C3	0180-0197	8		CAPACITOR-FXD 2.2UF+-10% 20VDC TA	56289	150D225X9020A2
A15C4	0160-2055	9		CAPACITOR-FXD .01UF +80-20% 100VDC CER	28480	0160-2055
A15C5	0180-0197	8		CAPACITOR-FXD 2.2UF+-10% 20VDC TA	56289	150D225X9020A2
A15C6	0160-2055	9		CAPACITOR-FXD .01UF +80-20% 100VDC CER	28400	0160-2055
A15CR1	1901-0040	1		DIODE-SWITCHING 30V 50MA 2NS DO-35	28480	1901-0040
A15CR2	1901-0040	1		DIODE-SWITCHING 30V 50MA 2NS DO-35	28400	1901-0040
A15CR3	1901-0040	1		DIODE-SWITCHING 30V 50MA 2NS DO-35	28480	1901-0040
A15CR4	1901-0535	9		DIODE-SM SIG SCHOTTKY	28450	1901-0535
A15CR5	1901-0040	1		DIODE-SWITCHING 30V 50MA 2NS DO-35	28480	1901-0040
A15CR6	1901-0040	1		DIODE-SWITCHING 30V 50MA 2NS DO-35	28480	1901-0040
A15CR7	1901-0040	1		DIODE-SWITCHING 30V 50MA 2NS DO-35	28480	1901-0040
A15CR8	1901-0040	1		DIODE-SWITCHING 30V 50MA 2NS DO-35	28480	1901-0040
A15CR9	1901-0050	3		DIODE-SWITCHING 80V 200MA 2NS DO-35	28480	1901-0050
A15CR10	1901-0050	3		DIODE-SWITCHING 80V 200MA 2NS DO-35	28480	1901-0050

See introduction to this section for ordering information

*Indicates factory selected value

Table 6-3. Replaceable Parts

Reference Designation	HP Part Number	C D	Qty	Description	Mfr. Code	Mfr Part Number
A15CR11	1901-0050	3		DIODE-SWITCHING 80V 200MA 2NS DO-35	28480	1901-0050
A15CR12	1901-0518	8	1	DIODE-SM SIG SCHOTTKY	28480	1901-0518
A15L1	9140-0179	1		INDUCTOR RF-CH-MLD 22UH 10% .166DX.385LG	28480	9140-0179
A15L2	9140-0179	1		INDUCTOR RF-CH-MLD 22UH 10% .166DX.385LG	28480	9140-0179
A15MP1	1200-0173	5		INSULATOR-XSTR DAP-GL	28480	1200-0173
A15Q1	1853-0007	7		TRANSISTOR PNP 2N3251 SI TO-18 PD=360MW	04713	2N3251
A15Q2	1854-0234	4	4	TRANSISTOR NPN 2N3440 SI TO-5 PD=1W	3L585	2N3440
A19Q3	1854-0234	4		TRANSISTOR NPN 2N3440 SI TO-5 PD=1W	3L585	2N3440
A15Q4	1854-0009	1	1	TRANSISTOR NPN SI PD=300MW FT=600MHZ	04713	2N709
A15Q5	1854-0404	0		TRANSISTOR NPN SI TO-18 PD=360MW	28480	1854-0404
A15Q6	1854-0234	4		TRANSISTOR NPN 2N3440 SI TO-5 PD=1W	3L585	2N3440
A15Q7	1854-0234	4		TRANSISTOR NPN 2N3440 SI TO-5 PD=1W	3L585	2N3440
A15Q8	1853-8007	7		TRANSISTOR PNP 2N3251 SI TO-18 PD=360MW	04713	2N3251
A15Q9	1854-0019	3		TRANSISTOR NPN SI TO-18 PD=360MW	28480	1854-0019
A15Q10	1854-0039	7		TRANSISTOR NPN 2N3053S SI TO-39 PD=1W	3L585	2N3053S
A15Q11	1853-0451	5		TRANSISTOR PNP 2N3799 SI TO-18 PD=360MW	01295	2N3799
A15Q12	1853-0451	5		TRANSISTOR NPN 2N3799 SI TO-18 PD=360MW	01295	2N3799
A15Q13	1854-0404	0		TRANSISTOR NPN SI TO-18 PD=360MW	28480	1854-0404
A15Q14	1854-0475	5		TRANSISTOR-DUAL NPN PD=750MW	28480	1854-0475
A15Q15	1854-0404	0		TRANSISTOR NPN SI TO-18 PD=360MW	28480	1854-0404
A15Q16	1853-0007	7		TRANSISTOR PNP 2N3251 SI TO-18 PD=360MW	04713	2N3251
A15Q17	1855-0049	1	1	TRANSISTOR-JFET DUAL N-CHAN D-MODE SI	28480	1855-0049
A15Q18	1854-0404	0		TRANSISTOR NPN SI TO-18 PD=360MW	28480	1854-0404
A15Q19	1855-0417	7		TRANSISTOR J-FET N-CHAN D-MODE TO-18 SI	28480	1855--0417
A15Q20	1854-0404	0		TRANSISTOR NPN SI TO-18 PD=360MW	28480	1854-0404
A15Q21	1855-0020	8	1	TRANSISTOR J-FET N-CHAN D-MODE TO-18 SI	28480	1855-0020
A15R1	2100-3123	0		RESISTOR-TRMR 500 10% C SIDE-ADJ 17-TRN	02111	43P501
A15R2	0757-0199	3		RESISTOR 21.5K 1% .125W F TC=0+-100	24546	C4-1/8-TO-2152-F
A15R3	0757-0420	3		RESISTOR 750 1% .125W F TC=0+-100	24546	C4-1/8-TO-751-F
A15R4	0757-0280	3		RESISTOR 1K 1% .125W F TC=0+-100	24546	C4-1/8-TO-1001-F
A15R5	0757-0279	0		RESISTOR 3.16K 1% .125W F TC=0+-100	24546	C4-1/8-TO-3161-F
A15R6	0698-3156	2		RESISTOR 14.7K 1% .125W F TC=0+-100	24546	C4-1/8-TO-1472-F
A15R7	0757-0444	1		RESISTOR 12.1K 1% .125W F TC=0+-100	24546	C4-1/8-TO-1212-F
A15R8	0757-0424	7		RESISTOR 1.1K 1% .125W F TC=0+-100	24546	C4-1/8-TO-1101-F
A15R9	0698-3156	2		RESISTOR 14.7K 1% .125W F TC=0+-100	24546	C4-1/8-TO-1472-F
A15R10	8757-0199	3		RESISTOR 21.5K 1% .125W F TC=0+-100	24546	C4-1/8-TO-2152-F
A15R11	0698-3155	1		RESISTOR 4.64K 1% .125W F TC=0+-100	24546	C4-1/8-TO-4641-F
A15R12	0757-0416	7		RESISTOR 511 1% .125W F TC=0+-100	24546	C4-1/8-TO-511R-F
A15R13	0683-0475	1		RESISTOR 4.7 5% .25W FC TC=-400/+500	01121	CB47G5
A15R14	0757-0424	7		RESISTOR 1.1K 1% .125W F TC=0+-100	24546	C4-1/8-TO-1101-F
A15R15	0757-0199	3		RESISTOR 21.5K 1% .125W F TC=0+-100	24546	C4-1/8-TO-2152-F
A15R16	0757-0199	3		RESISTOR 21.5K 1% .125W F TC=0+-100	24546	C4-1/8-TO-2152-F
A15R17	0757-0280	3		RESISTOR 1K 1% .125W F TC=0+-100	24546	C4-1/8-TO-1001-F
A15R18	0698-3155	1		RESISTOR 4.64K 1% .125W F TC=0+-100	24546	C4-1/8-TO-4641-F
A15R19	0698-0084	9		RESISTOR 2.15K 1% .125W F TC=0+-100	24546	C4-1/8-TO-2151-F
A15R20	0757-0416	7		RESISTOR 511 1% .125W F TC=0+-100	24546	C4-1/8-TO-511R-F
A15R21	0683-1055	5		RESISTOR 1M 5% .25W FC TC=-800/+900	01121	CB1055
A15R22	0757-0442	9		RESISTOR 10K 1% .125W F TC=0+-100	24546	C4-1/8-TO-1002-F
A15R23	0757-0465	6		RESISTOR 100K 1% .125W F TC=0+-100	24546	C4-1/8-TO-1003-F
A15R24	0757-0442	9		RESISTOR 10K 1% .125W F TC=0+-100	24546	C4-1/8-TO-1002-F
A15R25	0757-0199	3		RESISTOR 21.5K 1% .125W F TC=0+-100	24546	C4-1/8-TO-2152-F
A15R26*	0698-3153	9		RESISTOR 3.83K 1% .125WF TC=0+-100	24546	C4-1/8-TO-3831-F
A15R27	0698-3440	7		RESISTOR 196 1% .125W F TC=0+-100	24546	C4-1/8-TO-196R-F
A15R28	0698-3440	7		RESISTOR 196 1% .125W F TC=0+-100	24546	C4-1/8-TO-196R-F
A15R29	0757-0279	0		RESISTOR 3.16K 1% .125W F TC=0+-100	24546	C4-1/8-TO-3161-F
A15R30	0698-3156	2		RESISTOR 14.7K 1% .125W F TC=0+-100	24546	C4-1/8-TO-1472-F
A15R31	0757-0444	1		RESISTOR 12.1K 1% .125W F TC=0+-100	24546	C4-1/8-TO-1212-F
A15R32	0698-3444	1		RESISTOR 316 1% .125W F TC=0+-100	24546	C4-1/8-TO-316R-F
A15R33	0757-0424	7		RESISTOR 1.1K 1% .125W F TC=0+-100	24546	C4-1/8-TO-1101-F
A15R34	0698-3156	2		RESISTOR 14.7K 1% .125W F TC=0+-100	24546	C4-1/8-TO-1472-F
A15R35	0757-0279	0		RESISTOR 3.16K 1% .125W F TC=0+-100	24546	C4-1/8-TO-3161-F
A15R36	0757-0200	7		RESISTOR 5.62K 1% .125W F T=0+-100	24546	C4-1/8-TO-5621-F
A15R37	0757-0465	6		RESISTOR 100K 1% .125W F TC=0+-100	24546	C4-1/8-TO-1013-F
A15R38	0757-0199	3		RESISTOR 21.5K 1% .125W F TC=0+-100	24546	C4-1/8-TO-2152-F
A15R39	0698-3444	1		RESISTOR 316 1% .125W F TC=0+-100	24546	C4-1/8-TO-316R-F
A15R40	0757-0394	0	1	RESISTOR 51.1 1% .125W F TC=0+-100	24546	C4-1/8-TO-51R1-F
A15R41	0698-3155	1		RESISTOR 4.64K 1% .125W F TC=0+-100	24546	C4-1/8-TO-4641-F
A15R42	0757-0416	7		RESISTOR 511 1% .125W F TC=0+-100	24546	C4-1/8-TO-511R-F
A15R43	0757-0442	9		RESISTOR 10K 1% .125W FTC=0+-100	24546	C4-1/8-TO-1002-F
A15R44	0698-3444	1		RESISTOR 316 1% .125W F TC=0+-100	24546	C4-1/8-TO-316R-F
A15R45	0757-0837	6	2	RESISTOR 8.25K 1% .5W F TC=0+-100	28480	0757-0837
A15R46	0757-0844	5	2	RESISTOR 16.2K 1% .5W F TC=0+-100	28480	0757-0844
A15R47	0698-3440	7		RESISTOR 196 1% .125W F TC=0+-100	24546	C4-1/8-TO-196R-F
A15R48	0757-0420	3		RESISTOR 750 1% .125W F TC=0+-100	24546	C4-1/8-TO-751-F
A15R49	0757-0844	5		RESISTOR 16.2K 1% .5W F TC=0+-100	28480	0757-0844
A15R50	0698-3440	7		RESISTOR 196 1% .125W F TC=0+-100	24546	C4-1/8-TO-196R-F

See introduction to this section for ordering information

*Indicates factory selected value

Table 6-3. Replaceable Parts

Reference Designation	HP Part Number	C D	Qty	Description	Mfr. Code	Mfr Part Number
A15R51	0757-0837	6		RESISTOR 8.25K 1% .5W F TC=0+-100	28480	0757-0837
A15R52	0698-3444	1		RESISTOR 316 1% .125W F TC=0+-100	24546	C4-1/8-TO-316R-F
A15R53	0698-3260	9		RESISTOR 464K 1% .125W F TC=0+-100	28480	0698-3260
A15R54	0698-3446	3		RESISTOR 383 1% .125W F TC=0+-100	24546	C4-1/8-TO-383R-F
A15R55	0757-0280	3		RESISTOR 1K 1% .125W F TC=0+-100	24546	C4-1/8-TO-1001-F
A15R56	0698-7284	5	1	RESISTOR 100K 1% .125W F TC=0+-100	24546	C3-1/8-TO-1003-F
A15V1	1826-0092	3		IC OF AMP GP DUAL TO-99 PKG	28480	11326-0092
A15V2	1E58-0032	8		TRANSISTOR ARRAY 14-PIN PLSTC DIP	3L585	CA3146E
A15VR1	1902-0033	4		DIODE-ZNR 1N823 6.2V 5% DO-7 PD=.4W	24046	1N823
A15VR2	1902-0202	9		DIODE-ZNR 15V 5% PD=1W 1R=5UA	28480	1902-0202
A15VR3	1902-0556	6	1	DIODE-ZNR 20V 5% PD=1W 1R=5UA	28480	1902-0556
A15TP1 THRU A15TP8	1251-0600	0		CONNECTOR-SGL CONT PIN 1.14-MM-BSC-SZ SQ	28480	1251-0600
A16	08558-65159	1	1	MOTHERBOARD (INCL W12, W13 & P1)	28480	08558-65159
A16C1	0160-3879	7		CAPACITOR-FXD .01UF +-20 100VDC CER	28480	0160-3879
A16C2	0160-3879	7		CAPACITOR-FXD .01UF +-20 100VDC CE.R	2B480	0160-3879
A16C3	0160-3879	7		CAPACITOR-FXD .01UF +-20 100VDC CER	28480	0160-3879
A16C4	0160-3879	7		CAPACITOR-FXD .01UF +-20 100VDC CER	28480	0160-3879
A16C5	0180-0197	8		CAPACITOR-FXD 2.2UF+-10% 20VDC TA	56289	150D225X9020A2
A16C6	0180-0197	8		CAPACITOR-FXD 2.2UF+-10% 20VDC TA	56289	150D225X9020A2
A16C7	0160-3879	7		CAPACITOR-FXD .01UF +-20% 100VDC CER	28480	0160-3879
A16C8 THRU A16C14	0160-2055			CAPACITOR-FXD .01UF +80-20% 100VDC CER	28480	0160-2055
A16CR1	1901-0033			DIODE-GEN PRP 180V 200MA DO-7	28480	1901-0033
A16CR2	1901-0376			DIODE-GEN PRP 35V 50MA DO-35	28480	1901-0376
A16CR3	1901-0050			DIODE-SWITCHING 80V 200MA 2NS DO-35	28480	1901-0050
A16L1	9140-0158	6		INDUCTOR RF-CH-MLD 1UH 10 .105DX.26LG	28480	9140-0158
A16L2	9140-0158	6		INDUCTOR RF-CH-MLD 1UH 10 .105DX.26LG	28480	9140-0158
A16L3	9140-0158	6		INDUCTOR RF-CH-MLD 1UH 10 .105DX.26LG	28480	9140-0158
A16L4	9140-0158	6		INDUCTOR RF-CH-MLD 1UH 10 .105DX.26LG	28480	9140-0158
A16L5	9100-2247	4		INDUCTOR RF-CH-MLD 100NH 10% .105DX.26LG	28480	9100-2247
A16MP1	08558-20159	7		BOARD-MOTHER	28480	08558-20159
A16MP2	0380-0843	5	1	STANDOFF-RVT-ON .125-IN-LG 4-40THD	00000	ORDER BY DESCRIPTION
A16R1	0757-0424	7		RESISTOR 1.1K 1% .125W F TC=0+-100	24546	C4-1/8-TO-1101-F
A16R2	0757-0465	6		RESISTOR 100K 1% .125W F TC=0+-100	24546	C4-1/8-TO-1003-F
A16R3	0698-5360	2	1	RESISTOR 3.74K .25% .125W F TC=0+-50	28480	0698-5368
A16R4	2100-1757	2		RESISTOR-TRMR 500 5% WW SIDE-ADJ 1-TRN	28480	2100-1757
A16R5	0757-0444	1		RESISTOR 12.1K 17 .125W F TC=0+-100	24546	C4-1/8-TO-1212--F
A16R6	0698-3442	9		RESISTOR 237 1% .125W F TC=0+-100	24546	C4-1/8-TO-237R-F
A16R7	0757-0395	1		RESISTOR 56.2 1% .125W F TC= 0+-100	24546	C4-1/8-TO-56R2-F
A16R8	0698-3260	9		RESISTOR 464K 1% .125W F TC=0+-100	28480	0698-3260
A16TP1	1251-0600	0		CONNECTOR-SGL CONT PIN 1.14-MM-BSC-SZ SQ	28480	1251-0600
A16TP2	1251-0600	0		CONNECTOR-SGL CONT PIN 1.14-MM-BSC-SZ SQ	28480	1251-0600
A16VR1	1902-0625	0	1	DIODE-ZNR 1N829 6.2V 5% DO-7 PD=.25W	04713	1N829
A16VR2	1902-0631	0	1	DIODE-ZNR 1N5351B 6.2V 5% DO-7 PD=.25W	04713	1N5351B
A16VR3	1902-0632	0	1	DIODE-ZNR 1N5354B 6.2V 5% DO-7 PD=.25W	04713	1N5354B
A16VR4	1902-3182	0	1	DIODE-ZNR 1N829 12.1V 5% DO-7 PD=.25W	04713	1902-3182
A16W1	08558-60169	3	1	CABLE ASSY-.REAR PANEL INTERCONNECT	28480	08558-60169
A16W2	08558-60044	3	1	CABLE ASSY-YIG DRIVER	28480	08558-60044
A16W3	08558-60080	7	1	CABLE ASSY-SECOND CONVERTER	28480	08558-60080
A16W4	08558-60081	8	1	CABLE ASSY-DPM DRIVER	28480	08558-60081
A16XA1 THRU A16XA6				NOT ASSIGNED		
A16XA7	1251-1365	6	6	CONNECTOR-PC EDGE 22-CONT/ROW 2-ROWS	28480	1251-1365
A16XA8	1251-1365	6		CONNECTOR-PC EDGE 22-CONT/ROW 2-ROWS	28480	1251-1365
A16XA9	1251-0472	4	2	CONNECTOR-PC EDGE 6-CONT/ROW 2-ROWS	28480	1251-0472
A16XA10	1251-0472	4		CONNECTOR-PC EDGE 6-CONT/ROW 2-ROWS	28480	1251-0472
A16XA11	1251-1365	6		CONNECTOR-PC EDGE 22-CONT/ROW 2-ROWS	28480	1251-1365
A16XA12	1251-1365	6		CONNECTOR-PC EDGE 22-CONT/ROW 2-ROWS	28480	1251-1365
A16XA13	1251-1365	6		CONNECTOR-PC EDGE 22-CONT/ROW 2-ROWS	28480	1251-1365
A16XA14	1251-1365	6		CONNECTOR-PC EDGE 22-CONT/ROW 2-ROWS	28480	1251-1365
A16XA15	1251-2034	8	1	CONNECTOR-PC EDGE 10-CONT/ROW 2-ROWS	28480	1251-2034
A17	08558-60035	2	1	INVERTER	28480	08558-60035
A17C1	11100-0228	6	1	CAPACITOR-FXD 22.UF+-10% 15VDC TA	56289	150D226X9015B2
A17C2	0180-1747	6	1	CAPACITOR-FXD 150UF+-20% 15VDC TA	56289	150D157X0015
A17C3	0160-0128	3	2	CAPACITOR-FXD 2.2UF +-20% 50VDC CER	28480	0160-0128
A17C4	0180-0229	7	1	CAPACITOR-FXD 33UF+-10% 10VDC TA	56289	150D336X9010B2
A17C5	0160-0128	3		CAPACITOR-FXD 2.2UF +-20% 50VDC CER	28480	0160-0128

See introduction to this section for ordering information ,
*Indicates factory selected value

Table 6-3. Replaceable Parts

Reference Designation	HP Part Number	C D	Qty	Description	Mfr. Code	Mfr Part Number
A17C6	0180-1714	7		CAPACITOR-FXD 330UF+-10% 6VDC TA	56289	150D337X9006S2
A17CR1	1901-0620	3	8	DIODE-SWITCHING 60V 400MA DO-35	9N171	NDP250
A17CR2	1901-0620	3		DIODE-SWITCHING 60V 400MA DO-35	9N171	NDP250
A17CR3	1901--0620	3		DIODE-SWITCHING 60V 400MA DO-35	9N171	NDP250
A17CR4	1901-0620	3		DIODE-SWITCHING 60V 400MA DO-35	9N171	NDP250
A17CR5	1901-0620	3		DIODE-SWITCHING 60V 400MA DO-35	9N171	NDP250
A17CR6	1901-0620	3		DIODE-SWITCHING 60V 400MA DO-35	9N171	NDP250
A17CR7	1901-0620	3		DIODE-SWITCHING 60V 400MA DO-35	9N171	NDP250
A17CR8	1901-0620	3		DIODE-SWITCHING 60V 400MA DO-35	9N171	NDP250
A17L1	9100-2552	4	1	INDUCTOR RF-CH-MLD 15UH 10% .161DX .385LG	28480	9100-2552
A17L2	08558-80010	5		COIL, FILTER, ORANGE, 500 UH	28480	08550-80010
A17L3	9100-1618	1		INDUCTOR RF-CH-MLD 5.6UH 10%	28480	9100-1618
A17L4	9100-2552	4		INDUCTOR RF-CH-MLD 15UH 10% .161DX.385LG	28480	9100-2552
A17L5	9100-2552	4		INDUCTOR RF-CH-MLD 15UH 10% .161DX.385LG	28480	9100-2552
A17L6	9140-0096	1	1	INDUCTOR RF-CH-MLD 1UH 10% .166DX.385LG	28480	9140-0096
A17L7	08558-80007	0	2	COIL, FILTER, GREEN, 150 UH	28480	08558-80007
A17L8	08558-80007	0		COIL, FILTER, GREEN, 150 UH	28480	08558-80007
A17NP1	7100-0529	9	1	COVER	28480	7100-0529
A17MP2	7100-0530	2	1	CAN	28480	7100-0530
A17MP3	08558-00049	2	1	INSULATOR, INVERTER	28480	0855EI-00049
A17Q1	1854-0039	7		TRANSISTOR NPN 2N3053S SI TO-39 PD=1W	3L585	2N3053S
A17Q2	1854-0039	7		TRANSISTOR NPN 2N3053S SI TO-39 PD=1W	3L585	2N3053S
A17R1*	0757-0459	8	6	RESISTOR 56.2K 1% .125W F TC=0+-100	24546	C4-1/8-TO-5622-F
A17R2	0757-0180	2		RESISTOR 31.6 1% .125W F TC=0+-100	28480	0757-0100
A17T1	08558-80006	9	1	TRANSFORMER, INVERTER	28480	08558-80006
A17VR1	1902-0551	1	1	DIODE-ZNR 6.2V 5% PD=1W 1R=10UA	28480	1902-0551

See introduction to this section for ordering information

*Indicates factory selected value

Table 6-3. Replaceable Parts

Reference Designation	HP Part Number	C D	Qty	Description	Mfr. Code	Mfr Part Number
				ACCESSORIES SUPPLIED		
	11593A	7	1	TERMINATION-50 OHM	28480	11593A
	1250-0780	5	1	ADAPTER, TYPE N MALE TO BNC FEMALE	28480	1250-0780
	5020-8565	7	1	CRT-OVERLAY, 180-SERIES DISPLAYS	28480	5020-8565
	5020-8566	0	1	CRT-OVERLAY, 181-SERIES DISPLAYS	28480	5020-8566
	5020-8567	9	1	CRT-OVERLAY, 182-SERIES DISPLAYS	28480	5020-8567
	08558-60131	9	1	SIDE STOP KIT	28480	08558-60131
				ELECTRICAL CHASSIS PARTS		
V1	5086-7282	1	1	LIMITER, RF INPUT, THRESH=1MW; MAX 10W, 2WDC	28480	5086-7282
W1	08558-60031	8	1	CABLE ASSY-750 OHM INPUT(OPT.001,002)	28480	08558-60031
W1	08558-60038	5	1	CABLE ASSY-50 OHM INPUT(STD. SEE FIG.6-1)	28480	08558-60038
W2				NOT ASSIGNED		
W3	08558-20071	2	1	CABLE ASSY-1ST LO OUTPUT	28480	08558-20071
W4	08558-20090	5	1	CABLE ASSY-YIG OSC TO FIRST CONVERTER	28480	08558-20090
W5	08558-20073	4	1	CABLE ASSY-FIRST CONVERTER TO SECOND CON	28480	08558-20073
W6	08558-60047	6	1	CABLE ASSY-SECOND CONVERTER TO SECOND IF	28480	08558-60047
W7	08558-60048	7	1	CABLE ASSY-SECOND IF TO THIRD CONVERTER	28480	08558-60048
W8	08558-60046	5	1	CABLE ASSY-50-OHM CAL OUTPUT (STD)	28480	08558-60046
W8	08558-60074	9	1	CABLE ASSY-75-OHM CAL OUTPUT(OPT.001/002)	28480	08558-60074
W9				NOT ASSIGNED		
W10	08557-60045	3	1	CABLE ASSY-VERT. OUTPUT(ON TOP GUIDE RAIL	28480	08557-60045
W11				NOT ASSIGNED		
W12				NOT ASSIGNED		
W13				NOT ASSIGNED		
W14	08558-20117	7	1	CABLE ASSY-ATTEN TO LIMITER	28480	08558-20117
W15	08558-20116	6	1	CABLE ASSY-LIMITER TO FIRST CONVERTER	28480	08558-20116
W16	08558-60170	6	1	CABLE ASSY- PROBE POWER	28480	08558-60170

See introduction to this section for ordering information
 *Indicates factory selected value

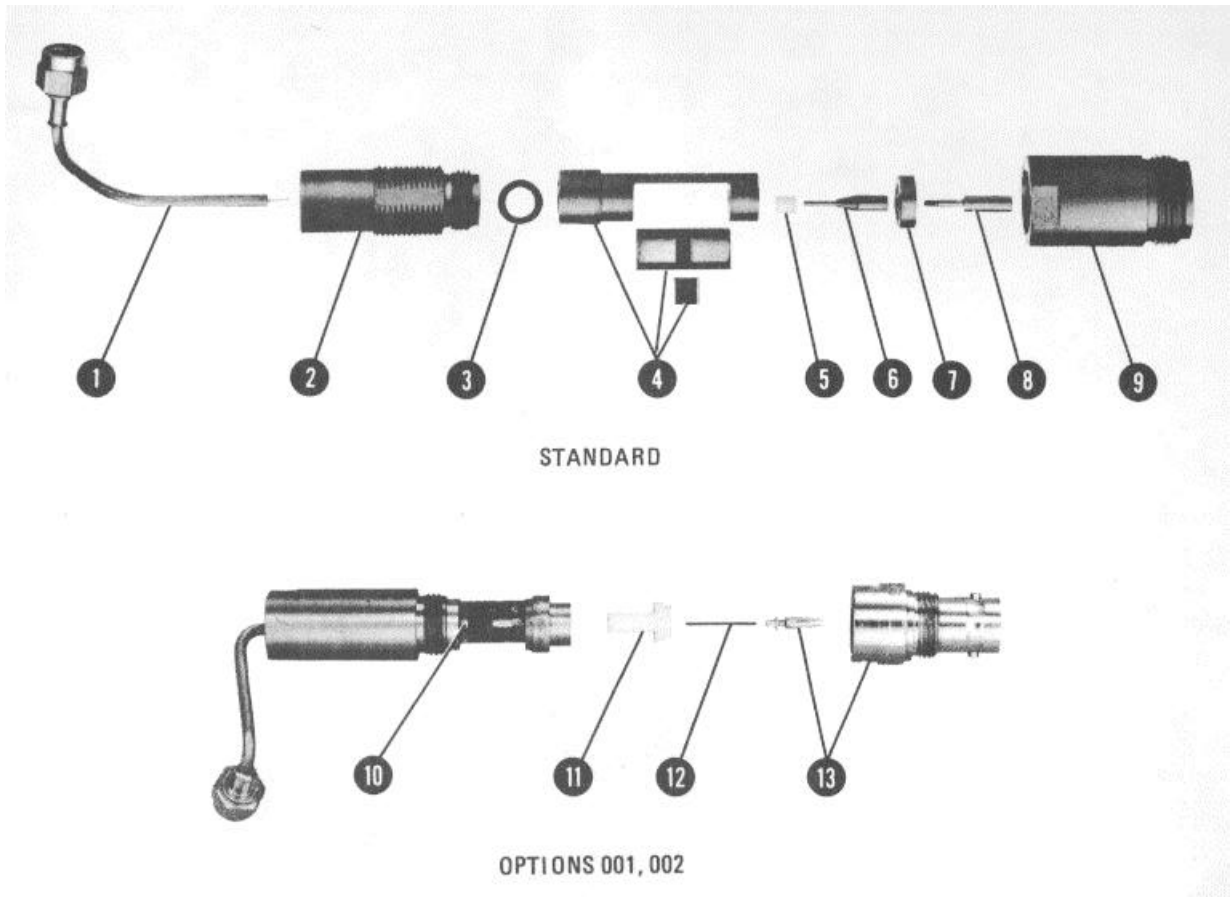

Reference Designation	HP Part Number	C	D	Qty	Description	Mfr. Code	Mfr Part Number
1	08558-20080	3		1	Assy: Cable (Includes W1P1)	28480	08558-20080
2	08558-20079	0		1	Shell: Type-N Capacitor	28480	08558-20079
3	3050-0253	5		1	Washer: Spring	28480	3050-0253
4	08558-60127	3		1	Blocking Capacitor Assy	28480	08558-60127
5	08558-20077	8		1	Dielectric	28280	08558-20077
6	08558-20076	7		1	Conductor: Inner Type-N	28480	08558-20076
7	5040-0306	0		1	Capacitor Insulator	28480	5040-0306
8	1250-0915	8		1	Contact: RF Connector	02660	131-149
9	1250-0914	7		1	Body: RF Connector	02660	131-150
10	0160-3344	1		1	Capacitor: 0.12µF 50 Vdc	28480	0160-3344
11	08558-20101	9		1	Dielectric	28480	08558-20101
12					24 AWG Wire		
13	1250-0505	2		1	RF Connector: 75 ohm (separate white teflon dielectric supplied with connector and pin is not used)	28480	1250-0505

Figure 6-1. Cable Assembly W1 (08558-60038 or 08558-60031) Replaceable Parts

THIS PAGE MISSING NOT AVAILABLE FOR DIGITIZATION.

**PAGES
6-31 through 6-33**

**SECTION VII.
MANUAL BACKDATING CHANGES**

7-1. INTRODUCTION

7-2. This section contains information for adapting this manual to earlier 8558B Spectrum Analyzers. If the serial number prefix of your spectrum analyzer appears on the title page of this manual, the contents of the manual are directly applicable to your instrument. If, however, your spectrum analyzer has a lower serial number prefix than what is shown on the title page, you must adapt this manual to your instrument by changing it as indicated in this section.

7-3. To adapt this manual to your instrument, refer to Table 7-1 and make all the manual changes listed opposite your instrument serial number. Make the changes in the sequence in which they are given.

7-4. If your instrument serial number is not listed on the title page of this manual, or in Table 7-1 below, it may be documented in a yellow MANUAL CHANGES supplement. For additional important information about serial number coverage, refer to INSTRUMENTS COVERED BY MANUAL in Section I.

NOTE

In instruments with serial numbers listed in Table 7-1, some parts have part numbers that are different from those listed in the Replaceable Parts list (Table 6-3) of this manual. Unless otherwise indicated by the 'change' instructions in this section, however, the listed parts are the recommended replacement parts.

Table 7-1. Manual Change Requirements by Serial Number

Serial Number, Prefix or Complete Number	Make Manual Changes:
2145A	A
2142A	A, B
2118A	A,B,C
2024A06643 thru -06691, and 2024A06731 to, but not including, prefix 2118A	A, B, C, D
2024A prefix with suffixes thru 06642	A, B, C, D, E
1926A prefixes and 1914A with suffixes 04747,04918, 04993,05158,05160, 05172, 05228,05229,05252, 05281,05297, 05300, thru 05307,05311,05312, 05313,05316,05318,05320	A, B, C, D, E, F
1914A with suffixes other than those listed above	A, B, C, D, E, F, G

7-5. MANUAL CHANGE INSTRUCTIONS

CHANGE A

Page 6-5, Table 6-3:

Insert Table 7-2 (CHANGE A), A1 Digital Panel Meter parts list, of this section so it precedes the A1A2 list.

Page 6-28, Table 6-3:

Substitute Table 7-3 (CHANGE A) of this section for list of Accessories and Chassis Parts shown in Table 6-3.

Page 6-31, Figure 6-2, Mechanical Chassis Parts:

Substitute Figure 7-1 (CHANGE A) of this section for Figure 6-2.

Page 6-33, Figure 6-3, Front Panel Assembly:

Substitute Figure 7-2 (CHANGE A) in this section for Figure 6-3.

Page 8-26, Figure 8-12, Front Switch Board Assembly A2A1 Component Locations:

Delete Figure 8-12.

Page 8-27, Figure 8-13, Front Switch Assembly A2 Schematic Diagram:

Substitute Figure 7-3 of this section for Figure 8-13.

General:

Change all references to front-panel control INPUT ATTEN (dB) to read 'OPTIMUM INPUT.' In Section III and in the operation booklet, 8558B Spectrum Analyzer Operation, change front panel PUSH TO LOCK to LOCK (rotate clockwise to lock 8558B into mainframe).

Change description of OPTIMUM INPUT (changed from INPUT ATTEN) control function to read: 'The optimum and maximum input level selected is designated by the pointer behind the control. Push in control knob and turn it to select the required input level range.'

Use table below to translate input attenuation levels given in manual to optimum input levels.

INPUT ATTEN (dB)	OPTIMUM INPUT	OPTION 001	OPTION 002
0	-40 dBm	-35 dBm	15 dBmV
10	-30 dBm	-25 dBm	25 dBmV
20	-20 dBm	-15 dBm	35 dBmV
30	-10 dBm	-5 dBm	45 dBmV
40	0 dBm	5 dBm	55 dBmV
50	10 dBm	15 dBm	65 dBmV
60	20 dBm	25 dBm	75 dBmV
70	30 dBm	30 dBm	80 dBmV

CHANGE B

Page 5-6, Table 5-1:

Add adjustment LOG GAIN, A14R1, paragraph 7-6, adjusts dc offset circuitry at output of Log Amplifier for 10 dB steps in Log mode.

Add adjustment LOG/LIN, A14R2, paragraph 7-6, adjusts for Log-to-linear full-screen display translations.

Add adjustment LIN GAIN, A14R3, paragraph 7-6, adjusts Log Amplifier for 10 dB gain steps in Linear mode. Affects adjustment of LOG/LIN.

7-5. MANUAL CHANGE INSTRUCTIONS (Cont'd)**CHANGE B (Cont'd)**

Page 5-45, Paragraph 5-26, Figure 5-13:

Substitute paragraph 7-6, LOG AMPLIFIER LOG AND LINEAR ADJUSTMENT (CHANGE B) in this section for paragraph 5-26, and Figure 7-4 (CHANGE B) for Figure 5-13.

Pages 6-21 through 6-24, Table 6-3:

Replace entire A14 Replaceable Parts list (A14 through A14VR1) with Table 7-7 (CHANGE B) of this section.

Page 6-31, Figure 6-2, Mechanical Chassis Parts:

Change item 30 to HP Part Number 08558-00086, Check Digit 7.

Page 8-84, Figure 8-37, A14 Log Amplifier Component and Test Point Locations:

Replace Figure 8-37 with Figure 7-5 (CHANGE B) of this section.

Pages 8-85/8-86 and 8-87/8-88, Figure 8-38, A14 Log Amplifier Schematic:

Replace Figure 8-38 with Figure 7-6 (2 sheets) (CHANGE B) of this section.

CHANGE C

Page 1-3, Table 1-1:

Under **Calibrator Output**, change ± 300 kHz' to ± 50 kHz.'

Page 1-8, Table 1-2:

Under **Cal Output**, change text to read as follows:

'-30 dBm, 280 MHz with 2nd through 5th harmonics greater than -60 dBm.

002: + 20 dBm V, 280 MHz with 2nd through 5th harmonics greater than - 10 dBm V.'

Page 6-12, Table 6-3:

Change A9C5 to HP Part Number 0150-2251, Check Digit 6, Qty 1, CAPACITOR-FXD 5.6PF $\pm .25$ PF.

Delete A9C20

Page 6-14, Table 6-3:

Add A9Y1, HP Part Number 0410-0447, Check Digit 0, Qty 1, CRYSTAL-QUARTZ

FREQ = 280 MHz 11th OVERTONE.

Delete A9Z 1.

Page 8-60, Figure 8-25:

Replace Figure 8-25 with Figure 7-7 (CHANGE C) of this section.

Page 8-61, Figure 8-26:

Replace function block A with function block A shown in Figure 7-8 (CHANGE C) of this section.

CHANGED

Page 6-14, Table 6-3:

Change A11C14 to HP Part Number 0160-2253, Check Digit 9, Qty 1, CAPACITOR-FXD 6.8PF $\pm .25$ PF 500VDC CER, 28480, 0160-2253.

Change A11C37 to HP Part Number 0160-2252, Check Digit 8, Qty 1, CAPACITOR-FXD 6.2PF $\pm .25$ PF 500VDC CER, 28480, 0160-2252.

7-5. MANUAL CHANGE INSTRUCTIONS (Cont'd)**CHANGE D (Cont'd)**

Pages 6-18, and 6-19, Table 6-3:

Change A13C14 to HP Part Number 0160-2253, Check Digit 9, Qty 1, CAPACITOR- FXD 6.8PF± .25PF 500VDC CER, 28480, 0160-2253.

Change A13C37 to HP Part Number 0160-2252, Check Digit 8, Qty 1, CAPACITOR-FXD 6.2PF±.25PF 500VDC CER, 28480, 0160-2252.

Page 8-69, Figure 8-30, A11 Bandwidth Filter No. 1 Schematic:

Change value of C14 to 6.8PF, and value of C37 to 6.2PF.

Page 8-79, Figure 8-35, A13 Bandwidth Filter No. 2 Schematic:

Change value of C14 to 6.8PF, and value of C37 to 6.2PF.

CHANGE E

Page 6-26, Table 6-3:

Delete A16C9 and A16C10.

Page 8-97, Figure 8-44:

Delete C9 and C10.

CHANGE F

Page 5-7, Table 5-2:

Change A9R14 to A9R25.

Pages 6-12 and 6-13, Table 6-3:

Delete A9C17, A9C18, A9C19, A9CR7, A9L15, and A9L16.

Change A9R12* (standard instrument) to HP Part Number 0698-3132, Check Digit 4, Qty 1, RESISTOR 261 1% .125W F TC=0 ± 100, 24546, C4-1/8-TO-2610-F.

Change A9R14* to A9R14, HP Part Number 0757-0462, Check Digit 3, Qty 1, RESISTOR 75K 1% .125W F TC = 0 ± 100, 24546, C4-1/8-TO-7502-F.

Change A9R25 to A9R25*.

Page 8-60, Figure 8-25:

Replace Figure 8-25 with Figure 7-9 of this section.

Pages 8-57, and 8-58:

Replace circuit descriptions for 21.4 MHz Amplifier (E) and PIN Driver (F) with the circuit descriptions provided below.

21.4 MHz Amplifier E

The 21.4 MHz Amplifier consists of A9Q3 in a common-emitter configuration and A9Q4 as an emitter follower. Transistor A9Q3 employs resistor A9R12 and zener diode A9VR2 to furnish base bias and negative feedback for gain control and stabilization. Resistor A9R12 is factory selected to provide the proper gain of the third converter assembly. Capacitor A9C14 is connected across A9VR2 to reduce zener noise. The output of the 21.4 MHz Amplifier looks into a voltage-controlled attenuator consisting of two PIN diodes, A9CR3 and CR4, resistor A9R25, and the input impedance of the A11 Bandwidth Filter No. 1.

7-5. MANUAL CHANGE INSTRUCTIONS (Cont'd)**CHANGE F (Cont'd)****PIN Driver (F)**

The PIN diode resistance of A9CR3 and CR4 is controlled by the PIN driver A9Q5 and its associated circuitry. The base of A9Q5 is the summing point for the frequency analog voltage from the A7 Frequency Control and a dc level set by the front-panel REF LEVEL CAL screwdriver adjustment A2R3. Setting the dc level by adjusting A2R3 calibrates the 8558B display at a given frequency, usually performed at 280 MHz. The frequency analog voltage is a dc level varying from + 0.6 volts to + 6.7 volts as a function of frequency. This frequency analog voltage at the base of A9Q5 compensates for input mixer response. SLOPE COMP adjustment A9R1 sets the amount of compensation required for a flat frequency response. The total current through the PIN diodes A9CR3 and CR4 is shaped by the emitter network of A9Q5. This network provides a change in current through the PIN diodes to cause a change of PIN diode resistance. The change in resistance is required to provide the proper log curve within an 8 dB range for the voltage-controlled attenuator.

Page 8-61, Figure 8-26:

Replace function block E and F with function blocks E and F shown in Figure 7-10 (CHANGE F).

CHANGE G

Page 7-11, Figure 7-2:

Change item 53 HP Part Number to 08558-20052, Check Digit 9.
Change item 57 on HP Part Number 08552-20053, Check Digit 0.

Table 7-2. Replaceable Parts (CHANGE A)

Reference Designation	HP Part Number	C D	Qty	Description	Mfr. Code	Mfr Part Number
A1				DIGITAL PANEL METER ASSEMBLY		
A1MP1	08558-00090	3	1	BRACKET, LEFT-HAND	28480	08558-00090
A1MP2	08558-00091	4	1	BRACKET, RIGHT-HAND	28480	08558-00090
A1MP3	08558-20130	4	2	DPM DISPLAY MOUNT	28480	08558-20130
A1MP4	08558-20130	4		DPM DISPLAY MOUNT	28480	08558-20130
A1MP5	2200-0107	6	4	SCREW-MACH 4-40.375-IN-LG PAN-HD-POZI	28480	2200-0107
A1MP6	2200.0107	6		SCREW-MACH 4-40.375-IN-LG PAN-HD-POZI	28480	2200-0107
A1MP7	2200-0107	6		SCREW-MACH 4-40.375-IN-LG PAN-HD-POZI	28480	2200-0107
A1IMP8	2200-0107	6		SCREW-MACH 4-40.375-IN-LG PAN-HD-POZI	28480	2200-0107
A1MP9 THRU A1MP16	0520-0174 3		1 8	SCREW-MACH 2-56 .25-IN-LG PAN-HD-POZI	28480	0520-0174
A1MP17 THRU A1MP20	0610-0001	6	4	NUT-HEX-DBL-CHAM 2-56-THD.062-IN-THK	28480	0610-0001
A1MP21 THRU A1MP24	2190-0890	1	4	WASHER-LK MTCL NO. 2.088-IN-ID	28480	2190-0890
A1MP25 THRU A1MP28	3050-0098	6	4	WASHER-FL MTLC NO. 2.094-IN-ID	28480	3050-0098
A1A1	08558-60124	0	1	DPM DISPLAY	28480	08558-60124
A1A1DS1	1990-0619	7	4	DISPLAY-NUM-SEG 1-CHAR .3-H	28480	5082-7613
A1A1DS2	1990-0619	7		DISPLAY-NUM-SEG 1-CHAR .3-H	28480	5082-7613
A1A1DS3	1990-0619	7		DISPLAY-NUM-SEG 1-CHAR .3-H	28480	5082-7613
A1A1DS4	1990-0619	7		DISPLAY-NUM-SEG 1-CHAR .3-H	28480	5082-7613
A1A1W1	08558-60130	8	1	CABLE ASSY RIBBON, DPM	28480	08558-60130
A1A1XDS1	1200-0693	4	4	SOCKET-IC 10-CONT DIP DIP-SLDR	51167	10-513-11
A1A1XDS2	1200-0693	4		SOCKET-IC 10-CONT DIP DIP-SLDR	51167	10-513-11
A1A1XDS3	1200-0693	4		SOCKET-IC 10-CONT DIP DIP-SLDR	51167	10-513-11
A1A1XDS4	1200-0693	4		SOCKET-IC 10-CONT DIP DIP-SLDR	51167	10-513-11

Table 7-3. Replaceable Parts (CHANGE A)

Reference Designation	HP Part Number	C D	Qty	Description	Mfr. Code	Mfr Part Number
				ACCESSORIES SUPPLIED		
AT1	11593A	7	1	TERMINATION, 50 OHM	28480	11593A
	1250-0780	5	1	ADAPTER, TYPE N MALE TO BNC FEMALE	28480	1250-0780
	5020-8565	7	1	OVERLAY, 180 SERIES SCOPES	28480	5020-8565
	5020-8566	8	1	OVERLAY, 181 SERIES SCOPES	28480	5020-8566
	5020-8567	9	1	OVERLAY, 182 SERIES SCOPES	28480	5020-8567
	08558-60131	9	1	KIT, SIDE STOP	28480	08558-60131
				CHASSIS PARTS		
P1	08558-60117	1	1	REAR-PANEL INTERCONNECT (PREWIRED)	28480	08558-60117
R1	2100-3593	8	1	RESISTOR-VAR PREC W/CP 10-TRN 5K 10%	28480	2100-3593
R2	2100-3452	8	1	RESISTOR-VAR PREC W/CP 10-TRN 10K 10%	28480	2100-3452
R3	2100-3066	0	1	RESISTOR-VAR PREC WW 10-TRN 5K 5%	28480	2100-3066
R4	2100-0542	1	1	RESISTOR-VAR CONTROL WW 10K 5% LIN	28480	2100-0542
R5	2100-3317	4	2	RESISTOR-VARIABLE W/SW 50K +-20% 10CW	28480	2100-3317
R6	2100-3317	4		RESISTOR-VARIABLE W/SW 50K +-20% 10CW	28480	2100-3317
S1	3101.0044	1	1	SWITCH-PB SPST-NO MOM .5A 115VAC RED-BTN	28480	3101-0044
U1	5086-7282	1	1	LIMITER, RF INPUT	28480	5086-7282
W1	08558-60038	5	1	CABLE ASSY, INPUT, RF(SEE FIG. 6-1)	28480	08558-60038
W1	08558-60031	8	1	CABLE ASSY, INPUT, RF (OPT. 001/002)	28480	08558-60031
W2				NOT ASSIGNED		
W3	08558-20071	2	1	CABLE ASSY, OUTPUT, L.O.	28480	08558-20071
W4	08558-20090	5	1	CABLE ASSY, INPUT, 1ST L.O.	28480	08558-20090
W5	08558-20073	4	1	CABLE ASSY, OUTPUT, 1ST I.F.	28480	08558-20073
W6	08558-20047	6	1	CABLE ASSY, INPUT, 2ND I.F.	28480	08558-60047
W7	08558-20048	7	1	CABLE ASSY, OUTPUT, 2ND I.F.	28480	08558-60048
W8	08558-20046	5	1	CABLE ASSY, CAL OUTPUT	28480	08558-60046
W8	08558-20074	9	1	CABLE ASSY, CAL OUTPUT (OPT. 001/002)	28480	08558-60074
W9	08558-60037	4	1	CABLE ASSY, INTERCONNECT	28480	08558-60037
W10	08558-60043	2	1	CABLE ASSY, OUTPUT, VERTICAL	28480	08558-60043
W11				NOT ASSIGNED		
W12	08558-60044	3	1	CABLE ASSY, YIG DRIVER	28480	08558-60044
W13	08558-60080	7	1	CABLE ASSY, SECOND CONVERTER	28480	08558-60080
W14	08558-20117	7	1	CABLE ASSY, ATTENUATOR TO LIMITER	28480	08558-20117
W15	08558-20116	6	1	CABLE ASSY, LIMITER TO FIRST CONVERTER	28480	08558-20116

See introduction to this section for ordering information

*Indicates factory selected value

Reference Designation	HP Part Number	C D	Qty	Description	Mfr. Code	Mfr Part Number
MECHANICAL CHASSIS PARTS						
1	08558-00002	7	1	PANEL, FRONT, SUP	28480	08558-00002
2	08558-00004	9	1	GUSSET, LEFT	28480	08558-00004
3	08558-00005	0	1	GUSSET, RIGHT	28480	08558-00005
4	08558-00003	8	1	PANEL, REAR	28480	08558-00003
5	08558-20039	2	1	GUIDE RAIL, LEFT	28480	08558-20039
6	08558-20040	5	1	GUIDE RAIL, RIGHT	28480	08558-20040
7	08558-20037	0	1	EXTRUSION, END PLATE ENCLOSURE	28480	08558-20037
8	08558-20036	9	1	EXTRUSION, CIRCUIT ENCLOSURE, TAPPED (4)	28480	08558-20036
9	08558-20051	7	2	EXTRUSION, CIRCUIT ENCLOSURE	28480	08558-20051
10	08558-20038	1	1	EXTRUSION, ENCLOSURE DIVIDER	28480	08558-20038
11	08558-40015	6	1	HOUSING, LATCH (FOR INSTRUMENTS WITH SERIAL PREFIX 13344 & BELOW, SEE SECTION VII)	28480	08558-40015
12	08558-20092	7	1	SHIFT, LATCH	28480	08558-20092
13	08558-20030	1	1	INSULATOR, BOTTOM GUIDE RAIL	28480	08558-00030
14	08558-20041	6	1	GUIDE RAIL, BOTTOM	28480	08558-20041
15	08558-20027	8	1	BOARD, VERTICAL OUTPUT CONNECTOR	28480	08558-20027
16	0624-0203	9	8	SCREW-TPG 4-40 .375-IN-LG 82 DEG	28480	0624-0203
17	2200-0055	3	1	SCREW-MACH 4-40 .125-IN-LG 82 DEG	28480	2200-0055
18	2200-0104	3	17	SCREW-MACH 4-40 .25-IN-LG 82 DEG	28480	2200-0104
19	2360-0210	0	4	SCREW-MACH 6-32 .625-IN-LG 82 DEG	28280	2360-0210
20	0624-0268	6	40	SCREW-TPG 4-24 .375-IN-LG PAN-HD-POZI	28480	0624-0268
21	0624-0206	2	1	SCREW-TPG 6-32 .25-IN-LG PAN-HD-POZI STL	28480	0624-0206
22	2200-0103	2	4	SCREW-MACH 4-40 .25-IN-LG PAN-HD-POZI	28480	2200-0103
23	2360-0115	4	1	SCREW-MACH 6-32 .31 2-IN-LG PAN-HD-POZI	28480	2360-0115
24	2200-0170	3	2	SCREW-MACH 4-40 .625-IN-LG 82 DEG	28480	2200-0170
25	0380-0006	2	2	SPACER-RND .375-IN-LG .18-IN-ID	28480	0380-0006
26	2260-0003	7	2	NUT.HEX-PLSTC LKG 4-40-THD .141-IN.-THK	28480	2260-0003
27	2200-0107	2		SCREW-MACH 4-40 .375IN-LG PAN-HD-POZI	28480	2200-0107
28	2200-0164	5	7	SCREW-MACH 4-40 .188-IN.LG UNCT 82 DEG	28480	2200-0164
29	2200-0168	9	3	SCREW-MACH 4-40 .438-IN-LG 82 DEG	28480	2200-0168
30	08558-00086	7	1	COVER, LOG AMPLIFIER	28480	08558-00086
31	08558-00089	0	2	COVER, BANDWIDTH FILTER NO. 1	28480	08558-00089
32	08558-00088	9	1	COVER, STEP GAIN	28480	08558-00088
33	08558-00087	8	1	COVER, BANDWIDTH FILTER NO. 2	28480	08558-00087
34	08565-20096	0	1	EXTRUSION, CIRCUIT ENCLOSURE,TAPPED (8)	28480	08565-20096
35	08565-20093	7	1	EXTRUSION, CIRCUIT ENCLOSURE,TAPPED (4)	28480	08565-20093

Figure 7-1. Mechanical Chassis Parts (1 of 2) (CHANGE A)

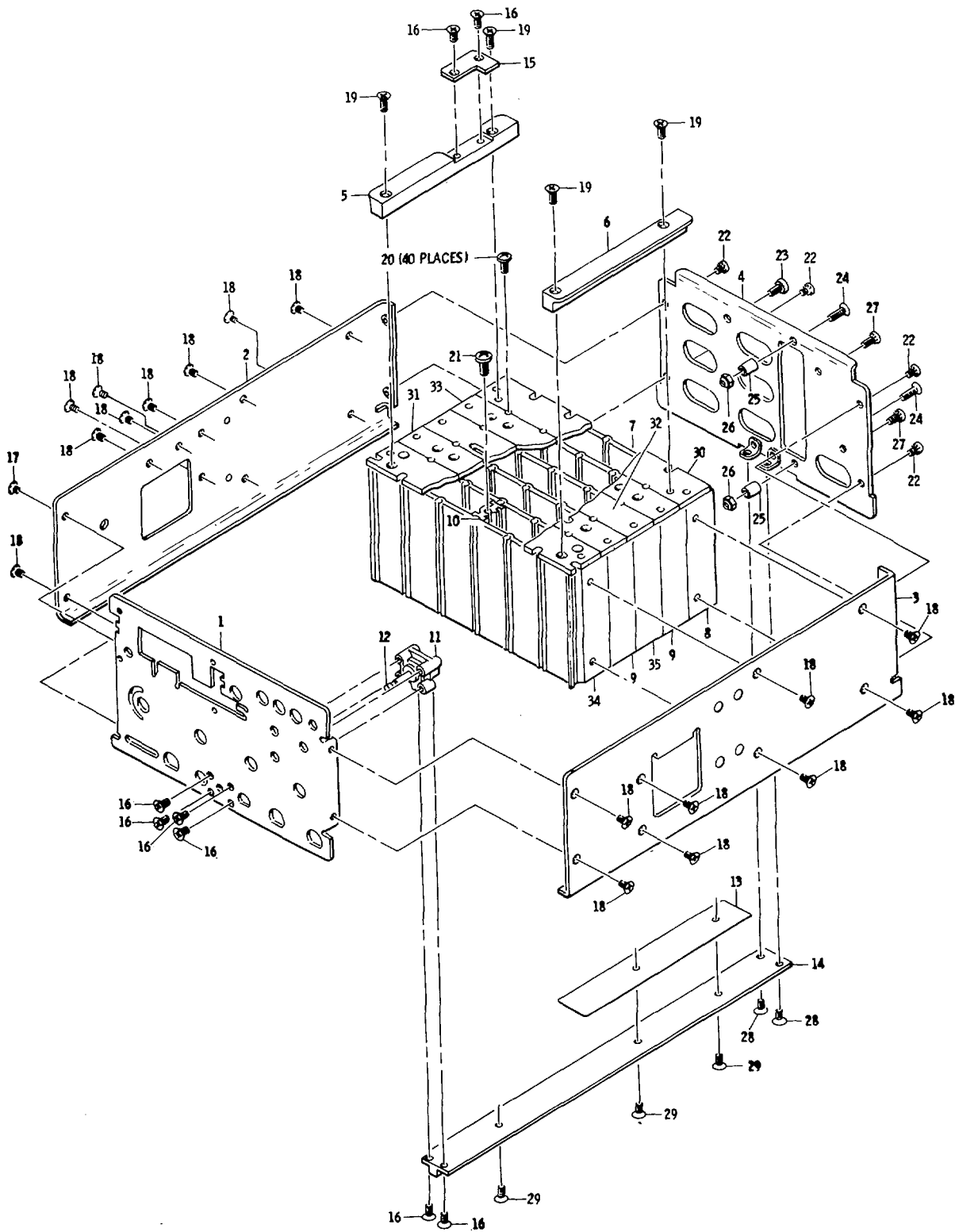

Figure 7-1. Mechanical Chassis Parts (2 of 2) (CHANGE A)

Reference Designation	HP Part Number	C D	Qty	Description	Mfr. Code	Mfr Part Number
				FRONT PANEL ASSEMBLY		
1	08558-00036	7	1	KNOB, REF LEVEL FINE	28480	08558-00036
2	3030-0007	5	33	SCREW-SET 4-40 .125-IN-LG SMALL CUP-PT	28480	3030-0007
3	0510-0089	8	1	RETAINER-RING BSC EXT .188-IN-DIA BE-CU	28480	0510-0089
4	08558-00017	4	1	DISC, INDEX	28480	08558-00017
4	08558-00055	0	1	DISC, INDEX (OPTION 002)	28480	08558-00055
5	3050-0032	8	1	WASHER-FL MTLT NO. 8 .189-IN-ID	28480	3050-0032
6	08558-60050	1	1	KNOB, REF LEVEL	28480	08558-60050
6	08558-60072	7	1	KNOB, REF LEVEL (OPTION 002)	28480	08558-60072
7	3030-0022	4	10	SCREW-SET 6-32 .125-IN-LG SMALL CUP-PT	28480	3030-0022
8	08558-00043	9	1	NUT	28480	08558-00043
9	08558-00018	5	1	POINTER, ATTENUATOR	28480	08558-00018
10	08558-00038	9	1	KNOB, DIAL, RESOLUTION	28480	08558-00038
11	08558-60051	2	1	KNOB, FREQUENCY	28480	08558-60051
12	00180-67402	9	1	KNOB, FINE TUNING	28480	00180-67402
13	08558-00043	6	1	KNOB, COARSE TUNING	28480	08558-00043
14	08558-40003	2	1	WINDOW, DBM	28480	08558-40003
15	2950-0043	8	9	NUT-HEX-DBL-CHAM 3/8-32-THD .094-IN-THK	28480	2950-0043
16	2190-0016	3	13	WASHER-LK INTL T 3/8 IN .377-IN-ID	28480	2190-0016
17	1410-0721	4	1	BUSHING PNL .265-ID .47-LG 3/8-32-THD	28480	1410-0721
18	08558-40001	0	1	SLIDER, REF LEVEL	28480	08558-40001
19	2200-0781	2	3	SCREW-MACH 4-40 2.75-IN-LG PAN-HD-POZI	28480	2200-0781
20	08558-00019	6	3	DETENT, ATTENUATOR	28480	08558-00019
21	0380-0411	3	14	SPACER-RND .5-IN-LG .114-IN-ID	28480	0380-0411
22	08558-20047	2	4	BUSHING, PANEL	28480	08558-20047
23	08558-20051	8	1	SHAFT, REF LEVEL	28480	08558-20051
24	1410-0006	8	6	BALL-BRG TYPE .1875-DIA GRADE-50 SST	28480	1410-0006
25	1460-0578	4	5	SPRING-CPRSN .18-IN-OD .312-IN-DA-LG MUW	28480	1460-0578
26	08559-60060	4	6	HUB ASSEMBLY	28480	08559-60060
27	1480-0367	1	1	PIN-DWL ANSI-UNHDND/GND .0625-IN-DIA	28480	1480-0367
28	1480-0059	8	10	PIN-ROLL .062-IN-DIA .25-IN-LG STL	28480	1480-0059
29	08558-40011	1	1	ROTOR, ATTENUATOR DRIVE	28480	08558-40011
30	08558-40008	1	1	GEAR, 45 TEETH	28480	08558-40008
31	0510-0015	2	2	RETAINER-RING E-R EXT .125-IN-DIA STL	28480	0510-0015
32	08558-60046	2	2	CABLE, CAL OUTPUT	28480	08558-60046
32	08558-60074			CABLE, CAL OUTPUT, 75 OHM (OPT. 001/002)	28480	08558-60074
33	2200-0509	1	1	SCREW-MACH 4-40 1.625-IN-LG PAN-HD-POZI	28480	2200-0509
34	2200-0125	1	1	SCREW-MACH 4-40 1.5-IN-LG PAN-HD-POZI	28480	2200-0125
35	08558-00024	2	2	DETENT, SWEEP TIME	28480	08558-00024
36	08558-20050	1	1	SHAFT, SWEEP WIDTH	28480	08558-20050
37	08558-20066	1	1	ROTOR, FREQUENCY SPAN	28480	08558-20066
38	08558-20089	2	1	BUSHING, SLOTTED	28480	08558-20089
39	1460-1376	2	1	SPRING-TRSN MUW	28480	1460-1376
40	08558-20088	1	1	GEAR, 20 TEETH	28480	08558-20088
41	0520-0139	0	2	SCREW-MACH 2-56 .875-IN-LG PAN-HD-POZI	28480	0520-0139
42	0380-0487	3	2	SPACER-RND .625-IN-LG .086-IN-ID	28480	0380-0487
43				NOT ASSIGNED	28480	
44	0610-0002	7	2	NUT, HEX-BL-CHAM 2-56-THD .062-IN-LG	28480	0610-0002
45	08558-20002	9	1	BOARD, FRONT SWITCH	28480	08558-20002
46	08558-40005	4	3	ROTOR, DOUBLE CONTACT	28480	08558-40005
47	3050-0017	9	3	WASHER-FL MTLT ¼ IN .26-IN-ID	28480	3050-0017
48	1460-0532	0	1	SPRING-CPRSN .54-IN-OD .45-IN-DA-LG MUW	28480	1460-0532
49	2200-0165	6	4	SCREW-MACH 4-40 .25-IN-LG 82 DEG	28480	2200-0165
50	08558-00020	9	1	DETENT, IF GAIN	28480	08558-00020
51	08558-20061	0	1	LOCKOUT, ROTATING	28480	08558-20061
52	08558-20062	1	1	LOCKOUT, FIXED	28480	08558-20062
53	08558-20052	9	1	SHAFT, FIXED	28480	08558-20052
54	2260-0002	6	18	NUT-HEX-DBL-CHAM 4-40-THD .062-IN-THK	28480	2260-0002
55	0380-0413	5	3	SPACER-RND 1.25-IN-LG .114-IN-ID	28480	0380-0413
56	08558-00022	1	1	CRANK, SLOTTED	28480	08558-00022
57	08558-20053	0	1	SHAFT, REF LEVEL FINE	28480	08558-20053
58	1490-0841	7	1	COUPLER-RGD .375-LG BRS	28480	1490-0841
59	2950-0006	3	4	NUT-HEX-DBL-CHAM ¼-32-THD .094-IN-THK	28480	2950-0006
60	2190-0027	6	6	WASHER-LK INTL T ¼ IN .256-IN-ID	28480	2190-0027
61	08558-00021	0	1	PLATE, LEVEL POT	28480	08558-00021
62	2190-0019	6	1	WASHER-LK HLCL NO. 4 .115-IN-ID	28480	2190-0019
63	08558-20054	1	1	SHAFT, ATTENUATOR DRIVE	28480	08558-20054
64	1430-0036	6	2	GEAR-MIT 16-T 32-DP 20-DEG PA BRS	28480	G462Y (MOD)
65				NOT ASSIGNED	28480	
66	08558-00081	2	1	BRACKET, ATTENUATOR	28480	08558-00081
67	3050-0105	6	4	WASHER-FL MTLT NO. 4 .125-IN-ID	28480	3050-0105
68				NOT ASSIGNED	28480	
69	08558-20030	3	1	BOARD, REAR SWITCH	28480	08558-20030
70	2200-0143	0	2	SCREW-MACH 4-40 .375-IN-LG PAN-HD-POZI	28480	2200-0143
71	08558-40004	3	1	ROTOR, SINGLE CONTACT	28480	08558-40004
72	08558-00025	4	1	DETENT, BANDWIDTH	28480	08558-00025

Figure 7-2. Front Panel Assembly (1 of 3) (CHANGE A)

THIS PAGE MISSING NOT AVAILABLE FOR DIGITIZATION.

PAGES
7-11 through 7-14

ADJUSTMENTS

7-6. LOG AMPLIFIER LOG AND LINEAR ADJUSTMENT (CHANGE B)

REFERENCE

A14 and A15 Schematics

DESCRIPTION

10 dB/DIV and LIN are adjusted for correct steps and full-screen display translations.

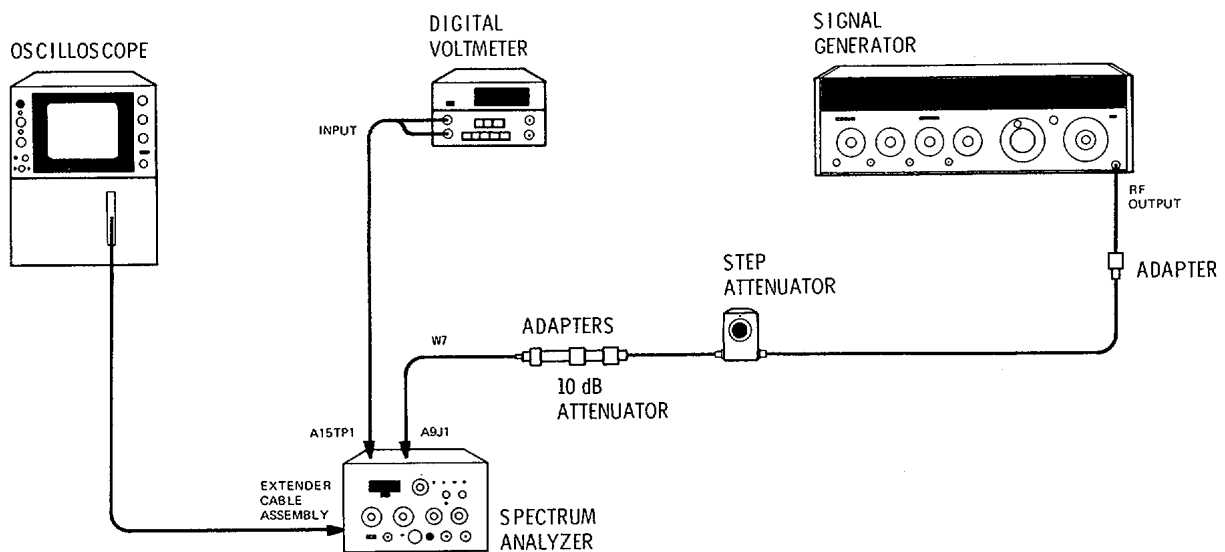

Figure 7-4. Log Amplifier Log and Linear Adjustment Test Setup (CHANGE B)

EQUIPMENT

Signal Generator.....	HP 8640B
Digital Voltmeter.....	HP 34740A/34702A
10 dB Attenuator.....	HP 8491A, Option 010
Step Attenuator (10 dB/step).....	HP 355D
Adapter, Type N Male on one end, BNC Female on other end (2 required).....	HP 1250-0780
Adapter, Type N Female on both ends.....	HP 1250-0777
Adapter, Type N Male on one end, SMC Male on other end.....	HP 1250-1023

ADJUSTMENTS

7-6. LOG AMPLIFIER LOG AND LINEAR ADJUSTMENT (CHANGE B) (Cont'd)

PROCEDURE

1. Set spectrum analyzer controls as follows:

FREQ SPAN/DIV1 MHz
 RESOLUTION BW300 kHz
 OPTIMUM INPUT- 30 dBm
 001: - 25 dBm
 002: + 25 dBm V
 REFERENCE LEVEL dBm.....- 50
 002: 0 dBm V
 10 dB/DIV - 1 dB/DIV - LIN.....LIN
 SWEEP TIME/DIVAUTO
 SWEEP TRIGGER.....FREE RUN

2. Connect equipment as shown in Figure 7-4. Set signal generator frequency to 301.4 MHz and output level to - 13 dBm. Remove W7P1 from Second IF assembly A10J2. Connect signal generator output through step attenuator, 0 dB attenuator, and adapters to W7P1.

NOTE

The 10 dB attenuator is included to compensate for the 10 dB of gain on A12 Step Gain assembly when the TEST-NORM switch is in TEST.

3. Set the TEST-NORM switch on A12 Step Gain assembly to the TEST position. Tune signal generator frequency for maximum signal amplitude on oscilloscope display with step attenuator set at 0 dB.
4. Set output level of signal generator for a digital voltmeter reading of 700 mV, with step attenuator set at 0 dB and REFERENCE LEVEL control set to - 50 dBm.
 002: 0 dBm V
5. Set 8558B REFERENCE LEVEL to - 80 dBm and set step attenuator to 30 dB. Observe digital voltmeter reading.
 002: - 30 dBm V
6. Adjust A14R3 LIN GAIN for a digital voltmeter reading of 700 mV.
7. Repeat steps 4, 5, and 6 until the DVM reading in step 5 is 700 +2 . mV.
8. Set 8558B REFERENCE LEVEL to -50 dBm and set step attenuator to 0 dB. Change REFERENCE LEVEL and step attenuator settings as shown in Table 7-4. If Deviation From Reference is not within the given limits, readjust A14R3.

002: Set REFERENCE LEVEL dBm V to 0 and set attenuator to 0 dB. REFERENCE LEVEL (dBmV) settings in Table 5-7 top to bottom are, 0, -10, -20, -30, -40.

ADJUSTMENTS

7-6. LOG AMPLIFIER LOG AND LINEAR ADJUSTMENT (CHANGE B) (Cont'd)

Table 7-4. Linear Gain Adjustment Limits

Reference Level (dBm)	Step Attenuator Setting (dB)	Deviation From Reference
-50	0	Reference
-60	10	$\pm 0.2 \text{ DIV} \pm 20 \text{ mV}$
-70	20	$\pm 0.2 \text{ DIV} \pm 20 \text{ mV}$
-80	30	$\pm 0.2 \text{ DIV} \pm 20 \text{ mV}$
-90	40	$\pm 0.3 \text{ DIV} \pm 30 \text{ mV}$

9. Set 8558B REFERENCE LEVEL to 0 dBm and disconnect signal generator from step attenuator. Record offset reading (DVM). The offset should be less than + 30 mV.
002: REFERENCE LEVEL, +50 dBm V
10. Reconnect signal generator as shown in Figure 7-3. Set 10 dB/DIV - 1 dB/DIV - LIN switch to 10 dB/DIV and set step attenuator to 40 dB.
11. Set output level of signal generator for a digital voltmeter reading of 400 mV plus offset recorded in step 9 (algebraic sum). (Example: If offset is - 23 mV, set output level of signal generator for a DVM reading of 377 mV.)
12. Set step attenuator to 0 dB. Digital voltmeter should indicate 800 mV, plus offset (algebraic sum) ± 1 mV. If DVM reading is not within limits, adjust A14R2 LOG/LIN adjustment for a digital voltmeter reading of 800 mV, plus offset minus 50 percent of overshoot. Example: If DVM indicates 767 mV and should be indicating 777 mV (-10 mV overshoot), adjust A14R2 for a DVM reading of 777 mV minus - 5 mV, or 782 mV.
13. Repeat steps 10, 11, and 12 until the digital voltmeter indicates 800 mV plus offset ± 1 mV with no further adjustment of A14R2 in step 12.
14. Set the step attenuator to the positions shown in Table 7-5 and record DVM reading for each setting. Correct the DVM readings by algebraically adding the offset (recorded in step 9).
15. Readjust A14R2 if necessary to meet the limits in Table 7-5.
16. Set step attenuator to 0 dB and set output level of signal generator for a digital voltmeter reading of 800 mV plus offset (recorded in step 9) ± 1 mV.
17. Set 10 dB/DIV - 1 dB/DIV - LIN switch to LIN. The digital voltmeter should indicate the reading set in step 16 ± 5 mV. If it does, go to step 19. If it does not, or if log fidelity is not within limits, go to step 18 and select A14R16*.

ADJUSTMENTS

7-6. LOG AMPLIFIER LOG AND LINEAR ADJUSTMENT (CHANGE B) (Cont'd)

Table 7-5. Log Fidelity Check

Step Attenuator Setting (dB)	DVM Reading (mV)	DVM Reading Corrected For Offset		
		Min. (mV)	Actual (mV)	Max. (mV)
0	_____	799	_____	801
10	_____	697	_____	703
20	_____	596	_____	604
30	_____	496	_____	504
40	_____	395	_____	405
50	_____	294	_____	306
60	_____	193	_____	207
70	_____	92	_____	108

18. Select A14R16* to obtain an output in step 17 within ± 25 mV of the reading set in step 16. Decreasing A14R16* 10 percent will increase the DVM reading approximately 30 mV in step 17.

NOTE

Log fidelity must be considered when selecting A14R16*. That is, if the DVM READING CORRECTED FOR OFFSET in Table 7-5 is greater than 100 mV for a STEP ATTENUATOR SETTING of 70 dB, A14R16* should be selected for a DVM reading greater than the reading set in step 16. If the READING CORRECTED FOR OFFSET is less than 100 mV, A14R16* should be selected for DVM reading less than the reading set in step 16.

19. Set output level of signal generator for a digital voltmeter reading of 800 mV plus offset (algebraic sum) in 1 V.
20. Set 8558B 10 dB/DIV - 1 dB/DIV - LIN switch to 10 dB/DIV and adjust A14R2 LOG/LIN adjustment for a digital voltmeter reading of 800 mV plus offset.
21. Repeat step 14 to recheck the log fidelity.
22. Set the 8558B REFERENCE LEVEL dBm control to -50. Set the 10 dB/DIV - 1 dB/DIV - LIN switch to 1 dB/DIV.
002: 0 dBm V
23. Set the step attenuator to 0 dB and set output level of signal generator for a digital voltmeter reading of 700 mV (do not include offset).
24. Set the 8558B REFERENCE LEVEL dBm control to -90 and the step attenuator to 40 dB. Adjust A14RI LOG GAIN adjustment for a digital voltmeter reading of 700 mV.
002: - 40 dBm V

ADJUSTMENTS

7-6. LOG AMPLIFIER LOG AND LINEAR ADJUSTMENT (CHANGE B) (Cont'd)

25. Change REFERENCE LEVEL and step attenuator settings as shown in Table 7-6. Deviation From Reference should not exceed the given limits.

002: REFERENCE LEVEL (dBmV) settings, top to bottom are, 0, -10, -20, -30, -40.

26. Return the TEST-NORM switch on A12 assembly to the NORM position.

Table 7-6. Log Gain Adjustment Limits

Reference Level (dBm)	Step Attenuator Setting (dB)	Deviation From Reference
-50	0	Reference
-60	10	±0.3 DIV ±30 mV
-70	20	±0.3 DIV ±30 mV
-80	30	±0.3 DIV ±30 mV
-90	40	±0.3 DIV ±30 mV

Table 7-7. Replaceable Parts (1 of 4) (CHANGE B)

Reference Designation	HP Part Number	C D	Qty	Description	Mfr. Code	Mfr Part Number
A14	08565-60111	4	1	LOG AMPLIFIER	28480	08565-60111
A14C1	0160-2055	9	59	CAPACITOR-FXD .01UF +80-20% 100VDC CER	28480	0160-2055
A14C2	0160-3459	9	7	CAPACITOR-FXD .02UF +-20% 100VDC CER	28480	0160-3459
A14C3	0160-3459	9		CAPACITOR-FXD .02UF +-20% 100VDC CER	28480	0160-3459
A14C4	0160-3459	9		CAPACITOR-FXD .02UF +-20% 100VDC CER	28480	0160-3459
A14C5	0160-3459	9		CAPACITOR-FXD .02UF +-20% 100VDC CER	28480	0160-3459
A14C6	0160-2055	9		CAPACITOR-FXD .01UF +80-20% 100VDC CER	28480	0160-2055
A14C7	0160-3459	9		CAPACITOR-FXD .02UF +-20% 100VDC CER	28480	0160-3459
A14C8	0160-3459	9		CAPACITOR-FXD .02UF +-20% 100VDC CER	28480	0160-3459
A14C9	0160-2055	9		CAPACITOR-FXD .01UF +80-20% 100VDC CER	28480	0160-2055
A14C10	0160-2055	9		CAPACITOR-FXD .01UF +80-20% 100VDC CER	28480	0160-2055
A14C11	0160-2055	9		CAPACITOR-FXD .01UF +80-20% 100VDC CER	28480	0160-2055
A14C12	0160-2055	9		CAPACITOR-FXD .01UF +80-20% 100VDC CER	28480	0160-2055
A14C13	0160-2055	9		CAPACITOR-FXD .01UF +80-20% 100VDC CER	28480	0160-2055
A14C14	0160-2055	9		CAPACITOR-FXD .01UF +80-20% 100VDC CER	28480	0160-2055
A14C15	0160-2055	9		CAPACITOR-FXD .01UF +80-20% 100VDC CER	28480	0160-2055
A14C16	0160-2055	9		CAPACITOR-FXD .01UF +80-20% 100VDC CER	28480	0160-2055
A14C17	0160-2055	9		CAPACITOR-FXD .01UF +80-20% 100VDC CER	28480	0160-2055
A14C18*	0160-2234	6	1	CAPACITOR-FXD .51PF +- .25PF 500VDC CER	28480	0160-2055
A14C19	0160-2055	9		CAPACITOR-FXD .01UF +80-20% 100VDC CER	28480	0160-2055
A14C20	0160-2236	8		CAPACITOR-FXD 1PF +-25PF 500VDC CER	28480	0160-2236
A14C21	0160-2055	9		CAPACITOR-FXD .01UF +80-20% 100VDC CER	28480	0160-2055
A14C22	0160-2055	9		CAPACITOR-FXD .01UF +80-20% 100VDC CER	28480	0160-2055
A14C23	0160-2055	9		CAPACITOR-FXD .01UF +80-20% 100VDC CER	28480	0160-2055
A14C24	0160-2055	9		CAPACITOR-FXD .01UF +80-20% 100VDC CER	28480	0160-2055
A14C25	0160-2055	9		CAPACITOR-FXD .01UF +80-20% 100VDC CER	28480	0160-2055
A14C26	0160-2055	9		CAPACITOR-FXD .01UF +80-20% 100VDC CER	28480	0160-2055
A14C27	0160-2055	9		CAPACITOR-FXD .01UF +80-20% 100VDC CER	28480	0160-2055
A14C28	0160-0228	6	1	CAPACITOR-FXD 22UF +-10% 15VDC TA	28480	150D226X901582
A14C29	0160-2055	9		CAPACITOR-FXD .01UF +80-20% 100VDC CER	28480	0160-2055
A14C30*	0160-2236	8	5	CAPACITOR-FXD 1PF +-25PF 500VDC CER	28480	0160-2236
A14C31	0160-2055	9		CAPACITOR-FXD .01UF +80-20% 100VDC CER	28480	0160-2055
A14C32	0160-2055	9		CAPACITOR-FXD .01UF +80-20% 100VDC CER	28480	0160-2055
A14C33	0160-2055	9		CAPACITOR-FXD .01UF +80-20% 100VDC CER	28480	0160-2055
A14C34	0160-2055	9		CAPACITOR-FXD .01UF +80-20% 100VDC CER	28480	0160-2055
A14C35	0160-2055	9		CAPACITOR-FXD .01UF +80-20% 100VDC CER	28480	0160-2055
A14C36	0160-2055	9		CAPACITOR-FXD .01UF +80-20% 100VDC CER	28480	0160-2055
A14C37	0160-2055	9		CAPACITOR-FXD .01UF +80-20% 100VDC CER	28480	0160-2055
A14C38	0160-2055	9		CAPACITOR-FXD .01UF +80-20% 100VDC CER	28480	0160-2055
A14C39	0160-2055	9		CAPACITOR-FXD .01UF +80-20% 100VDC CER	28480	0160-2055
A14C40*	0160-2236	8		CAPACITOR-FXD 1PF +-25PF 500VDC CER	28480	0160-2236
A14C41	0160-2055	9		CAPACITOR-FXD .01UF +80-20% 100VDC CER	28480	0160-2055
A14C42	0160-2055	9		CAPACITOR-FXD .01UF +80-20% 100VDC CER	28480	0160-2055
A14C43	0160-2055	9		CAPACITOR-FXD .01UF +80-20% 100VDC CER	28480	0160-2055
A14C44	0160-2055	9		CAPACITOR-FXD .01UF +80-20% 100VDC CER	28480	0160-2055
A14C45				NOT ASSIGNED		
A14C46	0160-2055	9		CAPACITOR-FXD .01UF +80-20% 100VDC CER	28480	0160-2055
A14C47	0160-2055	9		CAPACITOR-FXD .01UF +80-20% 100VDC CER	28480	0160-2055
A14C48	0160-2055	9		CAPACITOR-FXD .01UF +80-20% 100VDC CER	28480	0160-2055
A14C49	0160-2055	9		CAPACITOR-FXD .01UF +80-20% 100VDC CER	28480	0160-2055
A14C50	0160-2055	9		CAPACITOR-FXD .01UF +80-20% 100VDC CER	28480	0160-2055
A14C51	0160-3459	9		CAPACITOR-FXD .02UF +-20% 100VDC CER	28480	0160-3459
A14C52*	0160-2236	8		CAPACITOR-FXD 1PF +-25PF 500VDC CER	28480	0160-2236
A14C53	0160-2055	9		CAPACITOR-FXD .01UF +80-20% 100VDC CER	28480	0160-2055
A14C54	0160-2055	9		CAPACITOR-FXD .01UF +80-20% 100VDC CER	28480	0160-2055
A14C55	0160-2055	9		CAPACITOR-FXD .01UF +80-20% 100VDC CER	28480	0160-2055
A14C56	0160-2055	9		CAPACITOR-FXD .01UF +80-20% 100VDC CER	28480	0160-2055
A14C57*	0160-2256	2		CAPACITOR-FXD 9.1PF +- .2PF 500VDC CER	28480	0160-2256
A14C58	0160-2055	9		CAPACITOR-FXD .01UF +80-20% 100VDC CER	28480	0160-2055
A14C59	0160-2055	9		CAPACITOR-FXD .01UF +80-20% 100VDC CER	28480	0160-2055
A14C60	0160-2055	9		CAPACITOR-FXD .01UF +80-20% 100VDC CER	28480	0160-2055
A14C61	0160-2055	9		CAPACITOR-FXD .01UF +80-20% 100VDC CER	28480	0160-2055
A14C62	0160-0195	2	1	CAPACITOR-FXD 130PF +-5% 300VDC MICA	28480	DM15F131J0300WV1CR
A14C63	0160-2055	9		CAPACITOR-FXD .01UF +80-20% 100VDC CER	28480	0160-2055
A14C64	0160-2308	5	1	CAPACITOR-FXD 36PF +-5% 500VDC MICA	28480	0160-2308
A14C65	0160-2240	4	1	CAPACITOR-FXD 2PF +- .25PF 500VDC CER	28480	0160-2240
A14C66	0160-2055	9		CAPACITOR-FXD .01UF +80-20% 100VDC CER	28480	0160-2055
A14C67	0160-2236	8		CAPACITOR-FXD 1PF +- .25PF 500VDC CER	28480	0160-2236
A14C68	0160-2055	9		CAPACITOR-FXD .01UF +80-20% 100VDC CER	28480	0160-2055
A14C69	0160-2055	9		CAPACITOR-FXD .01UF +80-20% 100VDC CER	28480	0160-2055
A14C70	0160-2055	9		CAPACITOR-FXD .01UF +80-20% 100VDC CER	28480	0160-2055

See introduction to this section for ordering information

*Indicates factory selected value

Table 7-7. Replaceable Parts (2 of 4) (CHANGE B)

Reference Designation	HP Part Number	C D	Qty	Description	Mfr. Code	Mfr Part Number
A14C71	0160-2055	9		CAPACITOR-FXD .01UF +80-20% 100VDC CER	28480	0160-2055
A14C72	0160-2055	9		CAPACITOR-FXD .01UF +80-20, 100VDC CER	28480	0160-2055
A14C73	0160-2055	9		CAPACITOR-FXD .01UF +80-20 100VDC CER	28080	0160-2055
A14C74	0180-2206	4	1	CAPACITOR-FXD 60UF+ -10% 6VDC TA	56289	150D606X9006B2
A14C75	0160-2055	9		CAPACITOR-FXD .01UF +80-20% 100VDC CER	28480	0160-2055
A14C76	0160-2055	9		CAPACITOR-FXD .01UF +80-20% 100VDC CER	28480	0160-2055
A14C77	0160-2055	9		CAPACITOR-FXD .01UF +80-20% 100VDC CE	28480	0160-2055
A14C78	0180-0197	8	5	CAPACITOR-FXD 2.2UF+ -10% 20VDC TA	56280	150D225X9020A2
A14CR1	1901-0040	1	17	DIODE-SWITCHING 30V 50MA 2NS DO-35	28480	1901-0040
A14CR2	1901-0040	1		DIODE-SWITCHING 30V 50MA 2NS DO-35	28480	1901-0040
A14CR3	1901-1085	6	17	DIODE-SCHOTTKY	28480	1901-1085
A14CR4	1901-1085	6		DIODE-SCHOTTKY	28480	1901-1085
A14CR5	1901-0040	1		DIODE-SWITCHING 30V 50MA 2NS DO-35	28480	1901-0040
A14CR6	1901-0040	1		DIODE-SWITCHING 30V 50MA 2NS DO-35	284080	1901-0040
A14CR7	1901-0040	1		DIODE-SWITCHING 30V 50MA 2NS DO-35	28480	1901-0040
A14CR8	1901-1085	6		DIODE-SCHOTTKY	28480	1901-1085
A14CR9	1901-1085	6		DIODE-SCHOTTKY	28480	1901-1085
A14CR10	1901-1085	6		DIODE-SCHOTTKY	28480	1901-1085
A14CR11	1901-1085	6		DIODE-SCHOTTKY	28480	1901-1085
A14CR12	1901-1085	6		DIODE-SCHOTTKY	28480	1901-1085
A14CR13	1901-1085	6		DIODE-SCHOTTKY	28480	1901-1085
A14CR14	1901-0040	8	3	DIODE-SWITCHING 20V 75MA 10NS	28480	1901-0047
A14CR15	1901-1085	6		DIODE-SCHOTTKY	28480	1901-1085
A14CR16	1901-1070	9	2	DIODE-PIN 110V	28480	1901-1010
A14CR17	1901-1085	6		DIODE-SCHOTTKY	28480	1901-1085
A14CR18	1901-1070	9		DIODE-PIN 110V	28480	1901-1070
A14CR19	1901-0040	1		DIODE-SWITCHING 30V 50MA 2NS DO-35	28480	1901-0040
A14CR20	1901-1085	6		DIODE-SCHOTTKY	28480	1901-1085
A14CR21	1901-1085	6		DIODE-SCHOTTKY	28480	1901-1085
A14CR22	1901-1085	6		DIODE-SCHOTTKY	28480	1901-1085
A14CR23	1901-1085	6		DIODE-SCHOTTKY	28480	1901-1085
A14CR24	1901-0040	1		DIODE-SWITCHING 30V 50MA 2NS DO-35	28480	1901-0040
A14CR25	1901-1085	6		DIODE-SCHOTTKY	28480	1901-1085
A14CR26	1901-0047	8		DIODE-SWITCHING 20V 75MA 10NS	28480	1901-0047
A14CR27	1901-1085	6		DIODE-SCHOTTKY	28480	1901-1085
A14CR28	1901-1085	6		DIODE-SCHOTTKY	28480	1901-1085
A14CR29	1901-0047	8		DIODE-SWITCHING 20V 75MA 10NS	28480	1901-0047
A14CR30	1901-0040	1		DIODE-SWITCHING 30V 50MA 2NS DO-35	28480	1901-0040
A14CR31	1901-0040	1		DIODE-SWITCHING 30V 50MA 2NS DO-35	28480	1901-0040
A14CR32	1901-0040	1		DIODE-SWITCHING 30V 50MA 2NS DO-35	28480	1901-0040
A14E1	9170-0029	3	1	CORE-SHIELDING READ	28480	9170-0029
A14L1	9100-1622	7	2	COIL-MLD 24AUH 5% Q=60 .155DX .375L-NOM	28480	9100-1622
A14L2	9100-0105	3	1	COIL-MLD 8.2UH 10% Q=50 .155DX .375LG-NOM	28480	9100-0105
A14L3	9100-1619	2	7	COIL-MLD 6.8UH 10% Q=50 .155DX .375LG-NOM	28480	9100-1619
A14L4	9100-1619	2		COIL-MLD 6.8UH 10% Q=50 .155DX .375LG-NOM	28480	9100-1619
A14L5	9100-	2		COIL-MLD 6.8UH 10% Q=50 .155DX .375LG-NOM	28480	9100-1619
A14L6	9100-1619	2		COIL-MLD 6.8UH 10% Q=50 .155DX .375LG-NOM	28480	9100-1619
A14L7	9100-1619	2		COIL-MLD 6.8UH 10% Q=50 .155DX .375LG-NOM	28480	9100-1619
A14L8	9100-1619	2		COIL-MLD 6.8UH 10% Q=50 .155DX .375LG-NOM	28480	9100-1619
A14L9	9100-1627	2	1	COIL-MLD 39UH 5% Q=60 .155DX.375LG-NOM	28480	9100-1627
A14L10	9100-1629	4	1	COIL-MLD 47UH 5% Q=55 .155DX.375LG-NOM	28480	9100-1629
A14L11	9100-1622	7		COIL-MLD 24UH 5% Q=60 .155DX .375LG-NOM	28480	9100-1622
A14L12	9100-1619	2		COIL-MLD 6.8UH 10% Q=50 .155DX .375LG-NOM	28480	9100-1619
A14L13	9140-0145	1	1	COIL-MLD 8.2UH 10% Q=60 .095DX .25LG-NOM	28480	9140-0145
A14L14	9100-2269	0	0	COIL-MLD 27UH 10% Q=45 .095DX .25LG-NOM	28480	9100-2269
A14Q1	1854-0071	7	3	TRANSISTOR NPN SI PD=300mw FT=200MHZ	28480	1854-0071
A14Q2	1854-0019	3	15	TRANSISTOR NPN SI TO-18 PD=360mw	28480	1854-0019
A14Q3	1854-0019	3		TRANSISTOR NPN SI TO-18 PD=360mw	28480	1854-0019
A14Q4	1854-0019	3		TRANSISTOR NPN SI TO-18 PD=360mw	28480	1854-0019
A14Q5	1854-0019	3		TRANSISTOR NPN SI TO-18 PD=360mw	28480	1854-0019
A14Q6	1854-0019	3		TRANSISTOR NPN SI TO-18 PD=360mw	28480	1854-0019
A14Q7	1854-0019	3		TRANSISTOR NPN SI TO-18 PD=360mw	28480	1854-0019
A14Q8	1854-0019	3		TRANSISTOR NPN SI TO-18 PD=360mw	28480	1854-0019
A14Q9	1854-0019	3		TRANSISTOR NPN SI TO-18 PD=360mw	28480	1854-0019
A14Q10	1854-0019	3		TRANSISTOR NPN SI TO-18 PD=360mw	28480	1854-0019
A14Q11	1854-0019	3		TRANSISTOR NPN SI TO-18 PD=360mw	28480	1854-0019
A14Q12	1854-0019	3		TRANSISTOR NPN SI TO-18 PD=360mw	28480	1854-0019
A14Q13	1854-0019	3		TRANSISTOR NPN SI TO-18 PD=360mw	28480	1854-0019
A14Q14	1854-0019	3		TRANSISTOR NPN SI TO-18 PD=360mw	28480	1854-0019
A14Q15	1854-0019	3		TRANSISTOR NPN SI TO-18 PD=360mw	28480	1854-0019
A14Q16	1853-0020	4	2	TRANSISTOR PNP SI PD=300mw FT=150MHZ	28480	1853-0020
A14Q17	1853-0007	7	4	TRANSISTOR PNP 2N3251 SI TO=18 PD=360mw	04713	2N3251
A14Q18	1853-0345	8	1	TRANSISTOR NPN 2N5179 SI TO=72 PD=1200mw	04713	2N5179
A14Q19	1853-0015	7	1	TRANSISTOR PNP SI PD=200mw FT=500MHZ	28480	1853-0015
A14Q20	1854-0475	5	2	TRANSISTOR-DUAL NPN PD=750mw	28480	185-0475

See introduction to this section for ordering information
 * Indicates factory selected value

Table 7-7. Replaceable Parts (3 of 4) (CHANGE B)

Reference Designation	HP Part Number	C D	Qty	Description	Mfr. Code	Mfr Part Number
A14Q21	1854-0404	0	6	TRANSISTOR NPN SI TO=18 PD=360MW	28480	1854-0404
A14Q22	1853-0020	4		TRANSISTOR PNP SI PD=300mw FT=150MHZ	28480	1854-0020
A14Q23	1854-0071	7		TRANSISTOR NPN SI PD=300mw FT=200MHZ	28480	1854-0071
A14Q24	1854-0071	7		TRANSISTOR NPN SI PD=300mw FT=200MHZ	28480	1854-0071
A14Q25	1854-0039	7	2	TRANSISTOR NPN 2N30538 SI TO=39 PD=1w	01928	2N30538
A14R1	2100-3109	2	2	RESISTOR-TRMR 2K 10% C SIDE-ADJ 17-TRN	02111	43P202
A14R2	2100-3161	6	1	RESISTOR-TRMR 20K 10% C SIDE-ADJ 17-TRN	02111	43P203
A14R3	2100-3109	2		RESISTOR-TRMR 2K 10% C SIDE-ADJ 17-TRN	02111	43P202
A14R4	0757-0442	9	9	RESISTOR 10K 1% .125W F TC=0+-100	24546	C4-1/8-TO-1002-F
A14R5	0757-0279	0		RESISTOR 3.16K 1% .125W F TC=0+-100	24546	C4-1/8-TO-3161-F
A14R6*	0757-0346	2	20	RESISTOR 10 1% .125W F TC=0+-100	24546	C4-1/8-TO-1080-F
A14R7	0757-0442	9		RESISTOR 10K 1% .125W F TC=0+-100	24546	C4-1/8-TO-1002-F
A14R8*	0757-0280	3	9	RESISTOR 1K 1% .125W F TC=0+-100	24546	C4-1/8-TO-1001-F
A14R9	0757-0430	4	9	RESISTOR 6.81K 1% .125W F TC=0+-100	24546	C4-1/8-TO-6811-F
A14R10	0757-0465	6	4	RESISTOR 100K 1% .125W F TC=0+-100	24546	C4-1/8-TO-1003-F
A14R11	0757-0440	7	2	RESISTOR 7.5K 1% .125W F TC=0+-100	24546	C4-1/8-TO-7501-F
A14R12	0698-3157	3	2	RESISTOR 19.6K 1% .125W F TC=0+-100	24546	C4-1/8-TO-1962-F
A14R13	0698-3444	1	12	RESISTOR 316 1% .125W F TC=0+-100	24546	C4-1/8-TO-316R-F
A14R14	0757-0420	3	3	RESISTOR 750 1% .125W F TC=0+-100	24546	C4-1/8-TO-751-F
A14R15	0698-3136	8	1	RESISTOR 17.8K 1% .125W F TC=0+-100	24546	C4-1/8-TO-1782-F
A14R16*	0698-3443	0	1	RESISTOR 287 1% .125W F TC=0+-100	24546	C4-1/8-TO-287R-F
A14R17	0698-3156	2	5	RESISTOR 14.7K 1% .125W F TC=0+-100	24546	C4-1/8-TO-1472-F
A14R18				NOT ASSIGNED		
A14R19	0698-0085	0	2	RESISTOR 2.61K 1% .125W F TC=0+-100	24546	C4-1/8-TO-2611-F
A14R20	0757-0279	0		RESISTOR 13.6K 1% .125W F TC=0+-100	24546	C4-1/8-TO-3161-F
A14R21	0757-0289	2	12	RESISTOR 13.3K 1% .125W F TC=0+-100	19701	MF4C1/8-TO-1332-F
A14R22	0757-0346	2		RESISTOR 10 1% .125W F TC=0+-100	24546	C4-1/8-TO-10R0-F
A14R23	0698-3444	1		RESISTOR 316 1% .125W F TC=0+-100	24546	C4-1/8-TO-316R-F
A14R24	0757-0279	0		RESISTOR 3.16K 1% .125W F TC=0+-100	24546	C4-1/8-TO-3161-F
A14R25	0698-3152	1		RESISTOR 316 1% .125W F TC=0+-100	24546	C4-1/8-TO-316R-F
A14R26	0757-0290	5		RESISTOR 16.9K 1% .125W F TC=0+-100	19701	MF4C1/8-TO-6191-F
A14R27	0757-0346	2		RESISTOR 10 1% .125W F TC=0+-100	24546	C4-1/8-TO-10R0-F
A14R28	0698-3449	6	1	RESISTOR 28.7K 1% .125W F TC=0+-100	24546	C4-1/8-TO-2872-F
A14R29	0757-0199	3	7	RESISTOR 21.5K 1% .125W F TC=0+-100	24546	C4-1/8-TO-2152-F
A14R30	0698-3152	8	2	RESISTOR 3.48K 1% .125W F TC=0+-100	24546	C4-1/8-TO-3481-F
A14R31	0757-0279	0		RESISTOR 3.16K 1% .125W F TC=0+-100	24546	C4-1/8-TO-3161-F
A14R32	0757-0289	2		RESISTOR 13.3K 1% .125W F TC=0+-100	19701	MF4C1/8-TO-1332-F
A14R33	0757-0289	2		RESISTOR 13.3K 1% .125W F TC=0+-100	19701	MF4C1/8-TO-1332-F
A14R34	0698-3154	1		RESISTOR 316 1% .125W F TC=0+-100	24546	C4-1/8-TO-316R-F
A14R35*	0757-0346	2		RESISTOR 10 1% .125W F TC=0+-100	24546	C4-1/8-TO-10R0-F
A14R36	0698-3438	3	2	RESISTOR 147 1% .125W F TC=0+-100	24546	C4-1/8-TO-147R-F
A14R37	0757-0439	4		RESISTOR 6.81K 1% .125W F TC=0+-100	24546	C4-1/8-TO-6811-F
A14R38	0757-0279	0		RESISTOR 3.16K 1% .125W F TC=0+-100	24546	C4-1/8-TO-3161-F
A14R39	0698-3154	0	1	RESISTOR 4.22K 1% .125W F TC=0+-100	24546	C4-1/8-TO-4221-F
A14R40	0757-0280	3		RESISTOR 1K 1% .125W F TC=0+-100	24546	C4-1/8-TO-1001-F
A14R41	0757-0346	2		RESISTOR 10 1% .125W F TC=0+-100	24546	C4-1/8-TO-10R0-F
A14R42	0757-0346	2		RESISTOR 10 1% .125W F TC=0+-100	24546	C4-1/8-TO-10R0-F
A14R43	0757-0289	2		RESISTOR 13.3K 1% .125W F TC=0+-100	19701	MF4C1/8-TO-1332-F
A14R44				NOT ASSIGNED		
A14R45	0757-0439	4		RESISTOR 6.81K 1% .125W F TC=0+-100	24546	C4-1/8-TO-6811-F
A14R46*	0698-0083	8	2	RESISTOR 1.96K 1% .125W F TC=0+-100	24546	C4-1/8-TO-1961-F
A14R47	0757-0279	0		RESISTOR 3.16K 1% .125W F TC=0+-100	24546	C4-1/8-TO-3161-F
A14R48	0757-0289	2		RESISTOR 13.3K 1% .125W F TC=0+-100	19701	MF4C1/8-TO-1332-F
A14R49	0757-0416	7	5	RESISTOR 511 1% .125W F TC=0+-100	24546	C4-1/8-TO-511R-F
A14R50	0698-3444	1		RESISTOR 316 1% .125W F TC=0+-100	24546	C4-1/8-TO-316R-F
A14R51*	0757-0346	2		RESISTOR 10 1% .125W F TC=0+-100	24546	C4-1/8-TO-10R0-F
A14R52	0757-0465	6		RESISTOR 100K 1% .125W F TC=0+-100	24546	C4-1/8-TO-1003-F
A14R53	0698-0083	8		RESISTOR 1.96K 1% .125W F TC=0+-100	24546	C4-1/8-TO-1961-F
A14R54	0757-0280	3		RESISTOR 1K 1% .125W F TC=0+-100	24546	C4-1/8-TO-1001-F
A14R55	0698-3151	7		RESISTOR 2.87K 1% .125W F TC=0+-100	24546	C4-1/8-TO-2871-F
A14R56	0757-0458	7		RESISTOR 51.1K 1% .125W F TC=0+-100	24546	C4-1/8-TO-5112-F
A14R57	0757-0346	2		RESISTOR 10.1K 1% .125W F TC=0+-100	24546	C4-1/8-TO-10R0-F
A14R58	0757-0289	2		RESISTOR 13.3K 1% .125W F TC=0+-100	19701	MF4C1/8-TO-1332-F
A14R59	0757-0442	9		RESISTOR 10K 1% .125W F TC=0+-100	24546	C4-1/8-TO-1002-F
A14R60	0698-3157	3		RESISTOR 19.6K 1% .125W F TC=0+-100	24546	C4-1/8-TO-1962-F
A14R61	0757-0442	9		RESISTOR 10K 1% .125W F TC=0+-100	24546	C4-1/8-TO-1002-F
A14R62	0698-3152	8		RESISTOR 3.48K 1% .125W F TC=0+-100	24546	C4-1/8-TO-3481-F
A14R63	0698-3159	5	1	RESISTOR 2.61K 1% .125W F TC=0+-100	24546	C4-1/8-TO-2612-F
A14R64*	0757-0279	0	14	RESISTOR 3.16K 1% .125W F TC=0+-100	24546	C4-1/8-TO-3161-F
A14R65	0757-0290	5		RESISTOR 6.19K 1% .125W F TC=0+-100	19701	MF4C1/8-TO-6191-F
A14R66	0757-0439	4		RESISTOR 6.81K 1% .125W F TC=0+-100	24546	C4-1/8-TO-6811-F
A14R67	0757-0279	0		RESISTOR 3.16K 1% .125W F TC=0+-100	24546	C4-1/8-TO-3161-F
A14R68	0757-0289	2		RESISTOR 13.3K 1% .125W F TC=0+-100	19701	MF4C1/8-TO-1332-F
A14R69	0757-0440	7		RESISTOR 7.5K 1% .125W F TC=0+-100	24546	C4-1/8-TO-7501-F
A14R70	0757-0463	4	1	RESISTOR 82.5K 1% .125W F TC=0+-100	24546	C4-1/8-TO-8252-F

See introduction to this section for ordering information
 *Indicates factory selected value

Table 7-7. Replaceable Parts (4 of 4) (CHANGE B)

Reference Designation	HP Part Number	C D	Qty	Description	Mfr. Code	Mfr Part Number
A14R71	0698-3444	1		RESISTOR 316 1% .125W F TC=0+-100	24546	C4-1/8-TO-316R-F
A14R72	0757-0290	5		RESISTOR 6.19K 1% .125W F TC=0+-100	19701	MF4C1/8-TO-6191-F
A14R73*	0757-0346	5		RESISTOR 10 1% .125W F TC=0+-100	19701	C4-1/8-TO-10R0-F
A14R74*	0698-3151	1		RESISTOR 2.87K 1% .125W F TC=0+-100	24546	C4-1/8-TO-2871-F
A14R75	0757-0442	5		RESISTOR 10K 1% .125W F TC=0+-100	19701	C4-1/8-TO-1002-F
A14R76	0757-0289	5		RESISTOR 13.3K 1% .125W F TC=0+-100	19701	MF4C1/8-TO-1332-F
A14R77	0757-0280	1		RESISTOR 1K 1% .125W F TC=0+-100	24546	C4-1/8-TO-1001-F
A14R78	0757-0346	1		RESISTOR 10 1% .125W F TC=0+-100	24546	C4-1/8-TO-10R0-F
A14R79	0757-0346	1		RESISTOR 10 1% .125W F TC=0+-100	24546	C4-1/8-TO-10R0-F
A14R80	0757-0439	1		RESISTOR 6.81K 1% .125W F TC=0+-100	24546	C4-1/8-TO-6811-F
A14R81	0757-0403	1		RESISTOR 121 1% .125W F TC=0+-100	24546	C4-1/8-TO-121R-F
A14R82*	0757-0290	5		RESISTOR 6.19K 1% .125W F TC=0+-100	19701	MF4C1/8-TO-6191-F
A14R83	0757-0418	1		RESISTOR 619 1% .125W F TC=0+-100	24546	C4-1/8-TO-619R-F
A14R84	0757-0402	1		RESISTOR 110 1% .125W F TC=0+-100	24546	C4-1/8-TO-111-F
A14R85	0757-0279	1		RESISTOR 3.16 1% .125W F TC=0+-100	24546	C4-1/8-TO-3161-F
A14R86				NOT ASSIGNED		
A14R87	0757-0289	5		RESISTOR 13.3K 1% .125W F TC=0+-100	19701	MF4C1/8-TO-1332-F
A14R88	0757-0416	1		RESISTOR 511 1% .125W F TC=0+-100	24546	C4-1/8-TO-511R-F
A14R89	0757-0346	1		RESISTOR 10 1% .125W F TC=0+-100	24546	C4-1/8-TO-10R0-F
A14R90	0698-3444	1		RESISTOR 316 1% .125W F TC=0+-100	24546	C4-1/8-TO-316R-F
A14R91	0757-0439	1		RESISTOR 6.81K 1% .125W F TC=0+-100	24546	C4-1/8-TO-6811-F
A14R92	0757-0346	1		RESISTOR 10 1% .125W F TC=0+-100	24546	C4-1/8-TO-10R0-F
A14R93	0757-0438	1		RESISTOR 5.11K 1% .125W F TC=0+-100	24546	C4-1/8-TO-5111-F
A14R94	0757-0346	1		RESISTOR 10 1% .125W F TC=0+-100	24546	C4-1/8-TO-10R0-F
A14R95	0757-0289	5		RESISTOR 13.3K 1% .125W F TC=0+-100	19701	MF4C1/8-TO-1332-F
A14R96	0757-0280	1		RESISTOR 1K 1% .125W F TC=0+-100	24546	C4-1/8-TO-1001-F
A14R97	0757-0346	1		RESISTOR 10 1% .125W F TC=0+-100	24546	C4-1/8-TO-10R0-F
A14R98	0757-0346	1		RESISTOR 10 1% .125W F TC=0+-100	24546	C4-1/8-TO-10R0-F
A14R99	0757-0346	1		RESISTOR 10 1% .125W F TC=0+-100	24546	C4-1/8-TO-10R0-F
A14R100	0757-0346	1		RESISTOR 10 1% .125W F TC=0+-100	24546	C4-1/8-TO-10R0-F
A14R101	0757-0439	1		RESISTOR 6.81K 1% .125W F TC=0+-100	24546	C4-1/8-TO-6811-F
A14R102*	0757-0290	5		RESISTOR 6.19K 1% .125W F TC=0+-100	19701	MF4C1/8-TO-6191-F
A14R103	0757-0405	1		RESISTOR 162 1% .125W F TC=0+-100	24546	C4-1/8-TO-162R-F
A14R104	0757-0279	1		RESISTOR 3.16K 1% .125W F TC=0+-100	24546	C4-1/8-TO-3161-F
A14R105	0757-0280	1		RESISTOR 1K 1% .125W F TC=0+-100	24546	C4-1/8-TO-1001-F
A14R106	0757-0289	5		RESISTOR 13.3K 1% .125W F TC=0+-100	19701	MF4C1/8-TO-1332-F
A14R107	0757-0288	5		RESISTOR 9.09K 1% .125W F TC=0+-100	19701	MF4C1/8-TO-9091-F
A14R108	0698-3444	1		RESISTOR 316 1% .125W F TC=0+-100	24546	C4-1/8-TO-316R-F
A14R109	0757-0439	1		RESISTOR 6.81K 1% .125W F TC=0+-100	24546	C4-1/8-TO-6811-F
A14R110	0757-0346	1		RESISTOR 10 1% .125W F TC=0+-100	24546	C4-1/8-TO-10R0-F
A14R111	0698-3158	1		RESISTOR 23.7K 1% .125W F TC=0+-100	24546	C4-1/8-TO-2372-F
A14R112	0698-3160	1		RESISTOR 31.6K 1% .125W F TC=0+-100	24546	C4-1/8-TO-3162-F
A14R113	0698-3160	1		RESISTOR 31.6K 1% .125W F TC=0+-100	24546	C4-1/8-TO-3162-F
A14R114	0698-3160	1		RESISTOR 31.6K 1% .125W F TC=0+-100	24546	C4-1/8-TO-3162-F
A14R115	0757-0346	1		RESISTOR 10 1% .125W F TC=0+-100	24546	C4-1/8-TO-10R0-F
A14R116	0757-0289	5		RESISTOR 13.3K 1% .125W F TC=0+-100	19701	MF4C1/8-TO-1332-F
A14R117	0698-0085	1		RESISTOR 2.61K 1% .125W F TC=0+-100	24546	C4-1/8-TO-2611-F
A14R118	0757-0439	1		RESISTOR 6.81K 1% .125W F TC=0+-100	24546	C4-1/8-TO-6811-F
A14R119*	0757-0290	5		RESISTOR 6.19K 1% .125W F TC=0+-100	19701	MF4C1/8-TO-6191-F
A14R120	0757-0279	1		RESISTOR 3.16K 1% .125W F TC=0+-100	24546	C4-1/8-TO-3161-F
A14R121	0698-0348	1		RESISTOR 147 1% .125W F TC=0+-100	24546	C4-1/8-TO-147R-F
A14R122	0757-0447	1		RESISTOR 16.2K 1% .125W F TC=0+-100	24546	C4-1/8-TO-1622-F
A14R123	0757-0447	1		RESISTOR 16.2K 1% .125W F TC=0+-100	24546	C4-1/8-TO-1622-F
A14R124	0757-0441	1		RESISTOR 8.25K 1% .125W F TC=0+-100	24546	C4-1/8-TO-8251-F
A14R125	0698-3260	9	2	RESISTOR 464K 1% .125W F TC=0+-100	28480	0698-3260
A14R126	0757-0442	1		RESISTOR 10K 1% .125W F TC=0+-100	24546	C4-1/8-TO-1002-F
A14R127	0757-0421	1		RESISTOR 825 1% .125W F TC=0+-100	24546	C4-1/8-TO-825R-F
A14R128	0757-0290	5		RESISTOR 6.19K 1% .125W F TC=0+-100	19701	MF4C1/8-TO-6191-F
A14R129	0757-0290	5		RESISTOR 6.19K 1% .125W F TC=0+-100	19701	MF4C1/8-TO-6191-F
A14R130*	0757-0467	1		RESISTOR 121K 1% .125W F TC=0+-100	24546	C4-1/8-TO-1213-F
A14U1	1826-0092	3	2	OP AMP GP DUAL TO-99	28480	1826-0092
A14VR1	1902-0041	4	1	DIODE-ZNR 5.11V 5% DO-7 PD=.4W TC=-.009%	28480	1902-0041
A14VR2	1902-0048	1	1	DIODE-ZNR 6.81V 5% DO-7 PD=.4W TC=+.043%	28480	1902-0048
A14VR3	1902-0579	3	1	DIODE-ZNR 5.11V 5% DO-15 PD=1W TC=-.009%	28480	1902-0579

See introduction to this section for ordering information
 *Indicates factory selected value

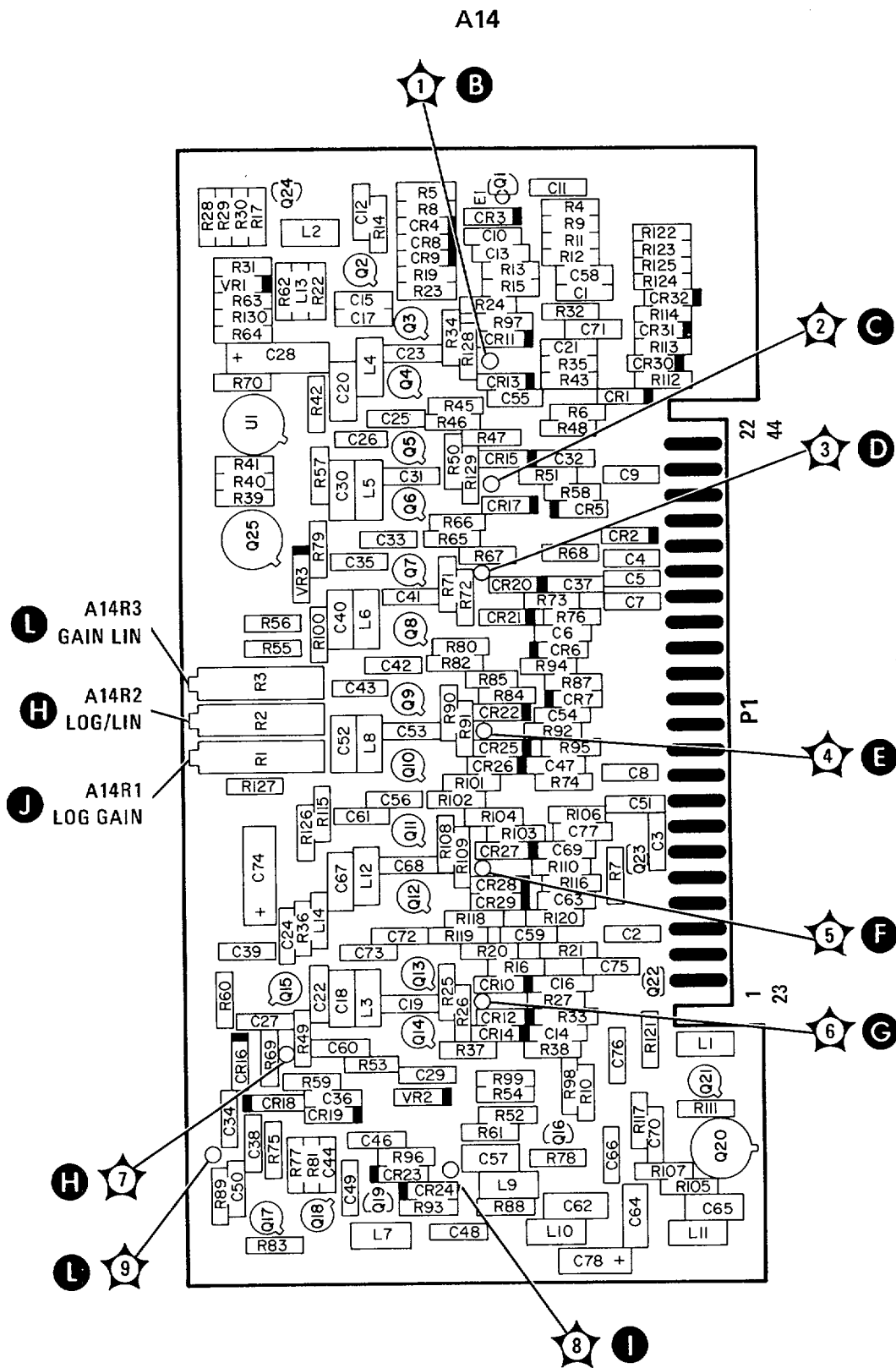

Figure 7-5. A14 Log Amplifier, Component and Test Point Locations (CHANGE B)

THIS PAGE MISSING NOT AVAILABLE FOR DIGITIZATION.

PAGES
7-25 through 7-26

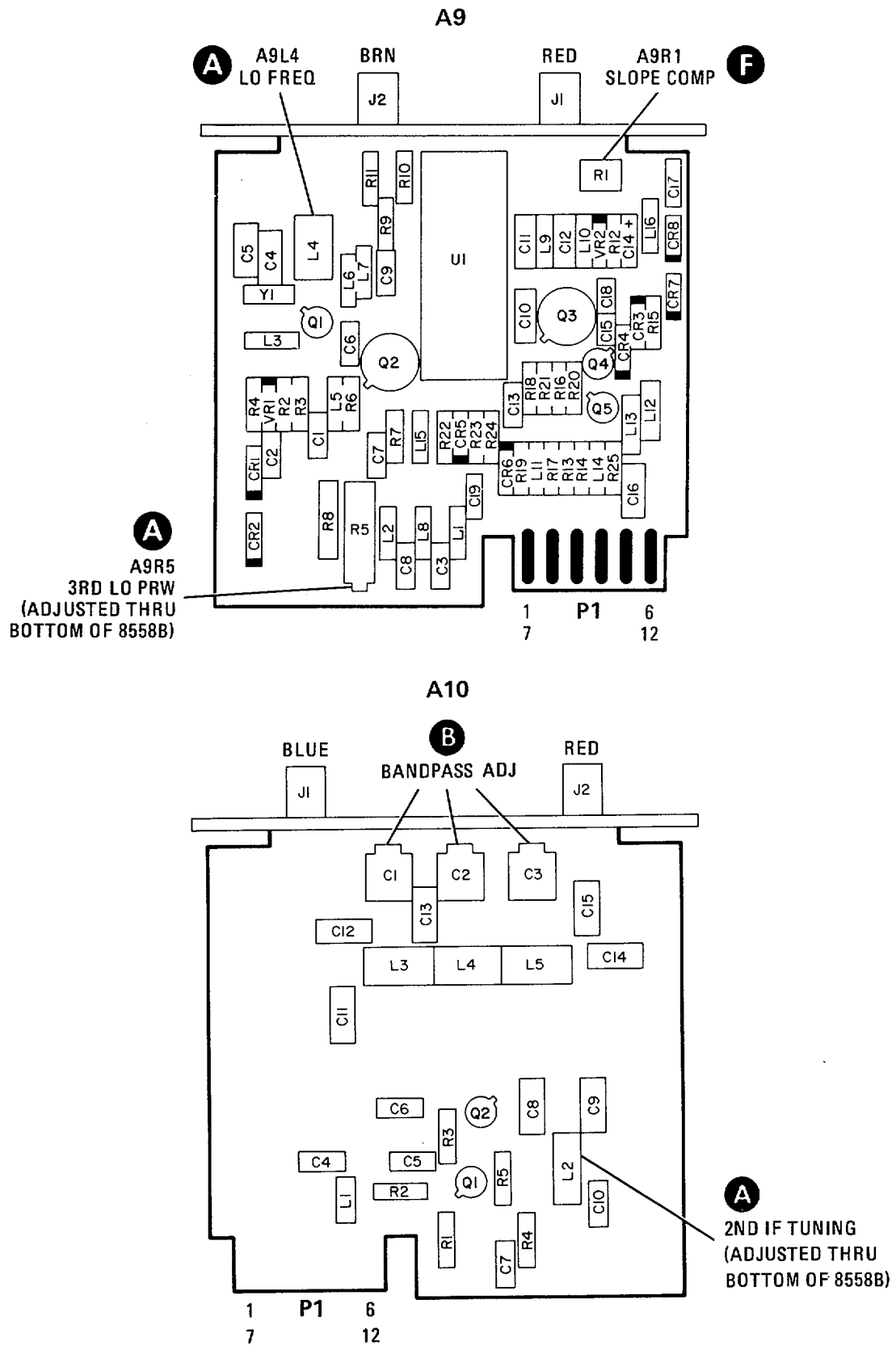

Figure 7-7. A9 Third Converter and A10 Second IF, Component Locations (CHANGE C)

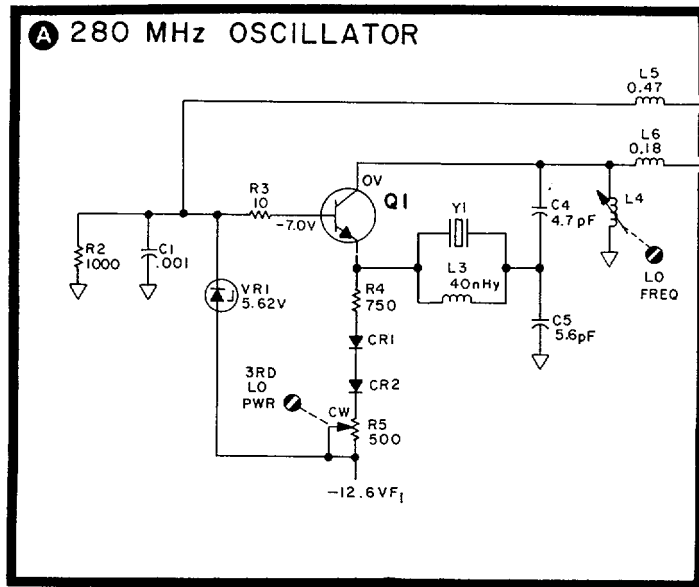

Figure 7-8. P/O A9 Third Converter and A10 Second IF Schematic Diagram (CHANGE C)

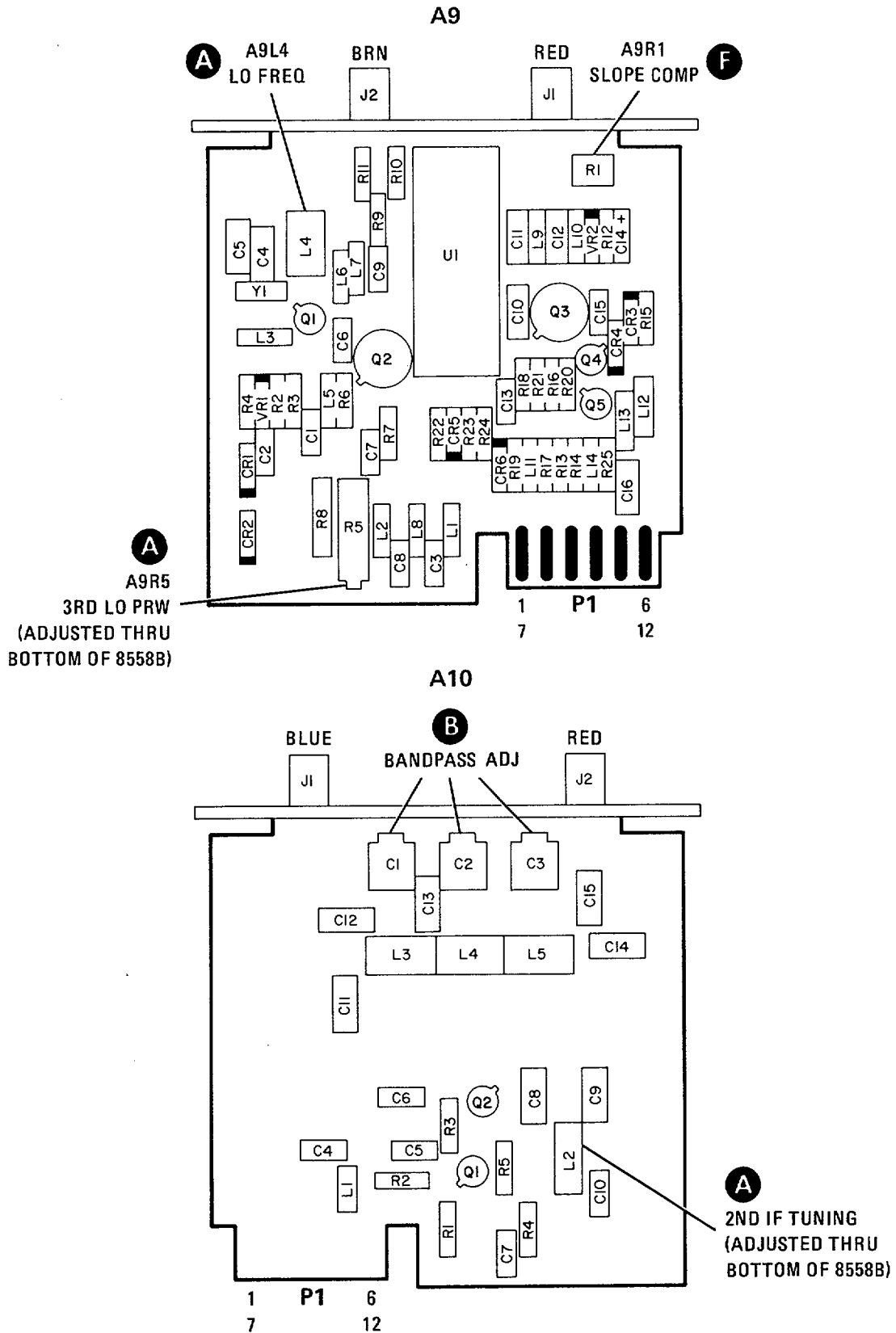

Figure 7-9. A9 Third Converter and A10 Second IF, Component Locations (CHANGE F)

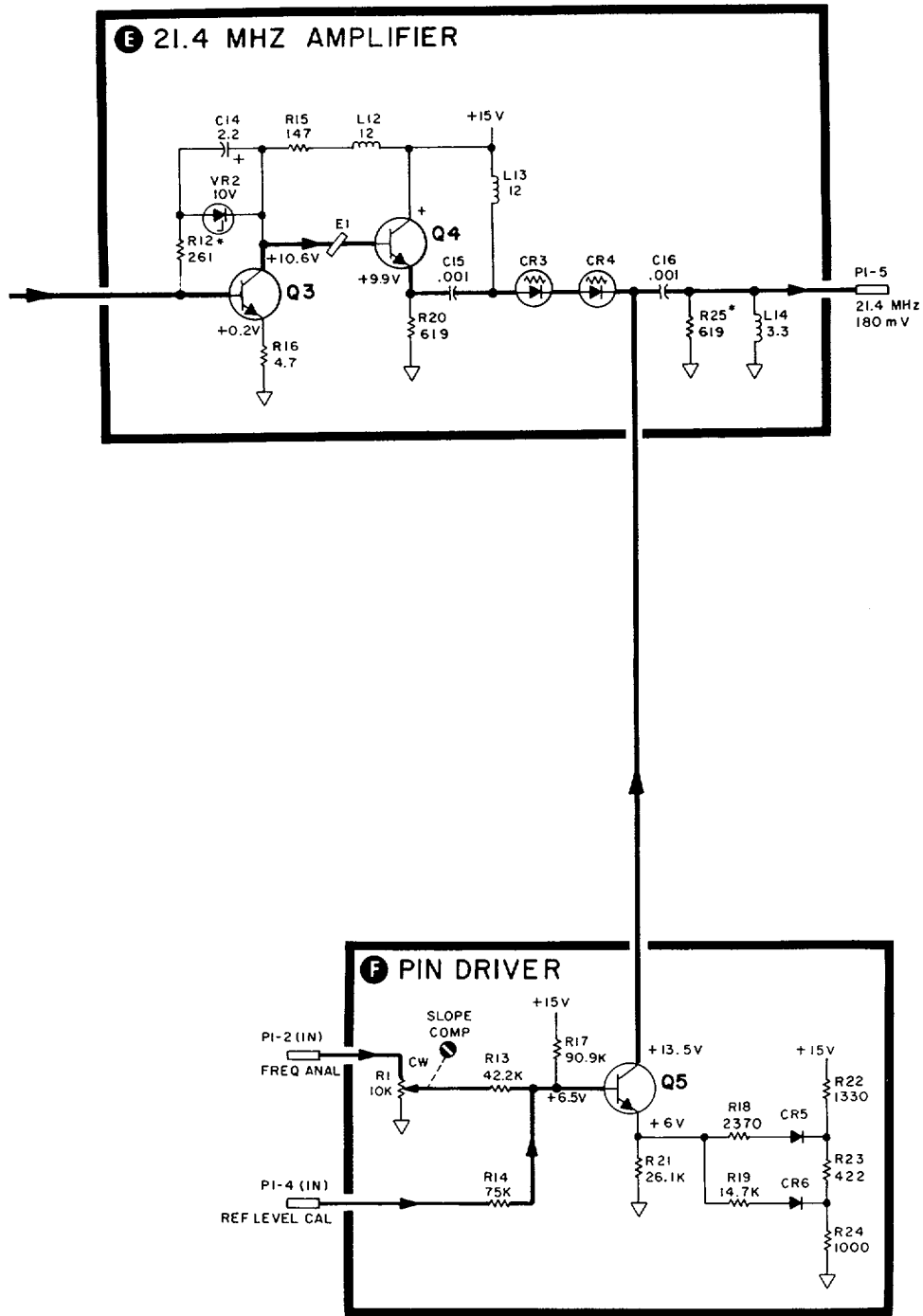

Figure 7-10. P/O A9 Third Converter and A10 Second IF Schematic Diagram (CHANGE F)

SECTION VIII. SERVICE

8-1. INTRODUCTION

8-2. This section provides instructions for troubleshooting and repairing the HP Model 8558B Spectrum Analyzer. It includes general servicing hints and information, block diagrams of the instrument, circuit descriptions, parts identification illustrations, and schematic diagrams.

WARNING

To troubleshoot and repair this instrument, you must remove it from the display mainframe and reconnect it to the mainframe through an extender cable. Operating the spectrum analyzer outside the mainframe in this manner exposes high voltage points in the instrument which might, if contacted, cause personal injury. Maintenance and repair of this instrument should, therefore, be performed only by a skilled person who knows the hazards involved.

8-3. SERVICE INFORMATION INDEX

8-4. Table 8-1 lists specific kinds of information about the spectrum analyzer main assemblies, and indicates where the information is located. The service information for each assembly normally includes a description of the assembly circuits, a diagram showing the locations of the assembly components, and a schematic of the assembly circuits. These packages of assembly information are arranged in assembly number order with the circuit descriptions and component locations diagram preceding the assembly schematic. The assembly numbers are printed in large, bold-faced, alpha-numeric characters (e.g., A4) in the lower right-hand corner of each schematic diagram.

8-5. SCHEMATIC SYMBOLS, TERMINOLOGY, AND VOLTAGE LEVELS

8-6. Symbols and terminology used on the schematic diagrams are explained in Figure 8-1.

Test conditions for the signal and dc voltage levels shown on the block and schematic diagrams are provided in Figure 8-2.

8-7. TEST EQUIPMENT

8-8. Test instruments and accessories used to maintain the spectrum analyzer are listed in Table 1-4. If the listed instrument is not available, another instrument that meets the required minimum specifications may be substituted.

8-9. TROUBLESHOOTING

8-10. General

8-11. Troubleshooting to the assembly level is accomplished by referring to the overall and troubleshooting block diagrams, and by checking for the voltages given for the various system test points. Once the problem is isolated to a particular assembly, the circuit description and schematic diagram for the suspect assembly are used to locate the faulty component.

8-12. Before pursuing any troubleshooting in the spectrum analyzer, you should first make sure the problem is not in the display mainframe, or is not caused by a faulty connection between the spectrum analyzer and the display mainframe.

8-13. Troubleshooting Hints

NOTE

When a part is replaced, an adjustment of the affected circuitry is usually required. For adjustment procedures, refer to Section V.

8-14. Residual FM. The troubleshooting procedure provided in Table 8-2 can usually isolate the cause of residual FM to a particular circuit or circuit component. Figure 8-3 shows how certain components affect FM in these procedures. Note that the zener diode causes peaks which are sharp and extreme compared to the IC peaks. A leaky

Table 8-1. Service Information Index (1 of 2)

Subject	Location
General Troubleshooting Troubleshooting Hints Residual FM Sideband Noise Spurious Responses Baseline Step Troubleshooting Block Diagram	Paragraph 8-10 Paragraph 8-14 Paragraph 8-15 Paragraph 8-16 Paragraph 8-17 Figure 8-6
General Principles of Operation Simplified Block Diagram	Paragraph 8-18 Figure 8-5
DPM Driver Assembly A1A2 Schematic (includes display) Component Locations Circuit Description	Figure 8-11 Figure 8-10 Precedes Figure 8-1
Front Switch Assembly A2 Schematic Board Assembly A2A1 Component Locations Disassembly and Repair Procedures	Figure 8-13 Figure 8-12 Follows Figure 8-47
Input Attenuator Assembly A3 Schematic Description	Figure 8-14 Figure 8-18 Precedes Figure 8-18
First Converter Assembly A4 Schematic Component Locations Circuit Description	Figure 8-18 Figure 8-16 Precedes Figure 8-18
Second Converter Assembly A5 Schematic Component Locations Circuit Description	Figure 8-18 Figure 8-17 Precedes Figure 8-18
Frequency Control Assembly A7 Schematic Component Locations Circuit Description	Figure 8-20 Figure 8-19 Precedes Figure 8-20
Sweep Generator Assembly A8 Schematic Component Locations Circuit Description	Figure 8-23 Figure 8-22 Precedes Figure 8-23
Third Converter Assembly A9 Schematic Component Locations Circuit Description	Figure 8-26 Figure 8-25 Precedes Figure 8-26

Table 8-1. Service Information Index (2 of 2)

Subject	Location
Second IF Assembly A10 Schematic Component Locations Circuit Description	Figure 8-26 Figure 8-25 Follows Figure 8-23
Bandwidth Filter No. 1 Assembly A11 Schematic Component Locations Circuit Description	Figure 8-30 Figure 8-29 Precedes Figure 8-30
Step Gain Assembly A12 Schematic Component Locations Circuit Description	Figure 8-33 Figure 8-32 Precedes Figure 8-33
Bandwidth Filter No. 2 Assembly A13 Schematic Component Locations Circuit Description	Figure 8-35 Figure 8-34 Precedes Figure 8-35
Log Amplifier Assembly A14 Schematic Component Locations Circuit Description	Figure 8-38 Figure 8-37 Precedes Figure 8-38
Vertical Driver and Blanking Assembly A15 Schematic Component Locations Circuit Description	Figure 8-42 Figure 8-41 Precedes Figure 8-42
Motherboard Assembly A16 Schematic Component Locations	Figure 8-44 Figure 8-43
Inverter Assembly A17 Schematic Component Locations Circuit Description	Figure 8-46 Figure 8-45 Precedes Figure 8-46
Major Assemblies, Location of	Figure 8-47

electrolytic capacitor (not shown) usually causes the displayed signal to step down and remain at the same level for several divisions before stepping up to a new level.

8-15. Sideband Noise. Sideband noise is usually caused by YIG Oscillator Assembly A6.

8-16. Spurious Responses. Spurious responses are usually caused by loose RF connections. Check all the RF connections.

8-17. Baseline Step. If the left side of the baseline lifts to the signal peak level, the trouble is A7Q17; a lift of the right side of the baseline is caused by A7Q18 (see Figure 8-4).

8-18. GENERAL PRINCIPLES OF OPERATION

8-19. A simplified block diagram of the HP 8558B Spectrum Analyzer is shown in Figure 8-5. The HP 8558B is basically a superheterodyne receiver with a YIG (Yttrium-Iron-Garnet) tuned oscillator for the first LO (local oscillator). The first LO is the only LO that is swept. The sweep width is determined by the sweep attenuator (part of A8) which attenuates the ramp driving the LO. This ramp is produced by the sweep generator on A8. The ramp also drives the horizontal sweep of

the CRT, and is available at a rear panel BNC connector to synchronize other instruments, such as X-Y recorders, with the analyzer.

8-20. The RF input to the spectrum analyzer passes through an attenuator network on assembly A3 which is controlled by the front panel INPUT ATTEN dB control. This control is used to set the input signal level as required for a wide dynamic range. From the attenuator, the signal goes to first converter assembly A4. Here it is mixed with a 2050 to 3550 MHz output from YIG oscillator assembly A6. The lower sideband, 2050 MHz, of the resulting signal is passed by a 2050 MHz IF amplifier immediately following the first converter circuit. It then enters second converter assembly A5 where it is mixed with a fixed 1748.6 MHz signal from a fixed-cavity local oscillator. This produces a 301.4 MHz IF signal which is amplified and fed to third converter assembly A9. This time, the signal is mixed with a 280 MHz signal from a SAWR (surface acoustic wave resonator) oscillator, resulting in a 21.4 MHz IF signal. The final 21.4 MHz signal is amplified and detected, then filtered by low pass video filter A2 before it is applied to the vertical deflection amplifier of the CRT. The vertical deflection seen on the CRT corresponds to the RF input signal amplitude. The 280 MHz signal from the SAWR oscillator is fed out of the front panel for use as a -30 dBm calibration reference.

8-21. Circuit descriptions for each assembly precede the assembly schematic diagram.

SYMBOLS USED IN SCHEMATICS AND BLOCK DIAGRAMS

BASIC COMPONENT SYMBOLS

	<p>Variable Resistor: Clockwise rotation of shaft moves wiper towards end of resistor marked CW.</p>		<p>Light-emitting diode</p>
	<p>Electrolytic capacitor</p>		<p>Transistor, PNP</p>
	<p>Variable capacitor</p>		<p>Transistor, NPN</p>
	<p>Slide, toggle, or rocker switch</p>		<p>MOS-FET, N-Channel</p>
	<p>Ferrite bead (prevents high frequency parasitic oscillations)</p>		<p>Surface Acoustic Wave Resonator (SAWR)</p>
	<p>Pushbutton switch</p>	<p>*</p>	<p>Indicates a factory-select component</p>
	<p>Relay</p>		<p>Indicates shielding conductor for cables</p>
	<p>Crystal</p>		<p>Indicates a plug-in connection</p>
	<p>Speaker</p>		<p>Indicates a soldered or mechanical connection</p>
	<p>Breakdown (zener) diode</p>		<p>Indicates a single pin of a PC board edge connector</p>
	<p>Schottky diode</p>		

Figure 8-1. Symbols Used in Schematics and Block Diagrams (1 of 4)

SYMBOLS USED IN SCHEMATICS AND BLOCK DIAGRAMS

BASIC COMPONENT SYMBOLS

	Connection symbol indicating a Jack (except for PC board edge connectors)		Indicates wire or cable color code. Color code same as resistor color code. First number indicates base color, second and third numbers indicate colored stripes.
	Connection symbol indicating a Plug (except for PC board edge connectors)		Earth ground
	Test Point: Terminal provided for test probe.		Instrument chassis ground. May be accompanied by a number or letter to specify a particular ground.
	Measurement Point: Used to indicate a convenient point for measurement. No terminal provided for test probe.		Screwdriver adjustment
			Front-panel control

COMMONLY USED ASSEMBLY AND CIRCUIT SYMBOLS

	Oscillator		Mixer
	Operational amplifier		Inverter, buffer

Figure 8-1. Symbols Used in Schematics and Block Diagrams (2 of 4)

SYMBOLS USED IN SCHEMATIC AND BLOCK DIAGRAMS

BASIC LOGIC SYMBOLS

Distinctive-Shape Symbols

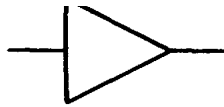

AMPLIFIER/BUFFER

Output is active when input is active.

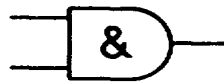

AND FUNCTION

Output is active only when all inputs are active.

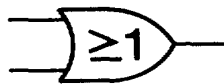

OR FUNCTION

Output is active when one or more inputs are active.

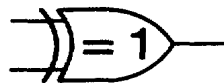

EXCLUSIVE-OR FUNCTION

Output is active when only one input is active.

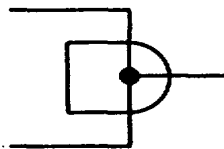

WIRED AND FUNCTION

Two or more elements are joined together to achieve the effect of an AND function.

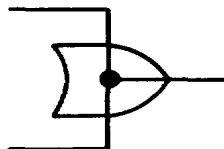

WIRED OR FUNCTION

Two or more elements are joined together to achieve the effect of an OR function.

Figure 8-1. Symbols Used in Schematics and Block Diagrams (3 of 4)

SYMBOLS USED IN SCHEMATIC AND BLOCK DIAGRAMS

BASIC LOGIC SYMBOLS

Indicator Symbols (positive logic assumed)

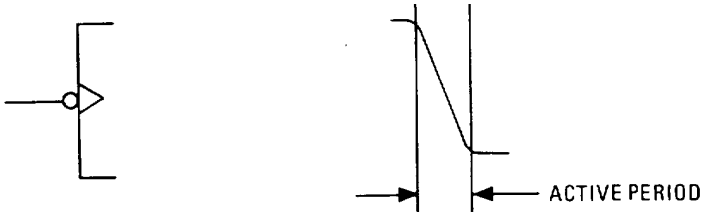

Input is active only on the negative-going transition.

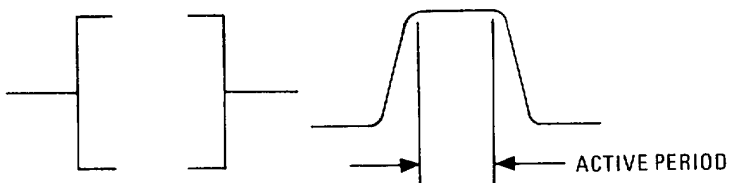

ACTIVE-HIGH inputs and outputs are indicated by the absence of the negation symbol, O.

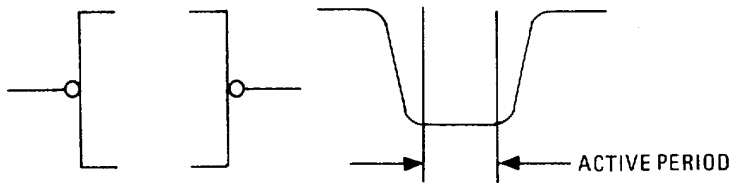

ACTIVE-LOW inputs and outputs are indicated by the presence of the negation symbol, O.

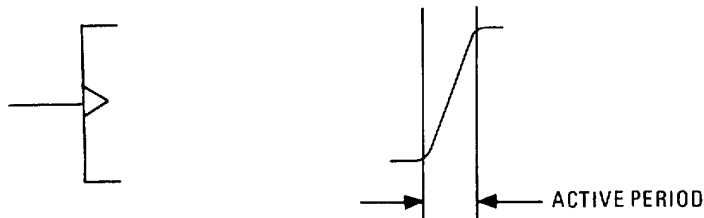

EDGE-TRIGGERED (dynamic) inputs are indicated by the presence of the dynamic input symbol. Input is active only on the positive-going transition.

Figure 8-1. Symbols Used in Schematics and Block Diagrams (4 of 4)

Nominal power levels, voltages, and waveforms shown on schematic diagrams were measured using the test setup shown below. Note that signal characteristics shown on schematic diagrams are provided as a troubleshooting aid only. They should not be used for making instrument adjustments.

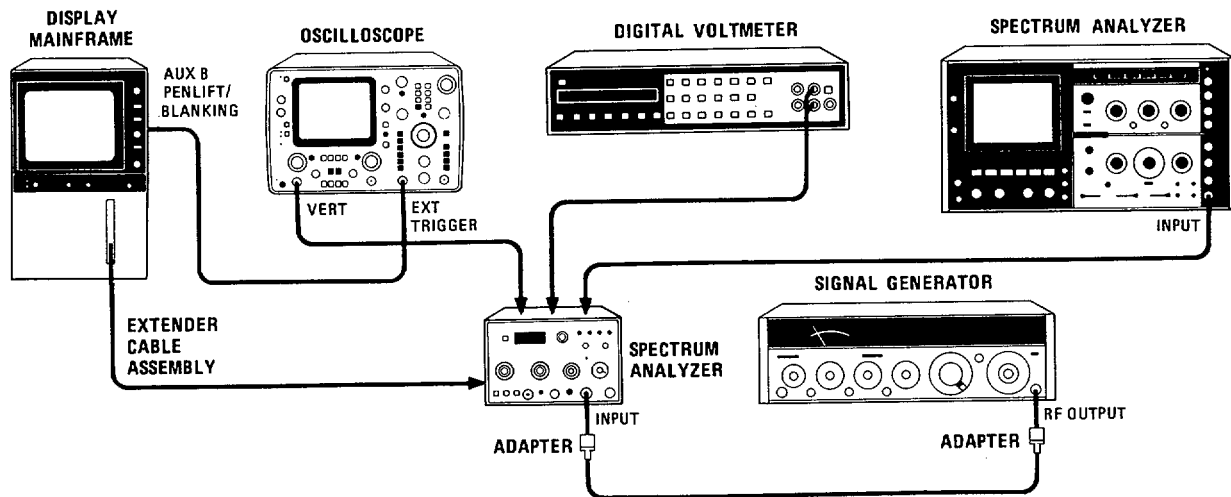

EQUIPMENT:

Oscilloscope(with 10:1 probe)	HP 1741A
Spectrum Analyzer.....	HP 141T/8552B/8555A
Digital Voltmeter	HP 3455A
Signal Generator	HP 8640B
Extender Cable Assembly.....	HP 5060-0303
Adapter, Type N to BNC (2 required).....	HP 1250-0780

Figure 8-2. Conditions for Schematic Diagram Measurements (1 of 2)

PROCEDURE:

1. Set HP 8558B Spectrum Analyzer controls as follows:

START-CENTER	CENTER
TUNING	280 MHz
FREQ SPAN/DIV	1 MHz
RESOLUTION BW	300 kHz
INPUT ATTEN	0 dB
REFERENCE LEVEL.....	-10 dBm
<i>Option 002: +40 dBm V</i>	
REFERENCE LEVEL FINE.....	0
Amplitude Scale.....	10 dB/DIV
SWEEP TIME/DIV.....	AUTO
SWEEP TRIGGER	FREE RUN
VIDEO FILTER	OFF
BASELINE CLIPPER.....	OFF
BL CLIP	OFF

2. Connect equipment as shown. Set signal generator for a 280 MHz, -10 dBm output signal. Center the signal on the display.
3. Using board extenders when necessary, check voltages and waveforms indicated on schematic diagrams. Trigger oscilloscope on negative transition of AUX B PENLIFT/BLANKING signal from rear of display mainframe.
4. To measure RF power levels, set RESOLUTION BW control to 3 MHz and FREQ SPAN/DIV to 0 (zero span). The first LO is not swept in zero span, allowing signal levels to be checked with a second spectrum analyzer (use adapter cables as necessary). DO NOT use a power meter (harmonics and LO signals will contribute to give erroneous levels).

Figure 8-2. Conditions for Schematic Diagram Measurements (2 of 2)

Table 8-2. Residual FM Troubleshooting Procedure (1 of 2)

Troubleshooting Step	Probable FM Source
1. Set 8558B controls as follows: INPUT ATTEN.....0 dB REF LEVEL.....-20 (Option 002: +30 dBm V) FREQ SPAN/DIV.....2 MHz RESOLUTION BW1 MHz SWEEP TIME/DIV.....AUTO SWEEP TRIGGER.....FREE RUN AMPLITUDE SCALELIN VIDEO FILTER.....OFF	
2. Tune LO feedthrough to the left edge of CRT display and make sure a double lobe (Figure 8-3d) does not occur.	Main Coil Filter A7Q4 and associated circuitry.
3. Connect CAL OUTPUT to spectrum analyzer input. Center 280 MHz signal on CRT and adjust REF LEVEL FINE for a top-of-screen signal.	
4. Step FREQ SPAN/DIV from 2 MHz to 1 MHz. Frequency shift should be less than one major division.	Main Coil Filter A7Q4 and associated circuitry.
5. Use FREQUENCY CAL pushbutton to remove YIG hysteresis, then center 280 MHz signal on CRT. Repeated operations should shift signal less than one major division.	Calibrate single shot A7Q21-23. Proceed to step 11.
6. Second LO frequency should be stable and not vary more than 200 kHz (check at A5J3).	ASCR1 or A5Q1
7. Check the voltages at A7TP6 and A7TP7 for correct level and stability. A7TP6 ≈ +6V A7TP7 ≈ +14.5V	A7VR2 A7VR1
8. Select a 10 kHz RESOLUTION BW and tune the spectrum analyzer so the 280 MHz signal skirt crosses the center frequency graticule line between the fourth and seventh horizontal graticule lines. Switch to zero (0) span and select a .1 SEC/DIV sweep time. Peak-to-peak variations of the trace should not exceed one major vertical division for each major horizontal division.	
9. Try FM check (step 8) with TUNING potentiometer in several different positions. (Tune slightly off frequency with COARSE TUNING control and adjust FINE TUNING control for proper display.)	TUNING potentiometer

Table 8-2. Residual FM Troubleshooting Procedure (2 of 2)

Troubleshooting Step	Probable FM Source
10. Disconnect one end of A7C13 and repeat step 8. Reconnect A7C13, disconnect one end of A7C4, and again repeat step 8.	A7C13 or A7C14
11. Remove A7CR2 and A7Q22. If FM is still present, remove A7Q21 and A7Q23.	Calibrate single shot circuit on Frequency Control Assy A7.
12. Remove A7R55 and repeat step 8.	YIG FM coil driver circuit on Frequency Control Assy A7. Probably A7U1.
13. Disconnect one end of A7VR3 or A7CR9 and repeat step 8.	A7VR3 or A7CR9
14. Ground A7TP1 and repeat step 8.	YIG main coil gate on Frequency Control Assy A7.
15. If residual FM is still present, the problem is in the YIG main coil drivers on Frequency Control Assembly A7. Refer to the Frequency Control Assembly schematic diagram for further troubleshooting.	

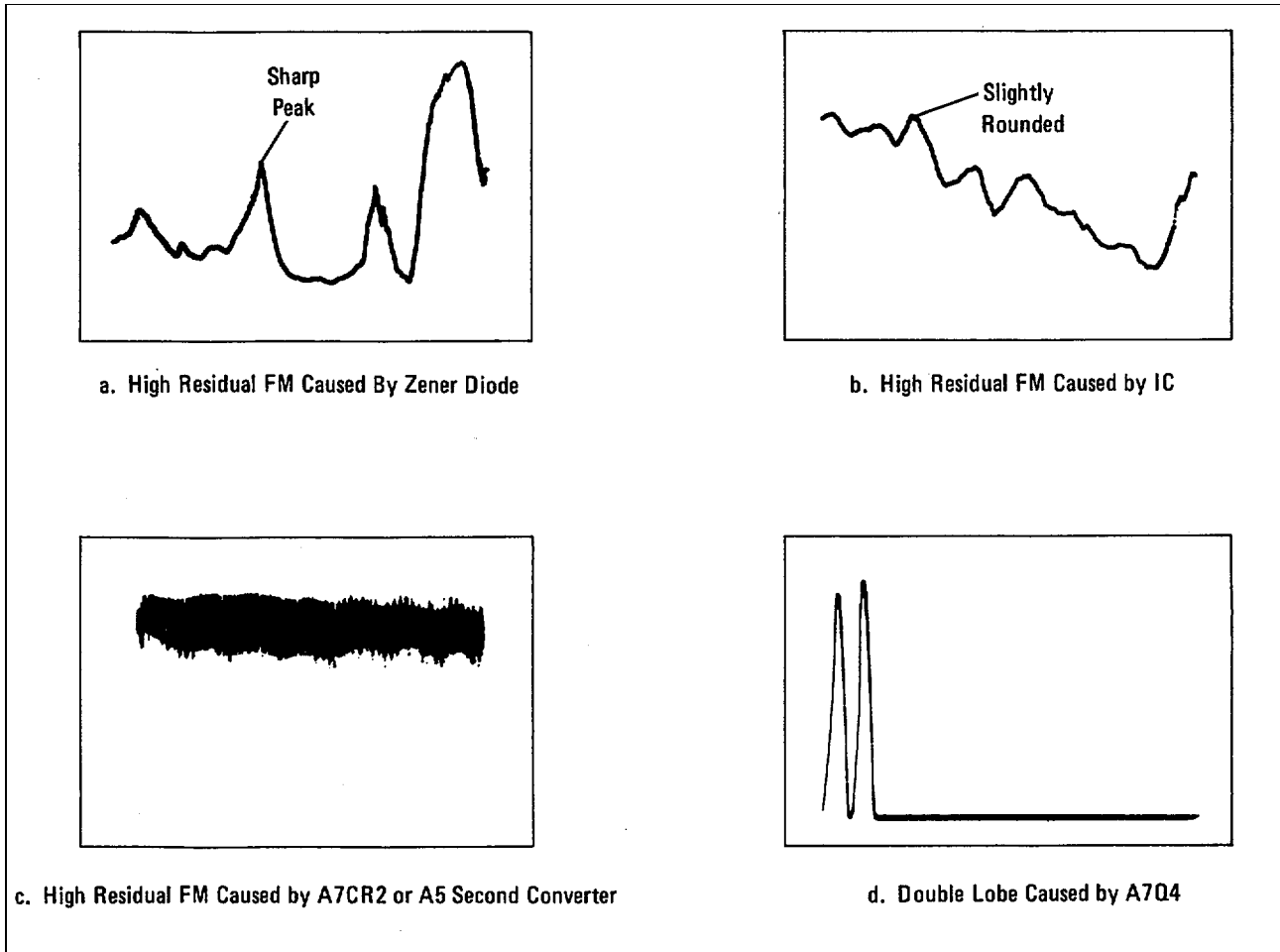

Figure 8-3. CRT Displays for Residual FM Troubleshooting

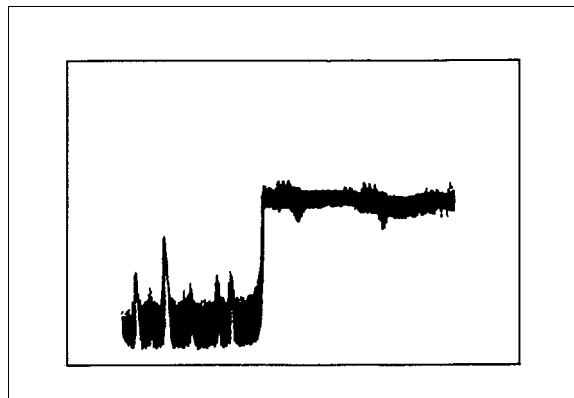

Figure 8-4. Baseline Step Caused by Failure of A7Q18

THIS PAGE MISSING NOT AVAILABLE FOR DIGITIZATION.

PAGES
8-15 through 8-18

A1A2 DPM DRIVER ASSEMBLY CIRCUIT DESCRIPTION

The DPM circuit is a dc voltmeter that measures a tuning voltage from Frequency Control Assembly A7, and converts it to a front-panel frequency readout.

The DPM Driver is divided into three parts:

1. The Analog-to-Digital Converter.
2. The Segment Driver.
3. The Digit Driver.

Analog-to-Digital Converter

The Analog-to-Digital converter comprises an MOS LSI device, A1A2U1, and associated circuitry. A1A2U1 compares the input voltage (MTR V) on pin 3 with a reference voltage (V REF) on pin 2 and outputs the measured voltage in a binary-coded decimal (BCD) format. The BCD data is multiplexed out of A1A2U1, one decimal digit (four bits) at a time on pins 20 through 23. DS1 through DS4 (pins 16 through 19) are the enable lines for A2DS1 (MSD) through A2DS4 (LSD). A1A2R2, A1A2R3, and A1A2R4 form an adjustable voltage divider which divides the 6.2 volts from A16VRI down to approximately 2.0V for the reference voltage (V REF) at pin 2 of A1A2U1.

Segment Drive

A1A2U3 converts the BCD data to seven-segment data for the displays and provides a test function which lights all the segments of all the displays when pin 3 (TP2) is jumpered to ground. A1A2Q3 switches the decimal point LED on for frequencies below 198.6 MHz. (The voltage, MTR V, is multiplied by 10 on the Frequency Control Assembly.) A1A2Q4 allows the 'g' segment line of A2DS1 to go high when the input voltage (MTR V) is less than zero. This causes a minus sign (-) to be displayed.

Digit Driver

The digits are enabled one at a time, sequentially through digit driver A1A2U2. Each digit display is in turn enabled for 300 microseconds until a 250 millisecond period has passed. This is the length of time A1A2U1 requires to make a new voltage measurement. After 250 milliseconds, the new data is put out on pins 20 through 23 of A1A2U1 and the cycle repeats. (See Figures 8-8 and 8-9.)

Display

The digit displays, A2DS1 through A2DS4, are of the common-cathode type. When the digit enable line (cathode) is low and a segment line is high, that segment is turned on. Although only one digit display is enabled at a time, the enable rate is fast enough to prevent visible display flicker.

Troubleshooting

To check the digit displays, jumper A1A2TP2 (LT) to ground. All segments of all four numeric displays (A2DS1 through A2DS4) should light. To troubleshoot DPM Driver A1A2, check for proper clock and outputs at A1A2U1 (see Figures 8-7, 8-8, and 8-9 and Table 8-3).

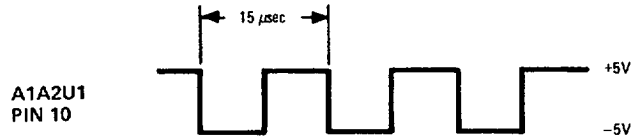

Figure 8-7. A1A2U1 Clock

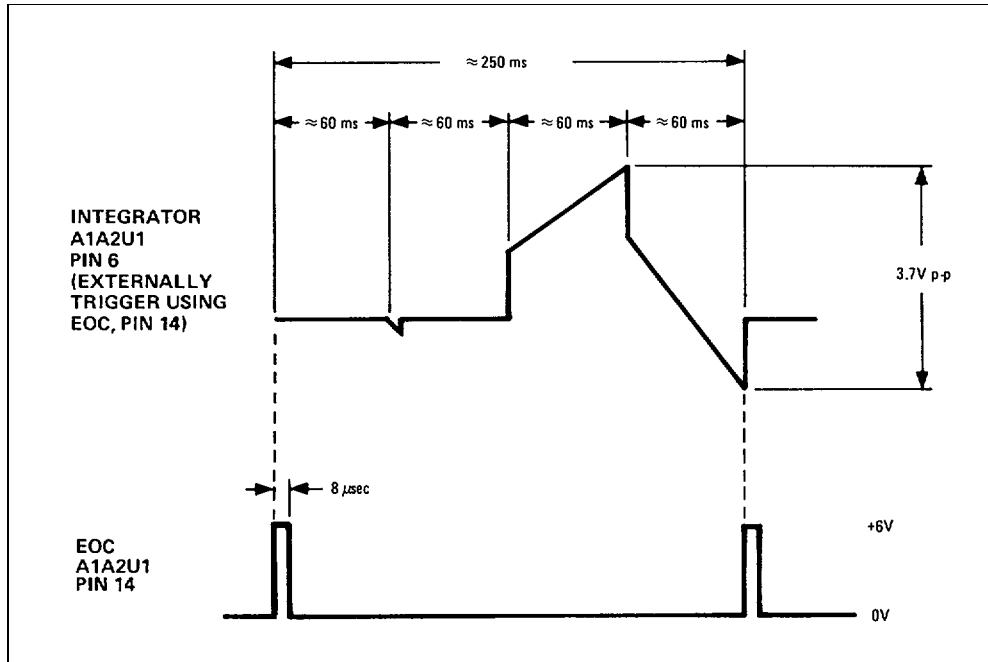
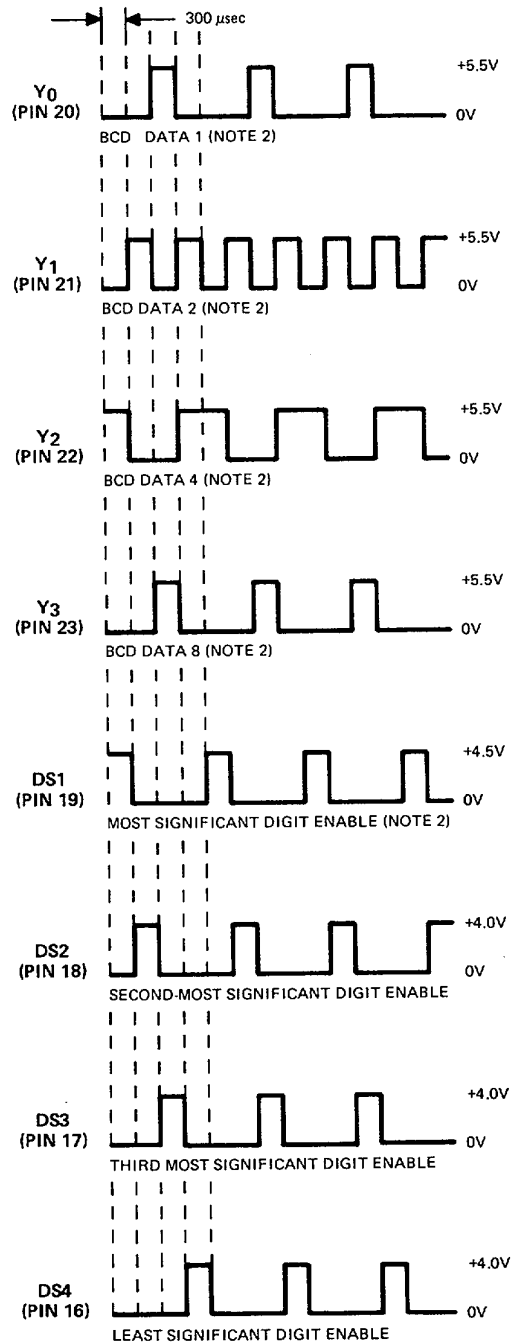

Figure 8-8. Integrator and EOC Waveforms for FREQUENCY MHz Display of 1296 MHz

Table 8-3. Truth Table for A2DS1 Display

A1A2U1 Data Output				Decimal Equivalent	A1A1DS1 Display
Y ₃	Y ₂	Y ₁	Y ₀		
0	0	0	0	0	-1
0	0	1	1	3	-1
0	1	0	0	4	1
0	1	1	1	7	1
1	0	1	0	10	-
1	0	1	1	11	-
1	1	1	0	14	Blank
1	1	1	1	15	Blank



NOTES

1. TRIGGER OSCILLOSCOPE EXTERNALLY USING EOC ((END OF CONVERSION), A1A2U1 PIN 14).
2. DURING THE TIME INTERVAL THAT DS1 LINE IS HIGH,THE DATA ON PINS 20 THROUGH 23 IS NOT STANDARD BCD CODE. SEE TABLE 8-2.

Figure 8-9. A1A2U1 Outputs for FREQUENCY MHz Display of 1296 MHz

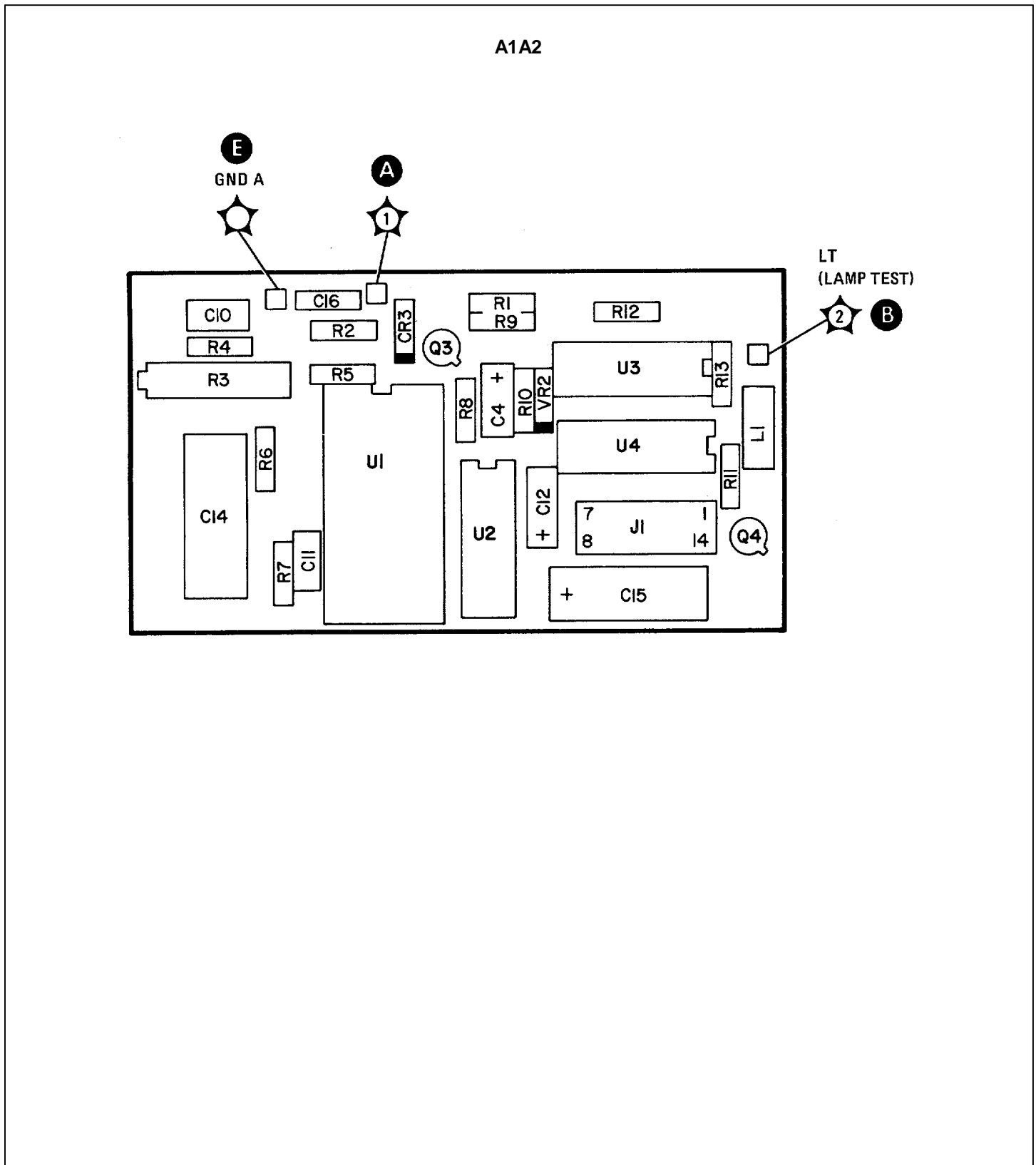

Figure 8-10. A1A2 DPM Driver Component Locations

THIS PAGE MISSING NOT AVAILABLE FOR DIGITIZATION.

PAGES
8-23 through 8-24

A2 FRONT SWITCH ASSEMBLY CIRCUIT DESCRIPTION

Functions of the switches and potentiometers on Front Switch Assembly A2 and Front Switch Board Assembly A2A1 are covered in the circuit descriptions for the electronic assemblies they control. Disassembly and repair procedures for the Front Switch Assembly are at the back of this section (following Figure 8-47).

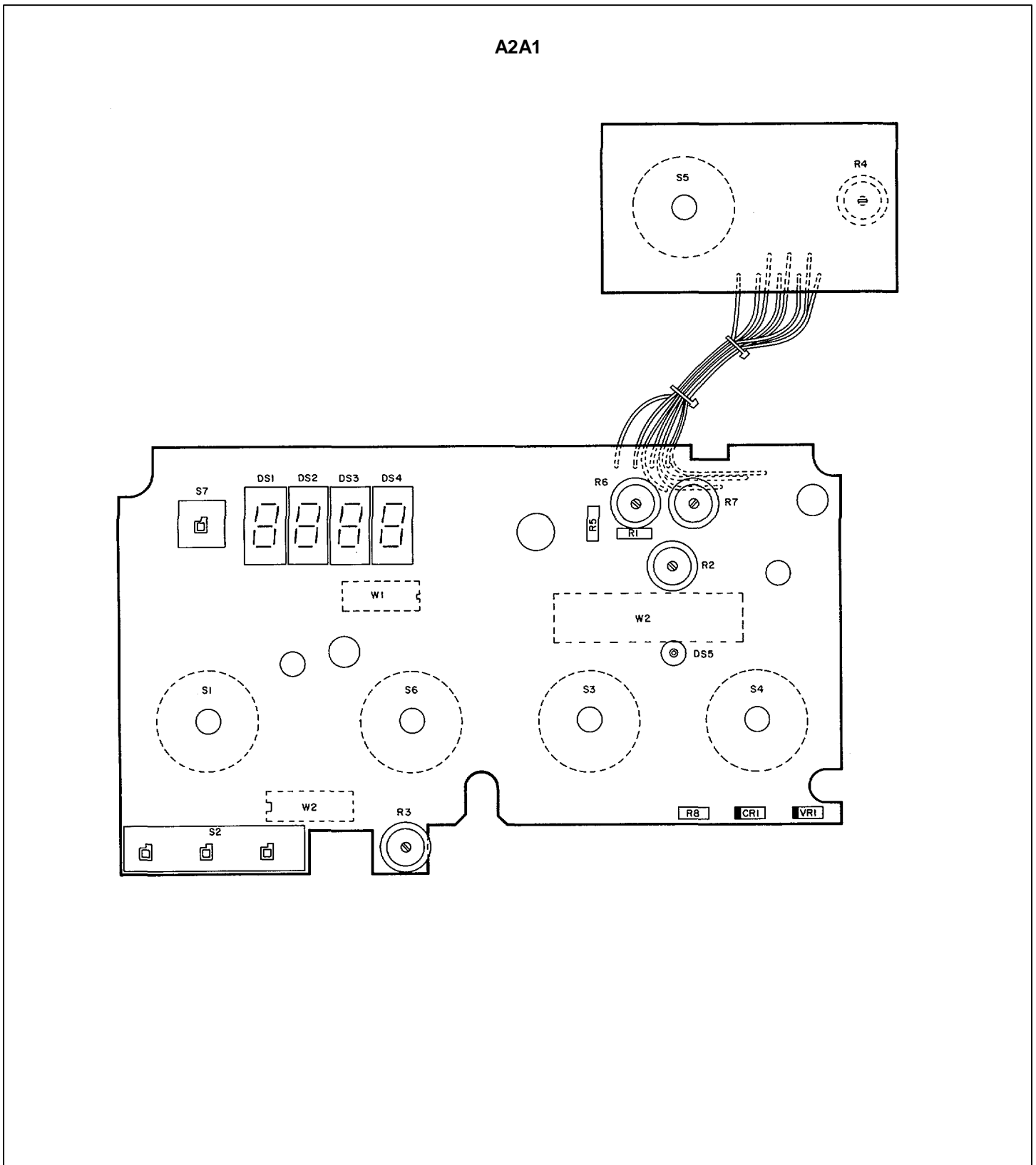

Figure 8-12. Front Switch Board Assembly A2A1, Component Locations

THIS PAGE MISSING NOT AVAILABLE FOR DIGITIZATION.

PAGES
8-27 through 8-28

A3, U1, A4, A5, A6 CIRCUIT DESCRIPTIONS

A3 Input Attenuator Circuit Description

The 8558B input attenuator (Figure 8-14) is a 50-ohm, precision, coaxial step attenuator. Attenuation in 10 dB steps from 0 dB to 70 dB is accomplished by switching the signal path through one or more of the three resistive pads in a predetermined sequence. (Note that the input attenuator is not field repairable.)

U1, RF Input Limiter Circuit Description

The RF input limiter contains Schottky diodes which clamp the input signal voltage, protecting the mixer diodes in the First Converter Assembly A4. The typical limiting threshold is 1 mW (0 dBm). The limiter is not field serviceable.

A4 First Converter Circuit Description

The RF signal input (0.1 1500 MHz) passes through a 1550 MHz low pass filter to the mixer diode assembly, U1. The output impedance of this low-pass filter seen from the mixer is effectively a short circuit at 2050 MHz, reflecting any IF power back to the mixer. The first LO input from YIG Oscillator Assembly A6 passes through a 3 dB power splitter consisting of two resistors, R1 and R2, and etched transmission lines. One of the power splitter outputs provides the front panel LO OUTPUT; the other output is through a balun (short piece of semi-rigid coaxial transmission line) to provide drive voltage to the mixer diodes. The LO signal is coupled to one mixer diode through the balun shield and to the other mixer diode through the balun center conductor. This arrangement splits the LO signal voltage evenly between the two mixer diodes. The 2050 MHz output signal from the mixer (first IF) is split-line coupled to a 6 dB 'pi' resistive matching pad (R3, R4, and R5). A small block of polyiron is placed over the split-output line. The polyiron helps balance the mixer and absorbs harmonics of the mixing signals. A 5000 MHz low-pass filter etched on the A4 printed circuit board provides additional filtering to the 2050 MHz IF signal after the 6 dB pad. The signal is then coupled to Second Converter Assembly A5 through a semi-rigid coaxial cable.

A5 Second Converter Circuit Description

The IF signal from the First Converter is coupled into the Second Converter bandpass filter through coupling loop L3. The bandpass filter consists of three circular, slug-tuned cavity resonators operating as less than a quarter wavelength inductive transmission lines. The cavities provide high 'Q' for good selectivity at 2050 MHz. Coupling loops L4 and L5 provide coupling between the cavities. The 2050 MHz signal is loop coupled to the cathode end of second mixer diode CR1. The second LO signal is loop coupled to the anode end of CR1. The second local oscillator is a Colpitts type circuit operating at 1748.6 MHz. The capacitive 'fingers' etched on the A5A1 printed circuit board and the internal transistor capacitances of A5A1Q1 provide the positive feedback necessary to sustain oscillation. The oscillator tank circuit is a slug-tuned cavity, Z4. The signal from the second LO is coupled into cavity Z4 by a 4 - 40 machine screw extending down into the cavity. The second LO output is also available at test jack A5J3. The 1748.6 MHz local oscillator provides the drive for mixer diode CR1. The difference frequency between the first IF, 2050 MHz, and the second LO frequency, 1748.6 MHz, is 301.4 MHz. This 301.4 MHz signal is coupled through the matching filter to the A10 Second IF. The matching filter is a passive network designed to match the relatively high impedance of the second mixer, about 200 ohms, to the low input impedance of the second IF, about 50 ohms. The match may be optimized by adjusting A5L2, 2nd MIXER MATCH adjustment.

A6 YIG Oscillator Circuit Description

The YIG Oscillator is a transistorized thin-film microcircuit. It uses an yttrium-iron-garnet (YIG) sphere as the frequency determining structure. The YIG sphere is a ferromagnetic material whose resonant frequency is directly proportional to the applied magnetic field. The sphere is placed in the gap of an electromagnet to provide a magnetic tuning structure whose field (and thereby the oscillator's frequency) is linearly proportional to the drive current from Frequency Control Assembly A7.

The main coil is used for wide range sweeping and tuning with the coil current varying from approximately 50 to 8 mA. The FM coil is used only for narrow spans (1 MHz/DIV and less) with the coil current varying from approximately - 25 mA to + 25 mA.

The YIG Oscillator Assembly consists of three parts: a sealed magnet assembly which encloses the YIG sphere and oscillator; a bias board which uses discrete components to establish oscillator/amplifier bias and to protect against supply noise and voltage overloads; and a mu-metal magnetic shielding can.

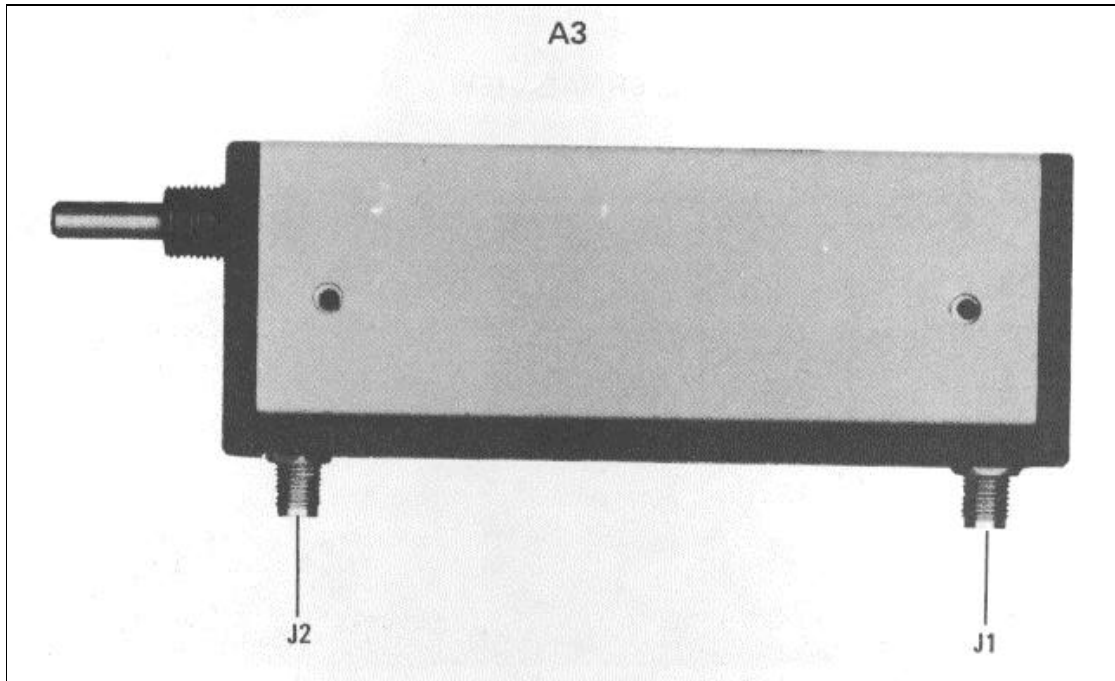

Figure 8-14. A3 Input Attenuator

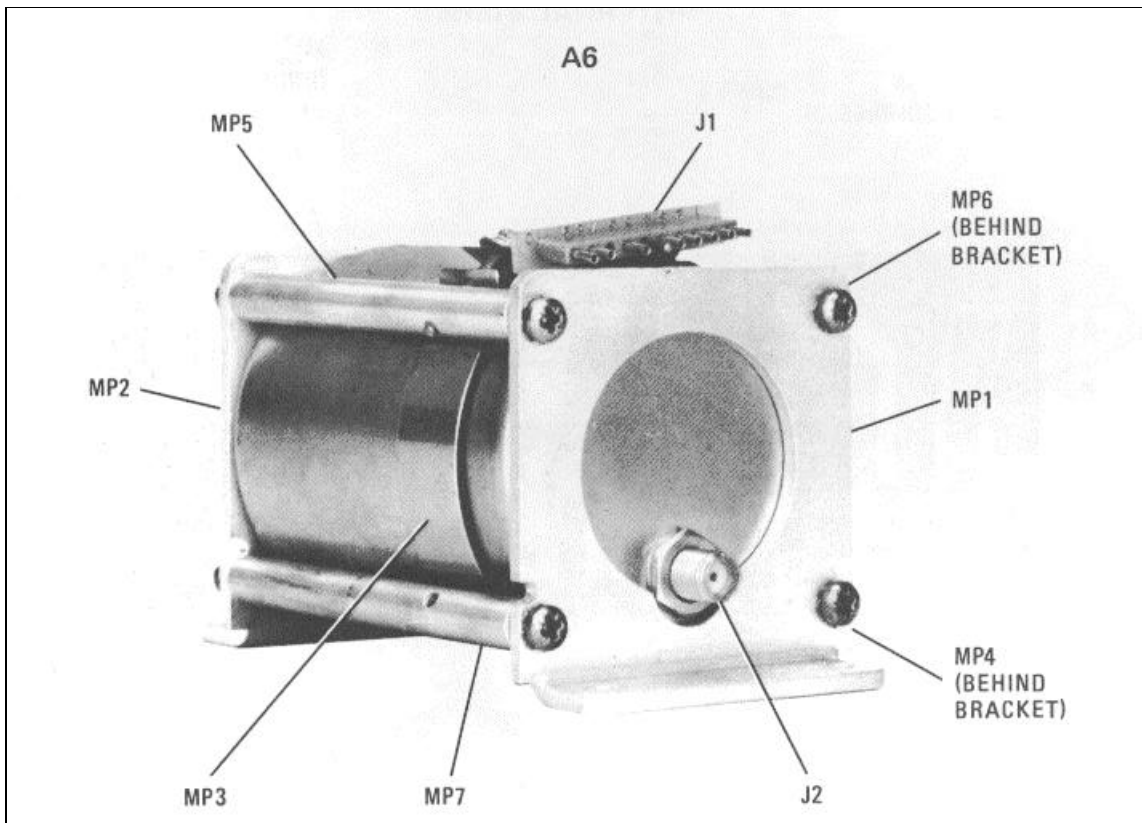

Figure 8-15. A6 YIG Oscillator

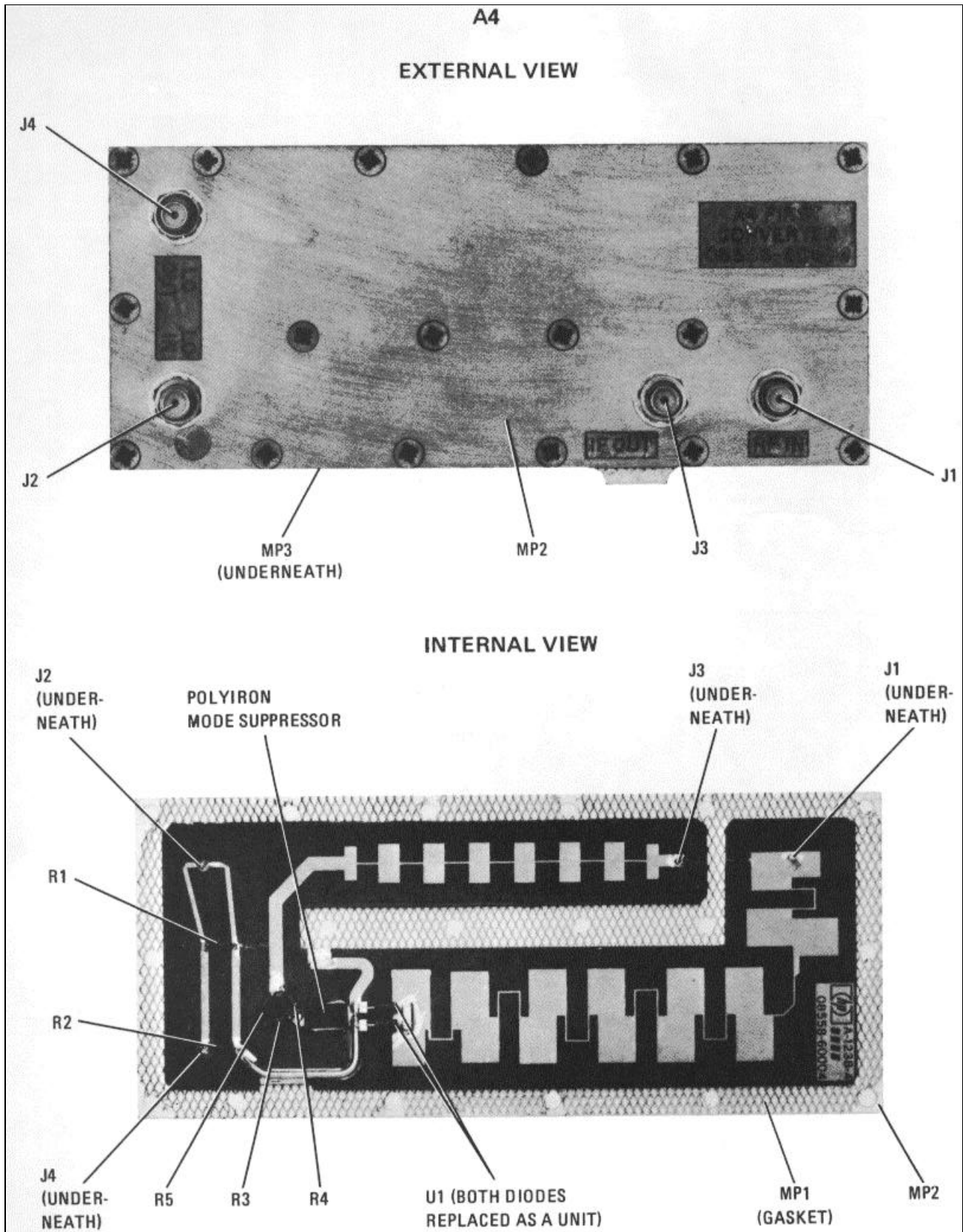

Figure 8-16. A4 First Converter, Component Locations

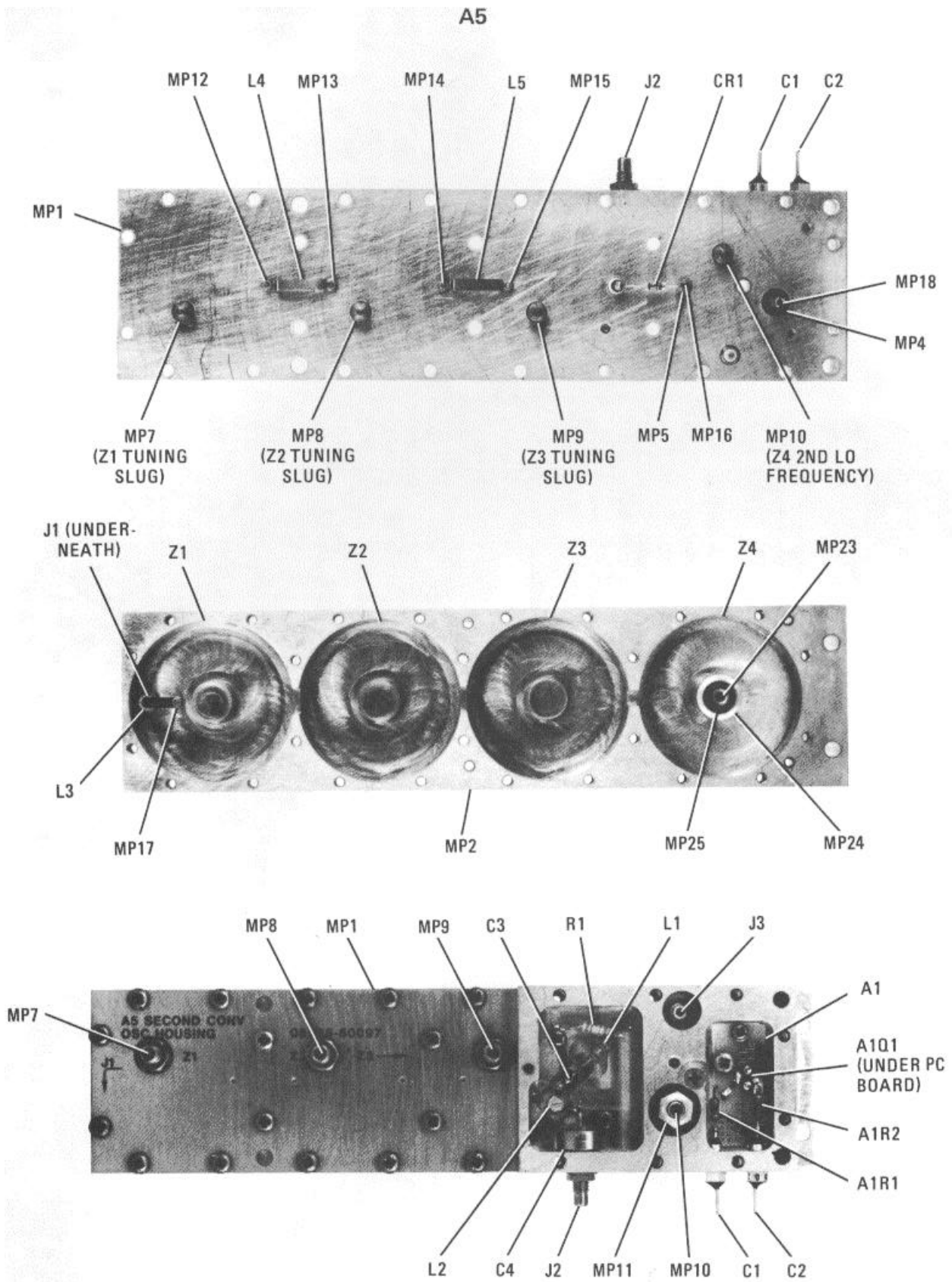

Figure 8-17. A5 Second Converter Assembly, Component Locations

THIS PAGE MISSING NOT AVAILABLE FOR DIGITIZATION.

PAGES
8-35 through 8-36

A7 FREQUENCY CONTROL CIRCUIT DESCRIPTION

General Description

Frequency Control Assembly A7 contains the circuitry to drive and control YIG Oscillator Assembly A6. The frequency is controlled by the sum of the sweep and tune voltages. The tune voltage is generated by the center frequency coarse and fine TUNING controls. The tune voltage is measured by the digital panel meter (DPM) voltmeter to provide the center-frequency digital readout. The sweep voltage, controlled by the FREQ SPAN/DIV switch, is generated in Sweep Generator Assembly A8. The YIG Oscillator has two driving coils: the main tuning coil and the FM coil. The tune voltage is applied to the main tuning coil driver. The sweep voltage is either summed with the tune voltage and applied to the main tuning coil driver or, in narrow frequency spans, it is applied to the FM coil driver. Gating circuits determine whether the sweep voltage is applied to the main or FM coil. The Frequency Control Assembly also contains separate low-noise voltage regulators to bias the YIG Oscillator and the 1748.6 MHz second local oscillator.

YIG Main Coil Fixed Driver

The YIG Main Coil Fixed Driver consists of differential amplifier A7Q7, a Darlington pair current source, A7Q5 and Q6, and a + 6V reference voltage from A7VR2 and R4. The fixed driver is used to tune the YIG oscillator to the minimum frequency of 2050 MHz.

The + 6V reference voltage is one input to A7Q7 and the other input, measured at TP3, is negative feedback that senses the voltage across A7R3 and R71. The operation of the fixed coil driver maintains a constant +6.0V across A7R3 and R71. A11 current through R3/R71 comes from the YIG main coil through Darlington current source A7Q5 and Q6. A7R3 is the 2.05 GHz lower frequency adjustment and sets the emitter current of A7Q5 and Q6. The current source provides the fixed current to determine the zero CENTER FREQUENCY point set by A7R3.

YIG Main Coil Swept Driver

The YIG Main Coil Swept Driver consists of a swept driver, A7U4, and a Darlington pair current source, A7Q1 and Q3. The swept driver tunes the YIG oscillator over the frequency range of 2050 MHz to 3550 MHz. The inputs to A7U4 are the Coarse and Fine TUNING voltage from the Tune Summing Amplifier, and the attenuated sweep ramp from the Sweep Buffer. The output from A7U3 is the attenuated sweep only when 2 MHz/DIV or wider frequency spans have been selected. In narrower frequency spans, only the sum of the TUNING voltages is applied to the main coil swept driver. The attenuated sweep and TUNING voltages are summed across A7R49 and R52 and then applied to the noninverting input of A7U4. Diode A7CR3 prevents the input of the swept driver from going negative and driving it into cutoff. A7U4 drives the current source which converts the voltage at the emitter of Q1 into current to drive the YIG main tuning coil.

The current from A7Q1/Q3 is summed with the current from the fixed driver current source, A7Q5/Q6, to increase the main coil current synchronously with the TUNING and sweep voltages. The YIG upper frequency 3.55 GHz is set by A7R1 (coarse adjust) and A7R2 (fine adjust). The emitter of A7Q1 is connected to the inverting input of A7U4 to provide a voltage proportional to the collector current of Q1/Q3 to be used as negative feedback.

Frequency AnA10g Output for Blanking. The emitter of A7Q1 also drives the base of A7Q2. A7Q2 is an emitter follower that provides the frequency anA10g output voltage to Third Converter Assembly A3 and to the Sweep Ramp High/Low Limit Comparator (A15U1) of Vertical Driver and Blanking Assembly A15. (See A15 Schematic.)

Coarse and Fine TUNING. The Coarse and Fine tuning voltages from control potentiometers A2R1 and A2R2 (shown on A2 schematic) are applied to the noninverting and inverting inputs respectively of A7U2. A7U2 sums these voltages and applies the voltage sum to the junction of A7R52 and R53. It is in turn summed with the attenuated sweep signal from the output of the sweep buffer A7U3 if 2 MHz/DIV or wider frequency spans have been selected. In narrower frequency spans, the input of buffer A7U3 is grounded so only the summed tuning voltages are applied to A7U4.

YIG FM Coil Driver

The FM Coil Driver consists of A7U1, Q17, Q18, and FM adjust R6. Selecting 1 MHz/DIV and narrower frequency spans enables the YIG FM Coil Gate, allowing the attenuated sweep to be applied to the YIG FM Coil Driver. (A7Q15 is on and Q16 is off.) A7U1 converts the sweep ramp voltage into current to drive the YIG FM coil. Transistors A7Q17/Q18 are biased at cutoff and provide additional current drive. The FM adjust, A7R6, sets the maximum FM coil current.

YIG Main and FM Coil Gates

The YIG Coil Gates determine which YIG coil is used to control the YIG oscillator frequency. The YIG Coil Gates are selected by the Scan Select which is controlled by FREQ SPAN/DIV control A2S6.

YIG Main Coil Gate. When 2 MHz/DIV and wider frequency spans are selected, the base of transistor A7U5C is returned to 12.6V through A7R11 and A8R131. A7U5C is turned off and the collector rises to about 5V while the emitter drops to near 12.6V. The collector of A7U5C turns on U5E and U5D, and these two transistors then turn off FETs Q15 and Q24 respectively. The emitter of A7U5C turns off U5A and U5B, which then turn on FETs Q16 and Q20. With A7Q20 conducting and A7Q24 open, the attenuated sweep is applied to sweep buffer A7U3 and YIG main coil swept driver A7U4 to control the YIG oscillator frequency. FET A7Q15 is turned off preventing the attenuated sweep input from reaching the YIG FM Coil Driver, and A7Q16 is turned on, grounding the input to the YIG FM coil driver.

YIG FM Coil Gate. The selection of 1 MHz/Div and narrower frequency spans with FREQ SPAN/DIV control A2S6 applies + 15V to the input of A7U5C. The + 15V turns U5C on; FETs Q20 and Q16 are turned off, and FETs Q24 and Q15 are turned on. This enables the YIG FM coil gate, allowing the sweep signal to be applied to the YIG FM Coil Driver. A7Q20 prevents the Attenuated Sweep input from reaching the sweep buffer A7U3 and A7Q24 grounds the input of A7U3. However, the tuning voltage from the tune summing amplifier is still applied to the YIG main coil swept driver.

Main Coil Filter

When the narrower frequency spans are selected, the + 15V from FREQ SPAN/DIV switch A2S6 is also applied to A7Q4 in the main coil filter. The main coil filter consists of FET switch A7Q4, R75, and C13/C14. The filter provides noise filtering in the 1 MHz and narrower frequency spans. With the FET switch closed, the filter is connected in parallel with the YIG main tuning coil.

Meter Ranging

The DPM is a digital voltmeter which measures the TUNING voltage at the output of the tune summing amplifier. The output of the tune summing amplifier, approximately 0 to -10V, is divided down to 0 to 1.5V at pins 2 and 5 of A7U6 by A7R53 and R50. This provides a 1 mV/MHz voltage to the DPM. The FREQ ZERO adjust R3 (shown on A2 schematic), A7R43, and A7R54 enable this voltage to be offset 4 15 mV to zero the DPM. The FREQ ZERO adjustment compensates for the changes in the frequency of the YIG oscillator caused by temperature drift.

A7U6A functions as a comparator and A7U6B as a switchable XI/X10 gain stage. When the instrument is tuned to a frequency below 198.4 MHz, the voltage at A7U6 pin 2 is less than 198 mV. Since the voltage at A7U6 pin 3 is adjusted to be approximately 198 mV, the output at A7U6 pin 1 is positive. This turns on Q19, causing A7U6B to have a gain of approximately 10 and results in an output voltage at pin 7 of 10 mV/MHz.

When the instrument is tuned above 198.4 MHz, A7U6A pin 1 goes low, turning Q19 off, causing A7U6B to have a gain of 1. This results in an output voltage at pin 7 of 1 mV/MHz. The output of A7U6A pin 1 is also used to turn A7Q25 off to turn off the decimal point. The positive feedback from the emitter of A7Q25 to A7U6A pin 3 provides hysteresis for rapid switching of the X1/X10 crossover point. A7CR6 and CR7 provide proper biasing for FET Q19. OFS adjustment A7R72 compensates for input offset of A7U6B.

+ 14.5V Regulator The + 14.5V Regulator consists of series regulator A7Q8, driver Q10, and reference amplifier Q9 and Q11. The +6.2V developed across zener diode A7VRI provides the base reference for A7Q9. This is compared to the voltage at the base of A7Q11 which senses the + 14.5V output across voltage divider A7R28, R29, and the + 14.5V adjust R5. Should the output voltage increase, A7Q11 conducts more, decreasing the conduction of A7Q9 and driving the base of Q10 more positive. This decreases the drive current to A7Q8 and causes the output voltage to drop (return to + 14.5V). A7C4 provides stability compensation and some additional noise filtering at the output.

The + 14.5V supply is used for the positive supply on A7U2, U3, U4, and Q7. It is also used on Sweep Generator Assembly A8 as the voltage reference that sets the 5V to + 5V ramp amplitude. The + 14.5V is also applied to Second Converter A5 as the positive supply for the 1748.6 MHz second local oscillator.

+ 6.00V Reference Voltage Regulator

The + 14.5V at A7R32 and the +6.2V dropped across A7VR2, develop the +6.00V reference voltage. A7R4 REF V adjusts the voltage at TP6 to + 6.00V.

-10V Regulator

The regulated + 14.5V provides a reference voltage for voltage divider A7R34 and R35 for the -10V regulator. The -10V regulator consists of series regulator A7Q12 and reference amplifier A7Q13 and Q14. Should the -10V tend to become more positive (less negative), A7Q13 decreases its conduction and turns A7Q14 on harder. A7Q14 then increases the conduction of A7Q12, dropping the output voltage back to -10V.

The -10V supply is used for the negative supply on A7U2, U3, U4, and Q7. It is also used as the negative supply for the A6 YIG Oscillator and the second local oscillator in A5.

Calibrate Single Shot

The calibrate single shot circuit consists of A7Q23, Q22, and Q21. The circuit is activated when the front panel FREQ CAL button is pressed. With the FREQ CAL switch A2S1 (shown on A2 schematic) closed, the YIG Oscillator is tuned to its lowest frequency. Releasing the FREQ CAL button returns the YIG Oscillator to the previous operating frequency.

Pressing the FREQ CAL button shorts the + 6V line to ground, discharging A7C8 and turning A7Q23 off. The emitter of A7Q22 is grounded, turning it on, and its collector goes low, turning off FET switch A7Q4. The main coil filter is now disabled and the charge held on A7C13/C14 remains the same during the calibration sequence. The charge voltage represents the previous operating frequency. The ground on the + 6V line is applied to the base of A7Q7, disabling the YIG main coil fixed driver. When the + 6.0V line is grounded, the output of the coarse TUNING control is grounded; the YIG main coil swept driver is disabled by the output from A7U2. With both YIG main coil drivers disabled, the magnetic current is removed and the magnet hysteresis is cancelled.

When the **FREQ CAL** button is released, the +6.0V reference line jumps to approximately + 1V. The charge on capacitor A7C8 turns on A7Q23 which then turns on Q21. A7C8, Q21, and Q23 form a Miller Integrator and the +6.0V reference line slowly charges to +6.0V. This takes about 0.3 second and prevents the introduction of transients into the main coil. However, as long as the + 6.0V reference line is charging; the conduction of A7Q23 keeps FET switch A7Q4 off, still disabling the main coil filter. The charge on A7C13/C14 has no path for discharge and remains the same. This allows the YIG Oscillator to return to the previous frequency faster since A7C13 and C14 do not have to be recharged.

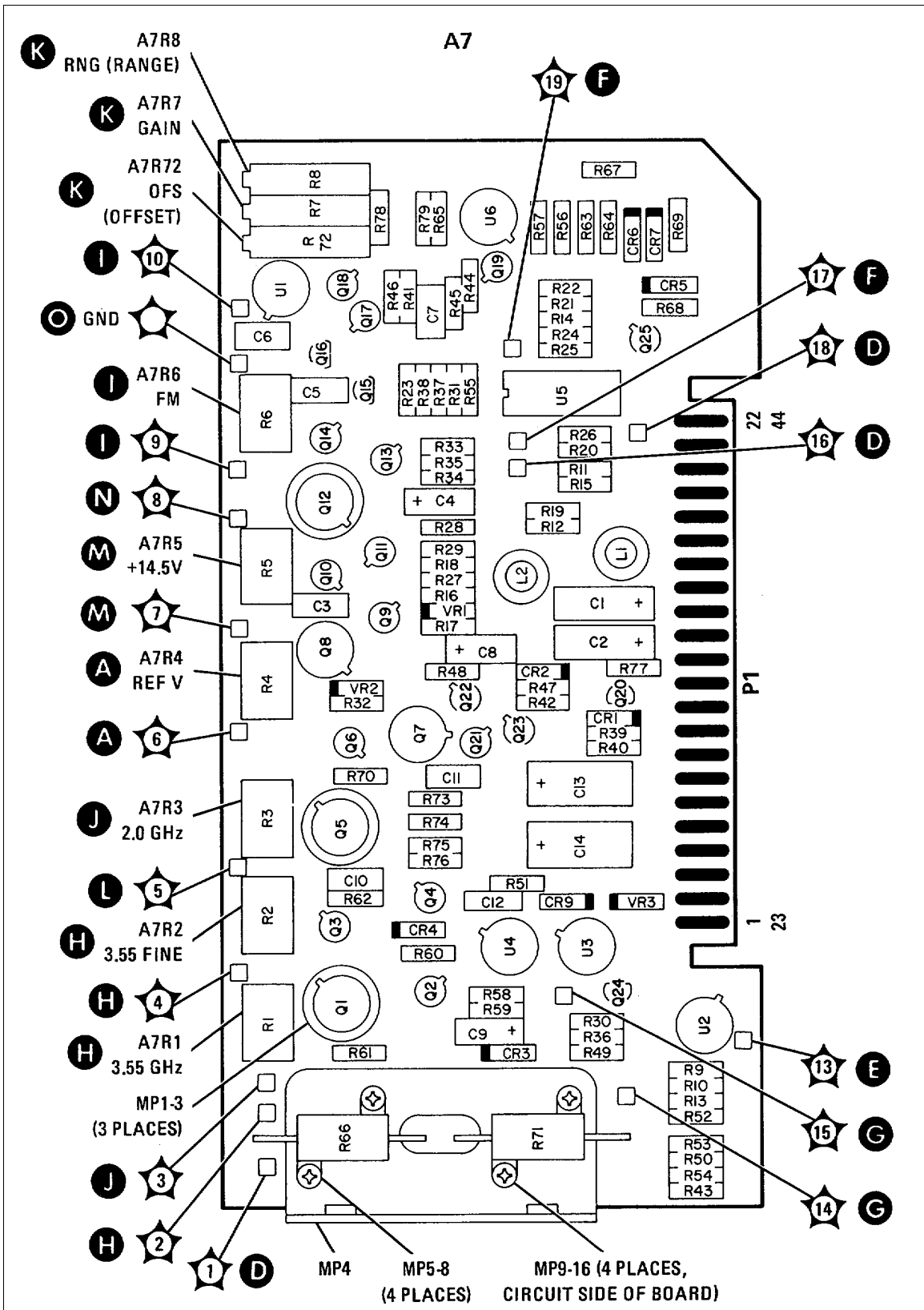

Figure 8-19. A7 Frequency Control Assembly, Component and Test Point Locations

THIS PAGE MISSING NOT AVAILABLE FOR DIGITIZATION.

**PAGES
8-43 through 8-44**

A8 SWEEP GENERATOR CIRCUIT DESCRIPTION

General Description

The Sweep Generator Assembly generates a -5 volt to + 5 volt linear sweep voltage. The sweep voltage controls the frequency of YIG oscillator Assembly A6, and also controls the horizontal deflection of the CRT beam. The SWEEP TIME/DIV control varies from 0.1 mSEC/DIV to 10 SEC/DIV so the full scan sweep time varies from 1 ms to 100 sec. The sweep may be synchronized with either the video input or the line voltage. Manual and free run modes are also provided. A single sweep may be started or stopped with the front panel TRIGGER switch. A retrace voltage is generated and applied to Vertical Driver and Blanking Assembly A15.

Sheet 2 of the A8 schematic (Figure 8-23) shows the resolution bandwidth control circuit, the video filter, the sweep attenuator circuit, and the + V sweep offset circuit. The resolution bandwidth control circuit has three purposes. First it provides the bandwidth filter control current to the PIN diodes on Bandwidth Filter Assemblies A11 and A13. Second, it provides current to the sweep generator current source (AST line) to control the AUTO sweep time circuit as a function of resolution bandwidth. Third, it switches in the proper capacitor for the RC lowpass video filter to provide video filtering as a constant percentage of resolution bandwidth. The sweep attenuator circuit attenuates the sweep ramp to Frequency Control Assembly A7 in proportion to the FREQ SPAN/DIV selected. It also provides a current to the sweep generator current source (AST line) to control the automatic sweep time circuit as a function of frequency span per division. The + V sweep offset circuit offsets the ramp voltage by 5 volts so the ramp voltage, when START frequency is selected, is from 0V to + 10V instead of 5V to + 5V.

Sweep Generator Circuit

The sweep ramp is generated in the following cycle. (See Figure 8-21.)

When transistor Q10 turns on, the sweep ramp is initiated. At the beginning of the sweep cycle, the voltage at TP3 is -4V and dead-time capacitor C15 is charging toward + 15V through R33. When the anode voltage on CR11 reaches + 1 .5V, Q10 turns on and the TP5 voltage becomes + 3V.

Pin 2 of U1 is at -5V and comparator U1 toggles to its positive supply voltage of + 14.5V. CR5 is now reverse biased. The current source can begin charging timing capacitors C3 and C4 positively, forming the positive slope of the sweep ramp.

As the sweep ramp level approaches + 5V at TP8, the U1 feedback circuit takes control, holding pin 2 of U1 at 2.68V and temporarily bringing pin 6 out of saturation. The anode voltage of zener diode VR1 equals the voltage at pin 6 minus 10V:

$$E_{VR1} = E_{pin6} - 10V$$

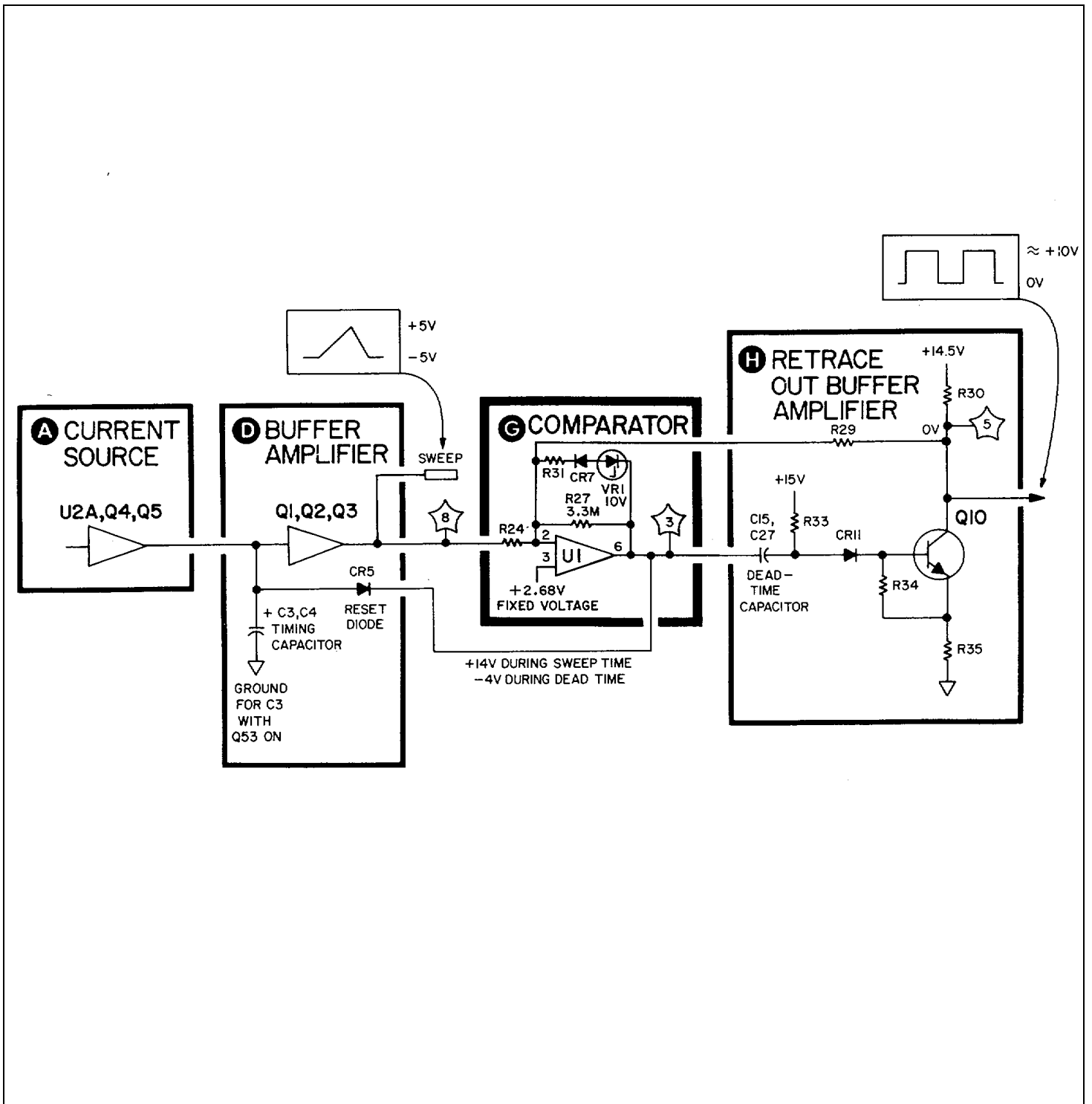

Figure 8-21. Simplified Schematic of Sweep Generator in AUTO Mode

As the voltage at U1 pin 6 (TP3) decreases, the anode voltage of VR1 decreases. At some time (when the level of the sweep ramp at TP8 is + 5V), the anode voltage of VR1 will no longer forward bias CR7, and the zener feedback loop opens. At this point, the 3.3 megaohm feedback loop becomes active and U1 saturates again. The comparator toggles, this time toward the negative operational amplifier supply, and 4V appears at TP3.

The -4V at T3 forward biases CR5. Timing capacitors C3 and C4 discharge through CR5, forming the negative slope of the sweep ramp. Dead-time capacitor C15 discharges.

The endpoints of the sweep ramp at TP8, 5V and + 5V, are controlled by the voltage divider R21, R24, R29, and R30 or R35, and by U1 and its feedback loops. U1 controls the ramp voltage as it maintains 2.68V at pin 2.

At the end of the ramp, when CR5 is forward biased, and the comparator output (pin 6 of U1) is approaching its negative supply, U1 uses Q1 and Q3 to maintain 2.68V at pin 2. Q10 is off, and the voltage divider R21, R24, R29, and R30 produces -5V at TP8.

At the beginning of the ramp, when CR5 is reverse biased, and the comparator output is approaching its positive supply, U1 again maintains 2.68V at pin 2. This time, Q10 is on, and voltage divider R21, R24, R29, and R35 produces + 5V at TP8.

Fast/Slow Sweep Time Operation. The ST6 control line from Front Switch Assembly A2A1, selects timing and dead-time capacitors C3, C4, C5, and C27, to control fast and slow sweep times. If the same amount of charging current is supplied to a larger capacitor, it charges at a slower rate.

Timing capacitors C3 and C4 are used to provide fast and slow sweep operation. When a fast sweep time (ms/div) is selected at TIME/DIV switch A2A1S3, the ST6 (FAST SWEEP) control line is grounded, turning off Q55 and Q53. With Q53 off, C3 and C4 are in series and the timing capacitor becomes C4. With Q55 off, the + 15V at R57 back biases CR9 and CR6, so C27 is switched out of the dead-time circuit. the dead-time (about 0.4 ms) is set by C15. In sweep times greater than 1 ms/div (or in AUTO sweep times), the ST6 (FAST SWEEP) control line is open, Q55 and Q53 are both on. With Q53 on, a ground is provided for C3 and it becomes the timing capacitor. CR6 and CR9 are on because of the conduction of Q55. C15 and C27 are in parallel, so the longer dead-time (about 7.5 ms) is set by C27.

When selecting FREE RUN mode (A2A1S4), + 15 volts is routed to the voltage divider, R59 and R60, via the TRIG control line. CR10 is reversed biased.

FREE RUN TRIGGER Operation. The circuit free runs and Q10 conducts when U1 switches on and off at a time determined by the RC time constants.

VIDEO TRIGGER OPERATION. When the video mode is selected (VIDEO position on A2A1S4 switch), CR10 is forward biased by R59, and Q10 is off. The sweep ramp is generated by turning on Q10 with a negative pulse from the pulse shaper circuitry. The negative pulse is applied to the emitter of Q10.

The pulse shape consists of a Schmitt trigger (Q39 and Q40), a differentiator (C12 and R55), and an emitter follower (Q12). The Schmitt trigger produces a pulse which exists as long as the video trigger information on the SYNC line is above a certain dc level. When the TRIGGER switch is in VIDEO position, video information from Vertical Driver and Blanking Assembly A15 is routed through the switch to the base of Q40. Q40 is normally off and Q39 is conducting. During the positive portion of the SYNC signal, Q40 turns on, turning Q39 off. C7 accelerates the Q39 switching. When Q40 switches on, the negative change at the collector is differentiated by C12 and R55, and coupled through Q12 to the Q10 emitter. The negative pulse turns on Q10. CR8, R32, and VR1 keep Q10 on while the ramp is being generated. After the ramp is completed, the circuit returns to its dead-time state and another trigger is required to generate another sweep. Trigger pulses from Q40, which may occur during the sweep, have no effect since Q10 is already on.

LINE TRIG Operation The sweep may be synchronized with the ac line voltage in the same manner as described in VIDEO operation. With TRIGGER switch A2A1S4 in LINE position, the ac line from the mainframe power transformer is connected to the Schmitt trigger (Q40 and Q39) input. A16R2 and A16C2 on the motherboard attenuate the ac line signal to approximately 2 volts p-p and filter any line spikes.

SINGLE Sweep Trigger and Abort. Q10 is initially held off by R59 and CR10. Q9 is on, and voltage divider R37 and R38 charges C16 to +2.8V. When the trigger switch A2A1R4 is set to SINGLE sweep (spring-loaded position), + 15V is applied to R62 turning on Q11. This shorts the positive end of C16 to ground and produces a negative pulse at the emitter of Q10. This turns Q10 on starting a sweep.

During the generation of a sweep, Q9 is off and the voltage divider R37 and R38 charges C16 to 4V. The sweep may be aborted (reset to 5V) by pressing the SINGLE switch to the spring-loaded position. This switches on Q11. The negative end of C16 is shorted to ground, a positive pulse is generated at the emitter of Q10, and Q10 is turned off aborting the sweep.

MANUAL Sweep Control

Manual control of the sweep is obtained with the TIME/DIV switch A2A1S3 in MAN position. A ground is applied to the base of Q38 and Q37 by the ST7 line from A2A1S3 in all sweep modes except manual; the ground holds Q38 and Q37 off. With A2A1S3 in MAN position, Q38 and Q37 are turned on. Q37 turns Q10 on and keeps it on. CR5 is on and the feedback loop to the timing capacitor is closed. Turning the MANUAL SWEEP control A2A1R4 changes the voltage at the collector of Q38 which changes the input current at U1 pin 2. Since the feedback current through R29 is constant, any change in manual sweep current must be compensated by a change in the current through R24, thereby varying the ramp output voltage.

Current Source

Current for the generation of the sweep is provided by the current source circuit. The temperature dependent power supply provides a nominal + 10V; Q6 is the temperature sensing element (diode). The following switches control current to operational amplifier U2A pin 2: RESOLUTION BW switch A2A1S5, FREQ SPAN/DIV switch A2A1S6, VIDEO FILTER potentiometer A2R5, and TIME/DIV switch A2A1S3. In the AUTO sweep time mode, the sweep time is controlled by the RESOLUTION BW, FREQ SPAN/DIV, and VIDEO FILTER which set the currents to U2A. These currents are summed by U2A to produce a voltage proportional to the log of the sweep time. Q4 is the current driver and converts voltage variations into current variations proportional to sweep time. The current is applied to the timing capacitors C3 and C4, in the buffer amplifier circuit.

Q7 provides temperature compensation for Q4. Q8 is a constant-current regulator for Q7. In AUTO, the sweep time is limited to 1 ms and longer because current is limited to 1 mA by Q5/R15.

In the calibrated sweep time/division mode, the gate of Q52 is grounded. This turns Q52 off and disconnects the currents proportional to RESOLUTION BW, FREQ SPAN/DIV, and VIDEO FILTER. Calibrated sweep times are now produced by the currents fed to U2A through R40 through R44. Those resistors are grounded in various combinations by SWEEP TIME/DIV switch A2A1S3 resistor network. (See A2 Schematic.)

XTAL Resolution Bandwidth Control

When a XTAL bandwidth is selected (30 kHz, 10 kHz, 3 kHz, 1 kHz), control line BW5 is released from + 15V on the front panel and is pulled to -.5V by Q13. This has four effects.

1. On the Bandwidth Filter boards CR2 and CR13 are turned off and Q3, Q6, CR8 and CR15 are turned on, allowing the XTAL filters to operate.
2. Q21 is turned off allowing BW7 to be pulled up to more than + -10V by CR18 and R82. This turns off the LC filter sections on the Bandwidth Filter boards.
3. Q14 is turned off allowing the voltage on BW6 to be controlled by the current through A8Q 19.
4. Q22 is turned off having an effect on sweep time which is discussed in detail later.

The current through Q19 is a function of the states (off or on) of Q15, Q17, Q42, the values of factory select resistors R74, R76, and R78, and the setting of R72 XTL (3 kHz adjustment). The off/on states of Q15, Q17, and Q42 are controlled by BW1, BW2, and BW3 which are controlled by the front panel RESOLUTION BW switch and are at either + 15V or some negative voltage. The amount of current through Q19 controls the bandwidths of the XTAL filter sections on the Bandwidth Filter boards.

LC Resolution Bandwidth Control

When an LC bandwidth is selected, (3 MHz, 1 MHz, 300 kHz, 100 kHz), control line BW5 is pulled to + 15V at the front panel. This has four effects.

1. On the Bandwidth Filter boards: Q3, Q6, CR8, and CR15 are turned off and CR2 and CR13 are turned on, thus blocking any signal from passing through the XTAL filter sections.
2. Q14 is turned on, pulling BW6 to -4V, which further defeats any possible action of the XTAL filter sections.
3. Q21 is turned on, allowing the voltage on BW7 to be controlled by the current through Q20.

The current through Q20 is a function of the states (off or on) of Q23, Q44, Q49, the values of factory select resistors R89, R92, and R95, and the setting of R85 LC (1 MHz adjustment). The off/on states of Q23, Q44, Q49 are controlled by BW2, BW3, and BW4 which are controlled by the front panel bandwidth switch and are either at + 15V or some negative voltage. The amount of current through Q20 controls the bandwidths of the LC filter sections on the Bandwidth Filter boards.

4. Q22 is turned on having an effect on AUTO sweep time which is discussed later.

Video Filter

The video filter is composed of front panel control A2R6, switch A2S2, and 8 capacitors on Sweep Generator A8. The amount of filtering is controlled by the Resolution Bandwidth setting through Q16, Q18, Q43, Q41, Q46, Q24, and Q45. These transistors switch in and out various combinations of filter capacitors to provide more video filtering when the resolution bandwidth is decreased. In LC mode, BW6 is low holding Q15, Q17, Q42, Q41 off and keeping C19, C20, C21 and C22 out of the circuit.

Switch A2S2 applies maximum video filtering for noise measure mode by switching in C26 through Q47.

Sweep Attenuator

The sweep attenuator circuit changes the amplitude of the sweep voltage applied to the Frequency Control A7 as a function of the FREQ SPAN/DIV selected. The attenuator attenuates the -5V to +5V ramp routed through XA8 pin 39 in a divide by 1, 2, 5, and 10 sequence from a divide-by-1 to a divide-by-200. The circuit also generates an auto-sweep control current used to control the AUTO sweep time circuit as a function of the frequency span.

The sweep attenuator has two voltage dividers buffered by the unity gain voltage follower U3. The divider at the input of U3 provides either a divide-by-two or a divide-by-five; the divider at the output of the U3 provides a divide-by-one, a divide-by-ten, and a divide-by-one hundred.

Assuming that FS3 (divide-by-two) is selected, + 15V turns on Q31 and Q32 grounds a 10K ohm resistor R113. The -5V to +5V ramp is divided across the input resistor R101 (10K ohms) and R113 (10K ohms). The ramp is now divided in half and applied to sweep buffer U3 pin 3. The dividers at the output of U3 (controlled by FS4 and FS5) have reversed control logic; they are normally connected to + 15V by A2A1S5 and open when selected. Q50 is a gate to drive Q30. When FS4 and FS5 are connected to + 15V, Q50 is off and Q30 is on, connecting the divide-by-one divider at the output of U3. If either FS4 or FS5 is open, Q30 is off and Q28 or Q26 is on, providing either a divide-by-10 or divide-by-100. AUTO sweep control current is applied to Q52 as a function of frequency span by Q35, Q31, Q33, Q27, and Q25 and the appropriate resistors. For narrow spans (1 MHz/DIV or less), when the YIG FM coil is swept, FS6 is connected to + 15V by A2A1S5. Q29 is on and the additional current in the AUTO sweep control is used to reduce the sweep time.

+ V Sweep Offset

Normally, START-CENTER switch A2A1S7 is in the CENTER position. The + 15V back biases Q54 and holds it off. Switching to START allows Q54 to conduct and adds 0.5 mA of current through R67 to offset the sweep ramp. When START frequency is used, the ramp excursion is from 0V to a positive voltage.

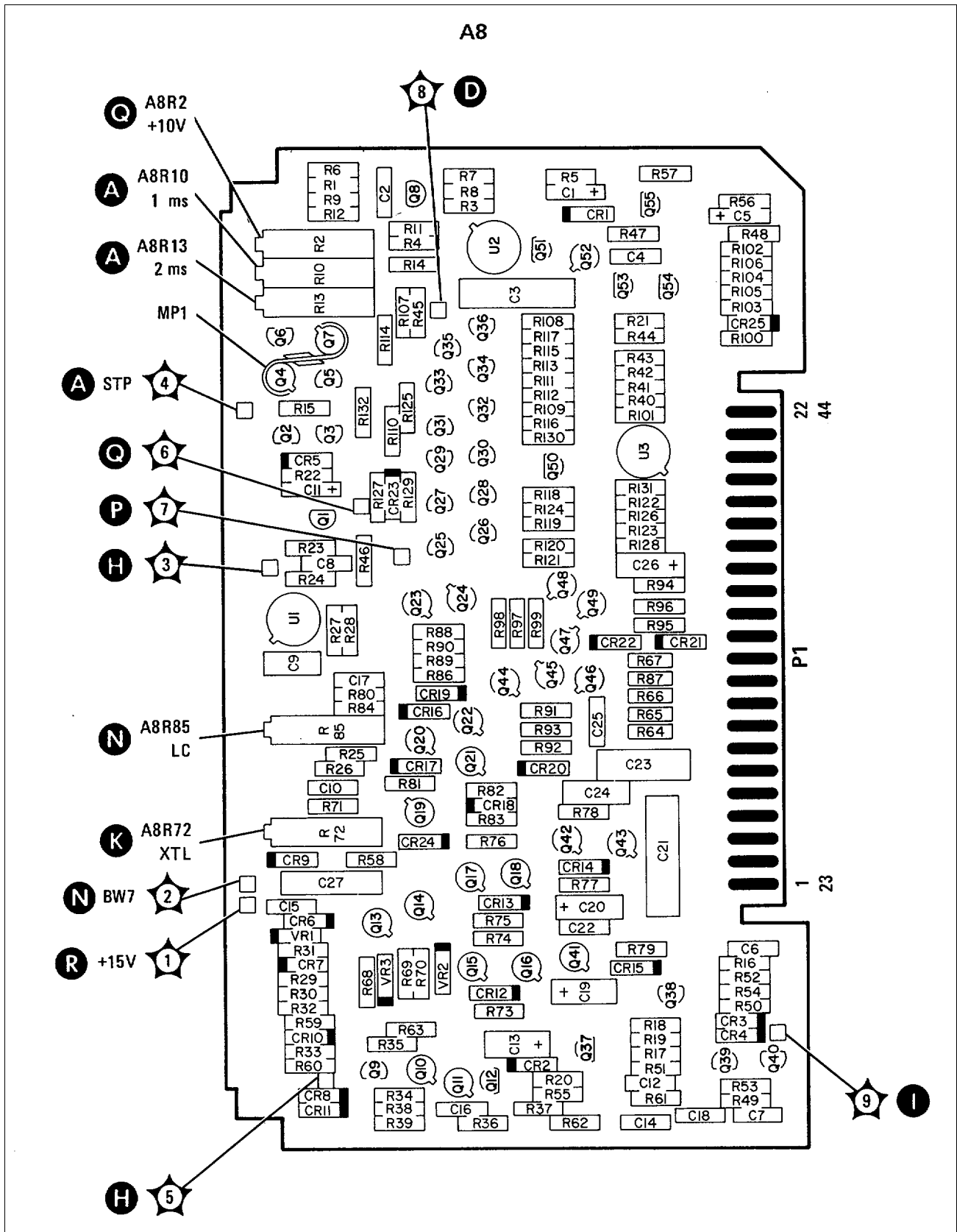

Figure 8-22. A8 Sweep Generator Assembly, Component and Test Point Locations

THIS PAGE MISSING NOT AVAILABLE FOR DIGITIZATION.

**PAGES
8-53 through 8-56**

A9 THIRD CONVERTER CIRCUIT DESCRIPTION

General Description

The Third Converter Assembly contains of a 280 MHz oscillator followed by a buffer amplifier, a balanced mixer, a matching filter, a 21.4 MHz amplifier, and a PIN attenuator. The 301.4 MHz second IF signal from A10 is mixed with the 280 MHz oscillator (third LO) in balanced mixer A9U1. The output from the mixer is the difference frequency, 21.4 MHz, which is applied to the matching filter. This is a 21.4 MHz bandpass filter which also acts as an inter-stage impedance matching device. The signal is then amplified by the 21.4 MHz amplifier and coupled to a divider network consisting of two PIN diodes A9CR3 and CR4, resistor R25, and the input impedance of the Bandwidth Filter No. 1 Assembly A11. PIN driver A9Q5 changes the bias of the PIN diodes as a function of frequency, compensating for input mixer frequency response. The 21.4 MHz third IF output signal is coupled to the input of Bandwidth Filter No. 1. The 280 MHz Oscillator also provides the front panel CAL OUTPUT 280 MHz -30 dBm signal. It is sometimes necessary to select a different value for R9 to provide the 30 dBm CAL OUTPUT level while maintaining the proper input level to the balanced mixer.

280 MHz Oscillator (Third LO)

The third local oscillator is a modified Colpitts circuit with a 280 MHz surface acoustic wave resonator (SAWR) A9Z1 in the positive feedback path to provide increased frequency stability. Inductor A9L3, across the SAWR, tunes out the SAWR shunt capacitance. The oscillator tuned circuit consists of capacitors A9C4, C5, and inductors L4 and L6. This tuned circuit ensures that the oscillator oscillates only on the proper overtone of the SAWR. Although A9L4 is called the LO FREQ adjustment, it is used to adjust for maximum LO output power and has only a slight effect on the output frequency. Inductor A9L5 provides a dc path for base bias of buffer amplifier A9Q2. Diodes A9CR1 and CR2 provide temperature compensation for the 280 MHz oscillator and indirectly stabilize the CAL OUTPUT level. Power is taken out of the oscillator through L6, which transforms the output to approximately 50 ohms at a level of 0 dBm. The output level of the circuit is controlled by 3RD LO PWR adjustment A9RS, which sets the emitter current of A9Q1 and allows adjustment for a 30 dBm 280 MHz front-panel CAL OUTPUT level. It is sometimes necessary to select a different value for A9R4 to provide the proper third LO output level. Buffer amplifier A9Q2 provides isolation for the 280 MHz oscillator and provides about 10 dB of power gain to the L port of balanced mixer U1. The buffer amplifier also provides the proper output level to the front-panel CAL OUTPUT (by selecting A9R9) for a given balanced mixer input.

Balanced Mixer (Third Mixer)

The third LO 280 MHz input to the L port of the balanced mixer is approximately + 10 dBm. The level of the second IF 301.4 MHz input to the X port of the mixer is about 12 dBm or less. The third mixer output (Port R) is the 21.4 MHz difference frequency produced by heterodyning the 301.4 MHz IF and the 280 MHz LO. The third mixer has a conversion loss of about 7 dB.

Matching Filter

The output of the balanced mixer is applied to the matching filter which consists of A9L9, C10, C11, C12, and L10. The matching filter is a 21.4 MHz bandpass filter which also serves as an impedance matching network. The circuit raises the low input impedance of the 21.4 MHz amplifier (about 10 ohms) to match the higher output impedance of the balanced mixer (about 50 ohms).

21.4 MHz Amplifier

The 21.4 MHz amplifier consists of A9Q3 in a common-emitter configuration and A9Q4 as an emitter follower. Transistor A9Q3 employs resistor A9R12 and zener diode A9VR2 to furnish base bias and negative feedback for gain control and stabilization. Resistor A9R12 is factory selected to provide the

proper gain of the Third Converter Assembly. Capacitor A9C14 is connected across A9VR2 to reduce zener noise. The output of the 21.4 MHz amplifier looks into a voltage-controlled attenuator consisting of two PIN diodes, A9CR3 and CR4, resistor A9R25, and the input impedance of the Bandwidth Filter No. 1 Assembly A11.

PIN Driver

The PIN diode resistance of A9CR3 and CR4 is controlled by the PIN driver A9Q5 and its associated circuitry. The base of A9Q5 is the summing point for the frequency anA10g voltage from the Frequency Control Assembly A7 and a dc level set by front-panel REF LEVEL CAL screwdriver adjustment A2R3. Setting the dc level by adjusting A2R3 calibrates the 8558B display at a given frequency, usually performed at 280 MHz. The frequency analog voltage is a dc level varying from + 0.6 volts to + 6.7 volts as a function of frequency. This frequency anA10g voltage at the base of A9Q5 compensates for input mixer response. SLOPE COMP adjustment A9R1 sets the amount of compensation required for a flat frequency response. The total current through the PIN diodes A9CR3 and CR4 is shaped by the emitter network of A9Q5. This network provides a change in current through the PIN diodes to cause a change of PIN diode resistance. The change in resistance is required to provide the proper log curve within an 8 dB range for the voltage-controlled attenuator.

A10 SECOND IF CIRCUIT DESCRIPTION

General Description

The Second IF Assembly contains a bandpass amplifier which provides a gain of approximately 16 dB at 301.4 MHz. It also contains a bandpass filter which provides further rejection of unwanted signals. The bandpass filter has a 3 dB loss, giving the Second IF Assembly a net gain of approximately 13 dB at 301.4 MHz. The 301.4 MHz IF output signal is coupled to Third Converter Assembly A9 by cable W7. This signal is the input to the X port of the balanced mixer on the Third Converter Assembly.

Bandpass Amplifier

The bandpass amplifier consists of A10Q2 in a common-emitter configuration, and A10Q1 connected to control the base drive and bias current of A10Q2. Capacitors A10C4, C5, C7, and C10 serve as decoupling for high frequencies. The gain of the bandpass amplifier is set by the high frequency characteristics of A10Q2, R5, and the small amount of inductance on the emitter connection of Q2. The emitter inductance is used to establish a 50 ohm input impedance and to help stabilize the current gain of A10Q2. Resistor A10R5 in parallel with the output resistance of A10Q2 establishes an output impedance of about 500 ohms. Components A10L2, C8, C9 and the collector capacitance (C_c) of Q2 form the collector tank circuit (see Figure 8-24). This tank circuit determines the center frequency of the bandpass amplifier and transforms the 500 ohm output impedance at the collector of A10Q1 down to 50 ohms. The output of the bandpass amplifier flows from A10C9 through a 50 ohm microstrip transmission line (etched on the printed circuit board) to the bandpass filter. The bandpass amplifier has a gain of about 16 dB from the base of A10Q2 to the 50 ohm output of A10C9.

Bandpass Filter

The output of the bandpass amplifier passes through a 301.4 MHz bandpass filter. The bandpass filter is made up of A10L3, L4, L5, C11, C12, C13, C14, C15 and adjustable piston-type capacitors A10C1, C2, and C3. Capacitors A10C11 and C15 are used to transform the bandpass filter input and output impedance to 50 ohms. Inductors A10L3, L4, and L5 are wound on a common coil form which provides mutual inductance coupling between filter sections. The bandpass filter has an insertion loss of approximately 3 dB and 3 dB bandwidth of about 12 MHz.

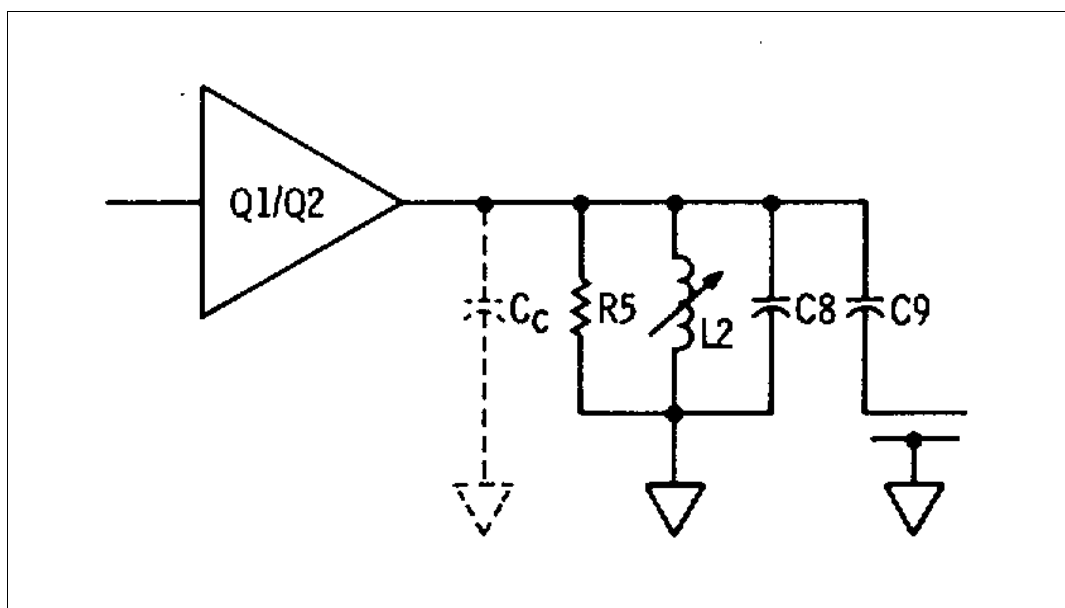

Figure 8-24. Bandpass Amplifier Tank Circuit, Simplified Schematic

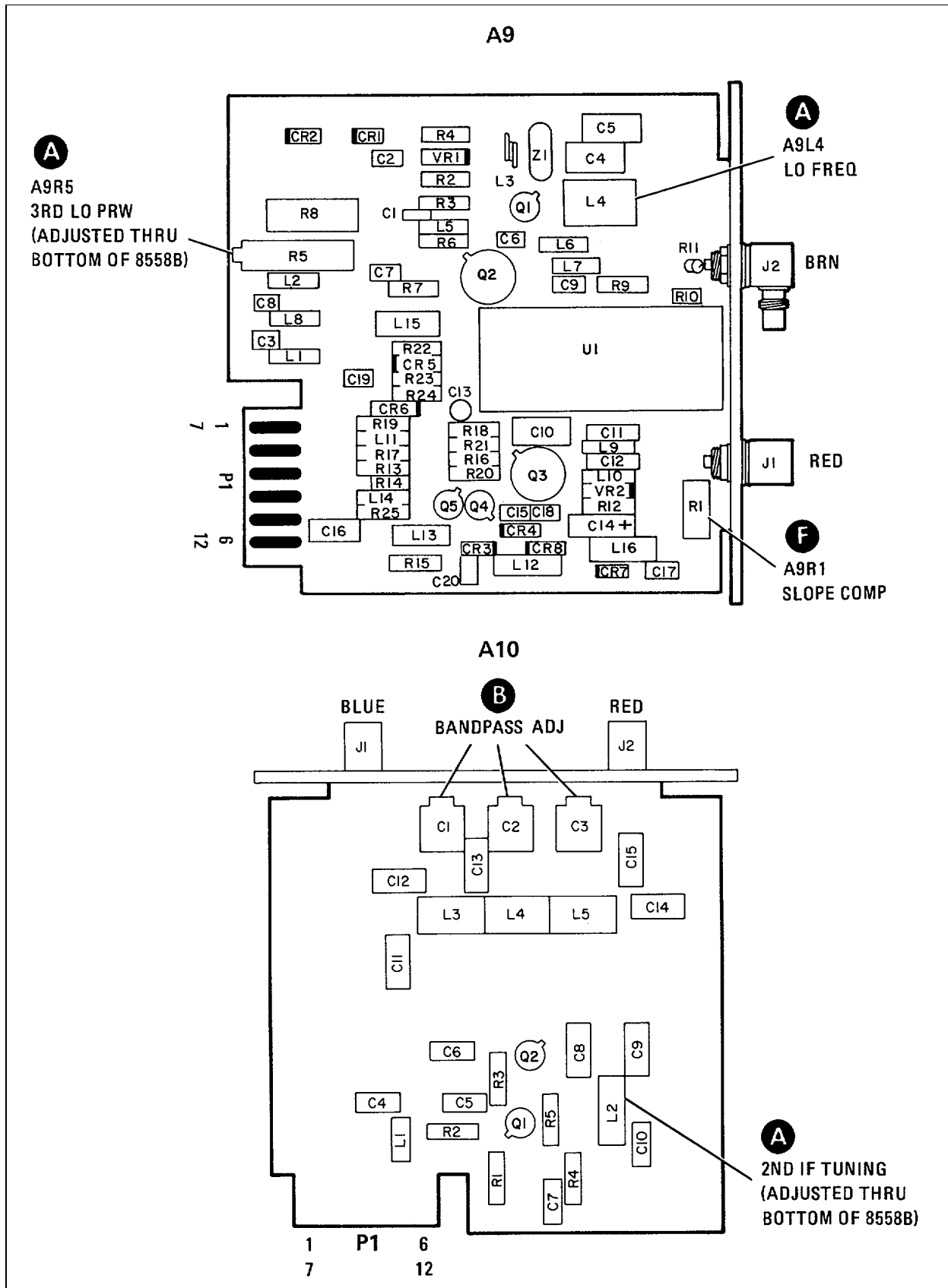

Figure 8-25. A9 Third Converter Assembly, and A10 Second IF Assembly, Component Locations

THIS PAGE MISSING NOT AVAILABLE FOR DIGITIZATION.

**PAGES
8-61 through 8-62**

A11 BANDWIDTH FILTER NO. 1 CIRCUIT DESCRIPTION

General Description

Bandwidth Filter No. 1 operates at 21.4 MHz and is variable in bandwidth from 3 MHz to 1 kHz. The front-panel RESOLUTION BW switch is used to select one of eight available bandwidth settings (3 MHz, 1 MHz, 300 kHz, 100 kHz, 30 kHz, 10 kHz, 3 kHz, or 1 kHz).

The narrower bandwidths (1 kHz through 30 kHz) are obtained from four synchronously tuned crystal filters; the four wider bandwidths (100 kHz through 3 MHz), from four synchronously tuned LC tank circuits. The four stages of bandwidth filters are on two similar printed-circuit boards, Bandwidth Filter No. 1 (A11) and Bandwidth Filter No. 2 (A13). Two LC tank circuits and two crystal filters are on each board. The four crystals in the two bandwidth assemblies (A11Y1, A11Y2, A13Y1, and A13Y2) are a factory-selected matched set. If replacement of a Bandwidth Filter assembly is necessary, the new board is shipped with two crystals installed. The other two crystals (which must be used to replace the existing two crystals in the good Bandwidth Filter assembly) are packaged separately and shipped with the new Bandwidth Filter board. In addition to the filter stages, each Bandwidth Filter provides 10 dB of gain in both LC and crystal filter operation. (There is some gain in the "unity" gain buffer amplifiers.)

10 dB Input Buffer Amplifier

The 10 dB input buffer amplifier functions as a non-inverting operational amplifier.

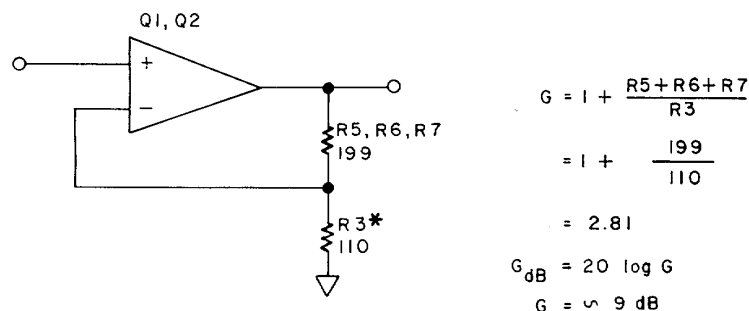

In the crystal mode (bandwidths <30 kHz), the amplifier includes Q3. The biasing of the amplifier is independent of its ac (21.4 MHz) operation but is very critical for its proper functioning. If a malfunction occurs, the dc bias should be checked first.

In the LC mode (the four wider bandwidths), the BW5 line goes to + 14.8V and turns off current source Q3. The current supplied by Q3 in the crystal mode is then supplied through CR1 and R13 from the BW5 line.

Unity Gain Buffer Amplifier

The unity gain buffer amplifier is the same as the 10 dB input buffer amplifier, except that it has a FET input (Q5) and is connected for unity gain. The input is selected by the BW5 line from CR9 in the LC mode, or from CR8 in the crystal mode.

In the crystal mode, the current through Q5 is determined by the difference between the current sourced by Q6 and that sunk by Q7: about 4 mA. A significant deviation from this current should be reflected by the gate-to-source voltage of Q5. The source should be at least 0.2V more positive than the gate, but not more than 1.5V more positive. If the difference is less than 0.2V, the FET current is too high; if the difference is greater than 1.5V, the FET current is too low. In either case the FET could also be defective. To determine

precisely the current through Q5, the difference between the current through R38 and that through R60 should be subtracted from the current through R30. If the results are inconsistent, check the above mentioned resistors.

In LC mode of operation, current is supplied through R37 and CR19 from the BW5 line instead of through Q6. The difference between the current through R37 and that through R30 yields the FET current.

Output Buffer Amplifier The output buffer amplifier is a complementary pair of transistors in which Q9 acts as a source follower boosted by Q10. The current through FET Q9 is set by R53:

$$I_{FET} = \frac{V_{be}(Q10)}{196\Omega} \approx \frac{.7V}{196\Omega} \approx 3 \text{ mA}$$

The total current through Q9 and Q10 is set by R54. The input is selected by the BW5 line from either CR16 in the LC mode or CR15 in the crystal mode.

Crystal Filtering Circuits

The bandwidths 1 kHz, 3 kHz, 10 kHz, and 30 kHz are obtained by crystal filtering. The crystals are used in series resonant mode and can be modeled as a series resonant circuit with a parallel capacitance:

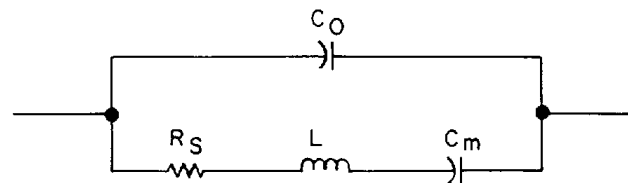

The parallel capacitance (Co) and series resistance (Rs) are not desired and are compensated for in the circuit, resulting in this simplified schematic of a single pole of crystal filtering:

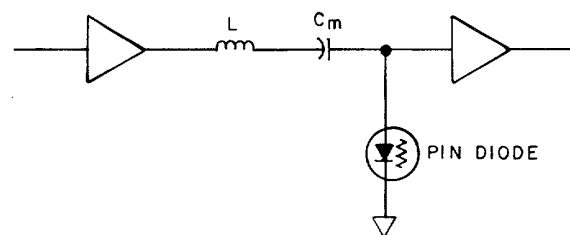

PIN diode CR4 functions as a variable resistor at 21.4 MHz. As the resistance is lowered by increasing the current in the BW6 line, the bandshape becomes narrower. The bandwidth of one pole widens to approximately 70 kHz when the PIN is turned off completely at the 30 kHz BW setting. (For a four-pole filter, the bandwidth of each pole is about 2.3 times the bandwidth of all four poles taken together. The bandwidth of two poles is about 1.5 times the bandwidth of all four poles taken together).

A simplified schematic of a crystal pole, including compensation for Rx and Co in the crystal and input capacitance of the buffer amplifier, is shown in Figure 8-27.

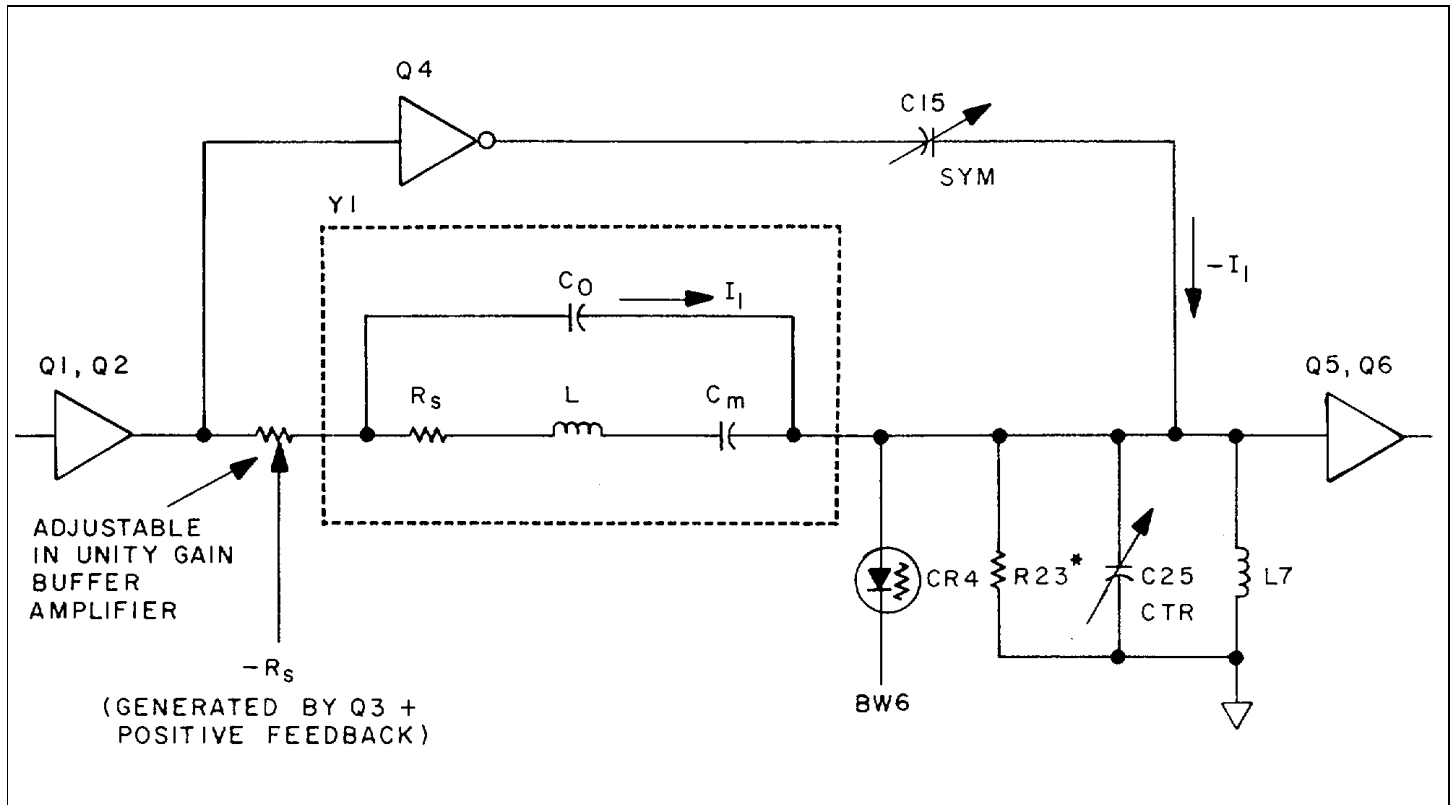

Figure 8-27. Crystal Pole, Simplified Schematic

The SYM adjustment, C15, compensates for C_o by producing a current ($-I_1$) that is equal to the current (I_1) through C_o of the crystal but opposite in phase. These currents cancel and nullify the effect of C_o . The positive feedback from the collector of Q3 generates a negative output resistance that cancels R_s of the crystal. This is approximated by resistor R6 in the 10 dB input buffer amplifier and by potentiometer R31 in the unity gain buffer amplifier.

The input capacitance of the buffer amplifier, the printed circuit board capacitance, the PIN capacitance, and the centering (CTR) capacitor C25 are in parallel resonance with L7. These components have negligible effect on the band shape and as long as C25 has sufficient range to 'dip' the bandshape, they can be ignored in analyzing the remainder of the circuit.

PIN diode CR4 controls bandwidths from 1 kHz to 10 kHz. For the 30 kHz bandwidth, CR4 is back biased, and R23 sets the bandwidth. If the 30 kHz bandwidth is much too narrow, even with CR4 back biased, the circuit may be loaded by a bad buffer amplifier (Q5, Q7) or inverting amplifier (Q4). If the bandwidth is only slightly narrow, it may be widened by padding R23. If the narrowest bandwidths (1 kHz or 3 kHz) have too little gain, and it cannot be increased enough by R31, either the crystals have too high a series resistance (defective crystal); or the output resistance is not negative enough (defective buffer amplifier or Q3).

Almost any defect in the Bandwidth Filter boards will result in a faulty dc bias condition in one of the three buffer amplifiers on each board. The dc bias of each stage is less straightforward than ac (21.4 MHz) operation and should be checked carefully.

LC Filtering Circuits

The two LC filtering circuits are used for the wider bandwidths (100 kHz through 3 MHz). They are similar in function; the first LC pole circuit is described. A schematic of the simplified equivalent circuit is shown below:

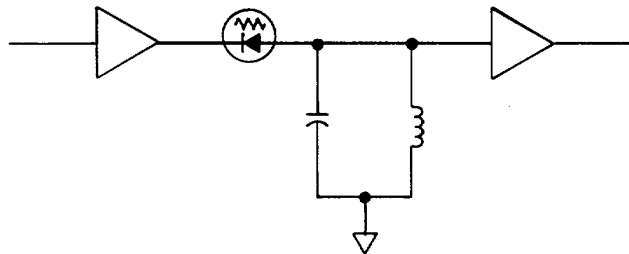

The LC filter uses a metallized inductor L6 in parallel with three capacitors: C23 (LC CTR) for centering, C21 for temperature compensation, and C20*. The parallel circuit is driven through PIN diode CR3, which functions as a variable resistor. The BW7 line sets the current through CR3. Higher resistance results in narrower bandwidth. A simplified schematic of the first LC pole circuit is shown in Figure 8-28.

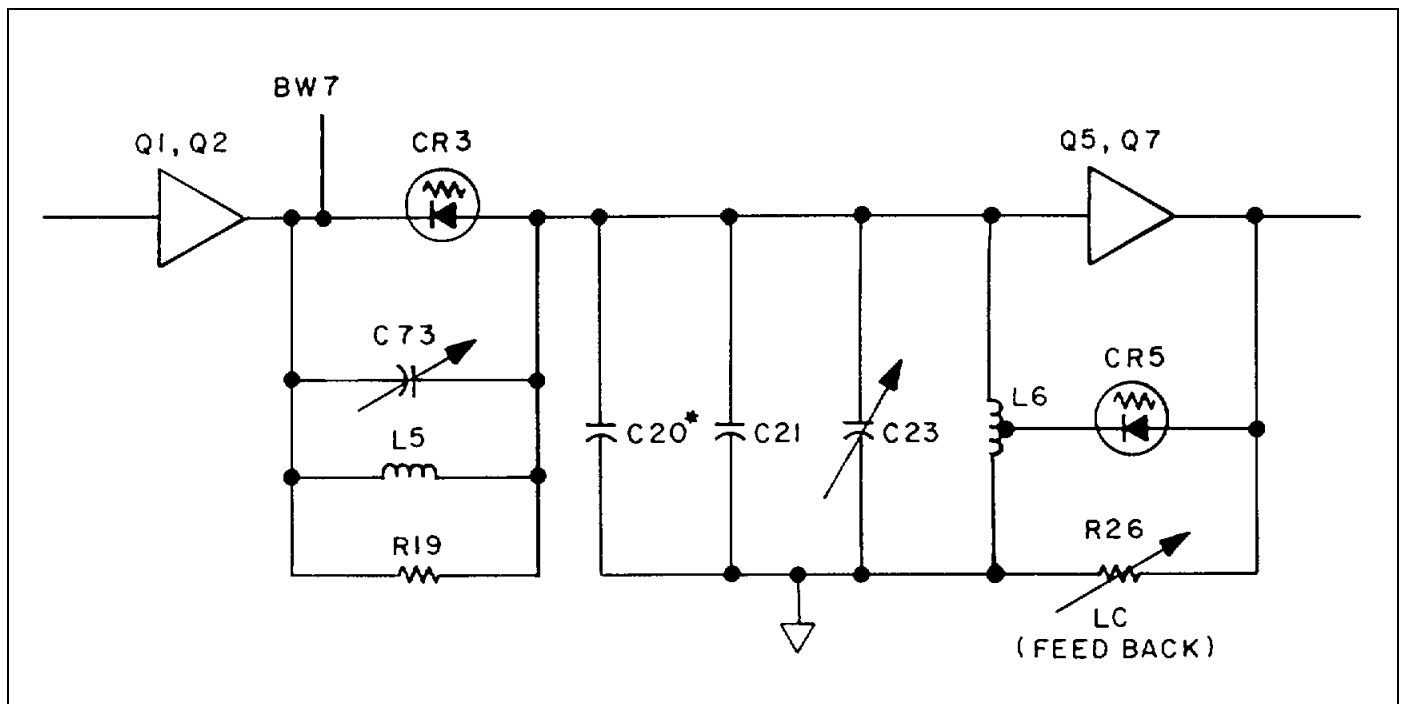

Figure 8-28. LC Pole, Simplified Schematic

C73 and L5 tune out the capacitance of CR3. R19 sets the 100 kHz bandwidth when CR3 is back biased (i.e., highest resistance). CR5 is controlled by the LC FEEDBACK pot R26 and compensates for losses in the parallel resonant circuit. (In the second LC pole circuit, fixed resistor R56* replaces CR5.) Low gain in one of the poles in the 100 kHz bandwidth is caused by:

1. The pole being centered at some frequency other than 21.4 MHz (a defective metallized inductor is most common).
2. The Q of the pole being too low (not a common failure).
3. Insufficient feedback from the buffer amplifier.
4. Defective buffer amplifier is loading the circuit.

If the 100 kHz bandwidth amplitude is correct, but that of the 300 kHz bandwidth is too low, either C73 or C74 might not be properly adjusted. If the 300 kHz amplitude is too high, the four LC poles are not tuned close enough to the same frequency. In either case, refer to Section V, Adjustments.

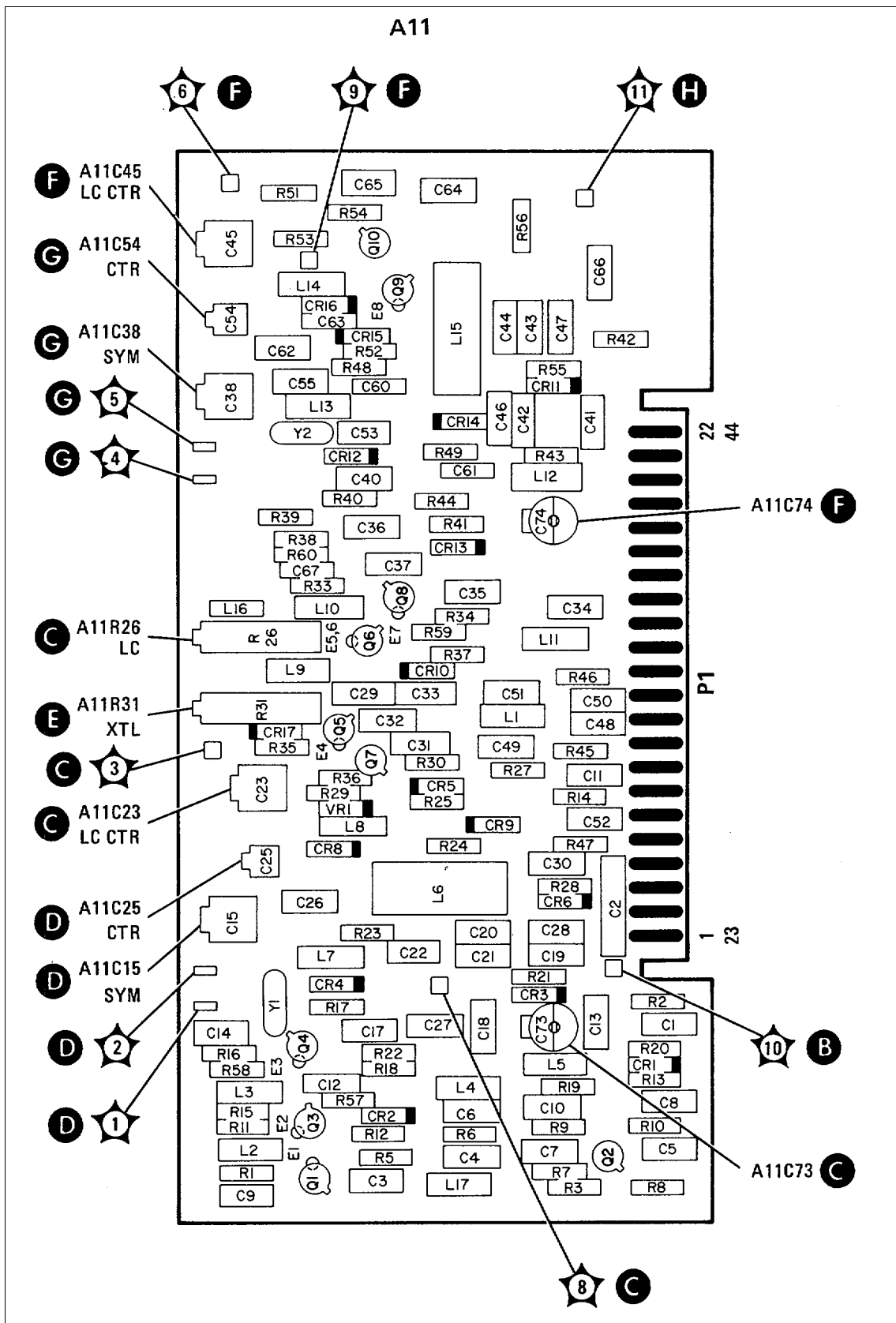

Figure 8-29. A11 Bandwidth Filter No. 1 Assembly, Component and Test Point Locations

THIS PAGE MISSING NOT AVAILABLE FOR DIGITIZATION.

PAGES
8-69

A12 STEP GAIN CIRCUIT DESCRIPTION

General Description

The Step Gain Assembly contains three amplifier stages to provide a 0 to 50 dB amplification of the 21.4 MHz third IF signal. The amplifier stages are selected by front panel REF LEVEL dBm switch A2S1. At the output of the final amplifier is a two-section bandpass filter. In conjunction with the front panel REF LEVEL FINE control, the step gain assembly also contains the circuitry for the 0 to 12 dB fine control for the reference level. A TEST/NORM switch is available; in TEST position, tests are made at a low gain level.

0 - 12 dB Control

A minimum current flow through PIN diode A12CR3 (maximum allowable diode resistance) is established by the 12 dB potentiometer, A12R6, so the diode is never completely cutoff. Adjustment of A12R6 sets the 0.3 dB point and is adjusted with the REF LEVEL FINE control fully clockwise (-12 position).

The maximum current flow through the PIN diode is set by the 0 dB potentiometer, A12R5. A12R5 is adjusted to the 12.3 dB attenuation point with the REF LEVEL FINE control fully counterclockwise (0 position).

Transistors A12Q8 and A12Q9 are identical current sources. The maximum current is set by 0 dB adjustment A12R5 in the common base circuit. Diode A12CR1 provides temperature compensation for the transistors.

A12Q8 provides current for a bias voltage applied to the anode of the PIN diode. The voltage source consists of A12R6, A12R17, and A12CR2. Diode A12CR2 provides temperature compensation for the PIN diode. Inductance A12L5 isolates the current source from the RF signal.

A12Q9 provides current for a variable voltage source at the cathode of PIN diode A12CR3. A resistance is formed by REF LEVEL FINE control R4 (shown on A2 schematic) and fixed resistor A12R9. The fixed 316K ohm resistor is used to shape the value of potentiometer R4 to match the PIN diode resistance changes. The REF LEVEL FINE control varies the voltage at the cathode of PIN diode A12CR3 and thus varies diode current flow. Regulating the current flow through the PIN diode controls the amount of signal attenuation. For example, if PIN diode current flow is increased, more RF signal is shunted or bypassed to ground. A12C12 provides the RF ground and also isolates from ground the variable dc from the REF LEVEL FINE control. When the REF LEVEL FINE control is fully clockwise, the PIN diode is at minimum conduction, and maximum signal is applied to the base of A12Q7. Conversely, when the REF LEVEL FINE control is fully counterclockwise, the PIN diode is at maximum conduction and minimum signal is applied to A12Q7.

Step Gain Amplifiers

Buffer amplifier A12Q7 operates in an emitter-follower configuration and provides isolation between the 0 12 dB control and the 10 dB amplifier.

The three step gain amplifiers can be considered as operational amplifiers. An equivalent circuit for the three stages is shown in Figure 8-31. The gain for each amplifier is $A_v = R_f/R_i$. The feedback resistance (R_f) for the 10 dB amplifier is A12R26, 562 ohms; and for the 20 dB amplifiers it is A12R32 and A12R38, 750 ohms. The input resistance R_i is a combination of a fixed series resistance (56.2 ohms) and the controlled resistance of the PIN diodes. The resistance of the PIN diodes is approximately 10 to 1000 ohms and increases as the forward bias current is decreased from 100 mA to 1 μ A. R_i is approximately 260 ohms for the 10 dB amplifier and approximately 83 ohms for the 20 dB amplifiers.

Selection of the correct combination of step gain amplifiers is accomplished with front panel REF LEVEL dBm switch A2S 1. Rotating the switch grounds the emitter circuit of the selected amplifier(s) allowing current to flow through the PIN diode(s). The possible switch combinations allow the gain to vary from unity (all switches open) to 50 dB maximum gain with all three emitter circuits grounded.

A TEST/NORM switch, A12S1, is included in the emitter paths of the 20 dB step gain amplifiers. In the TEST position, the switch defeats the two 20 dB amplifier stages, providing a fixed 10 dB of gain for use when making LOG amplifier adjustments.

Bandpass Filter

The output of the step-gain amplifiers is coupled through a two-section bandpass filter. The bandpass filter consists of A12L9, A12L10, A12C24, and A12C25 and provides rejection of signals outside the region of 21.4 MHz.

+ 19.5V Regulator

The + 19.5V regulator consists of series regulator A12Q13, driver A12Q12, and reference amplifier A12Q10 and Q11. Zener diode A12VR1 provides a +6.2V reference for the base of Q11. Q10 senses the + 19.5V output across resistors A12R45, R46, and R7, the + 19.5V adjustment. Should the output voltage start to drop below + 19.5V, Q10 will start to turn off. This will turn on Q11 which turns on Q12 and Q13, raising the output back to + 19.5V. L11 and C27 filter the + 19.5V output. C26 between the collector and emitter of Q 12 is used to stabilize the feedback gain at high frequencies.

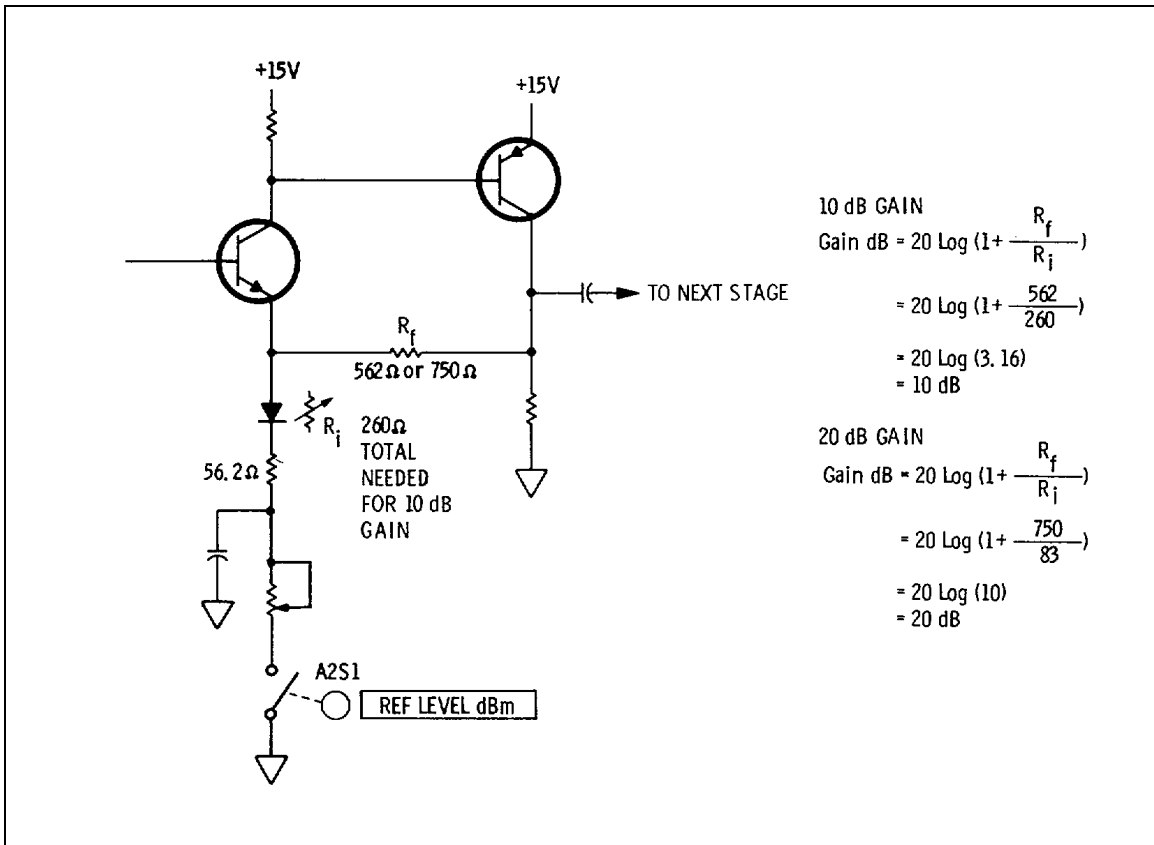

Figure 8-31. Equivalent Circuit for Step Gain Amplifiers

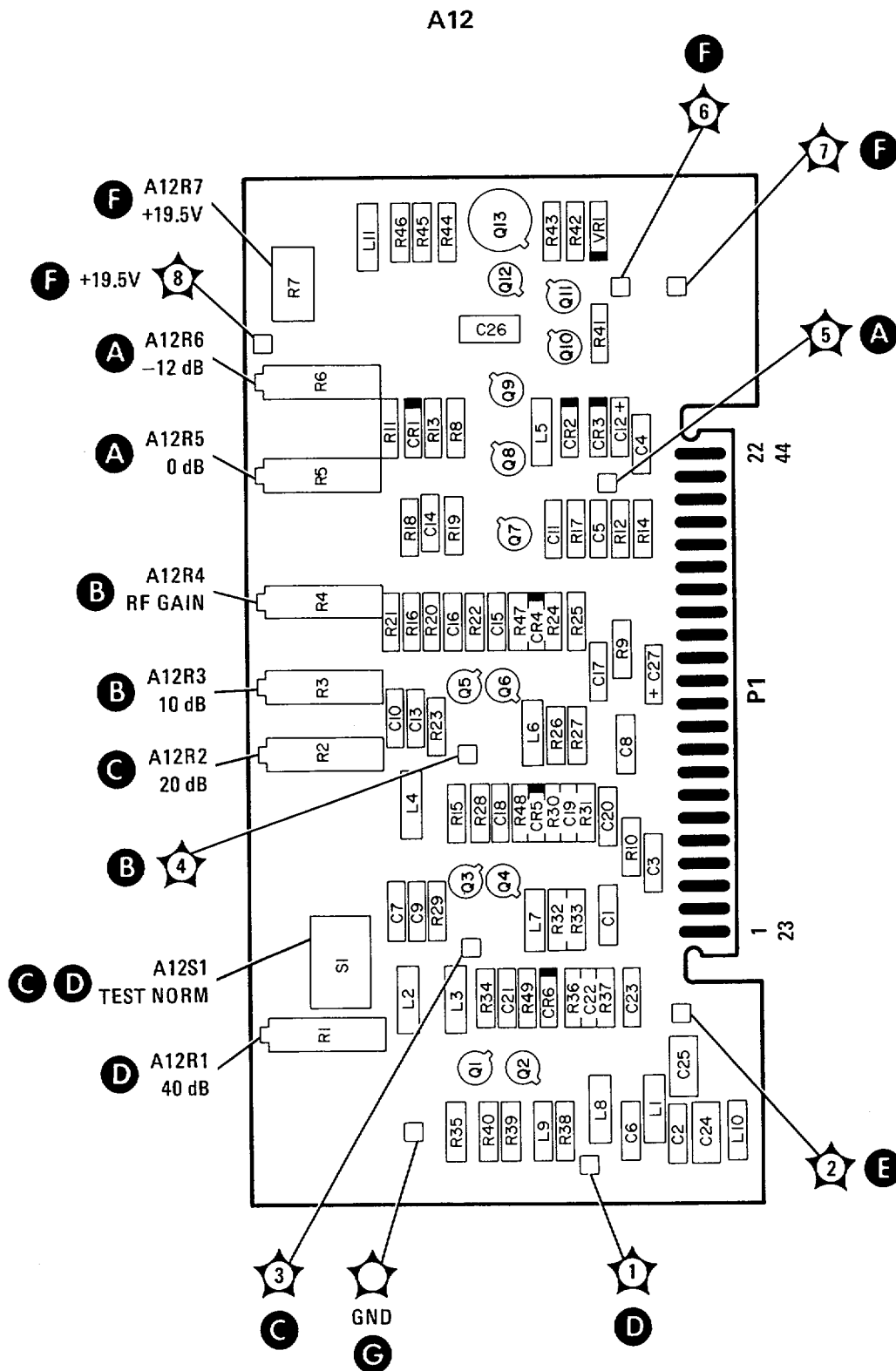

Figure 8-32. A12 Step Gain Assembly, Component and Test Point Locations

THIS PAGE MISSING NOT AVAILABLE FOR DIGITIZATION.

PAGES
8-75 through 8-76

A13 BANDWIDTH FILTER NO. 2 CIRCUIT DESCRIPTION

The Bandwidth Filter No. 2 Assembly is very similar to the Bandwidth Filter No. 1 Assembly A11, and corresponding components have the same reference designators. The differences between the two board assemblies are as follows:

1. A13 has a limiting diode, CR18, connected between the input (P1-23) and ground; A11 does not.
2. The values of some resistors and capacitors in A13 are different from their counterparts in A11.
3. A13 has about 0.5 dB less gain than A11.

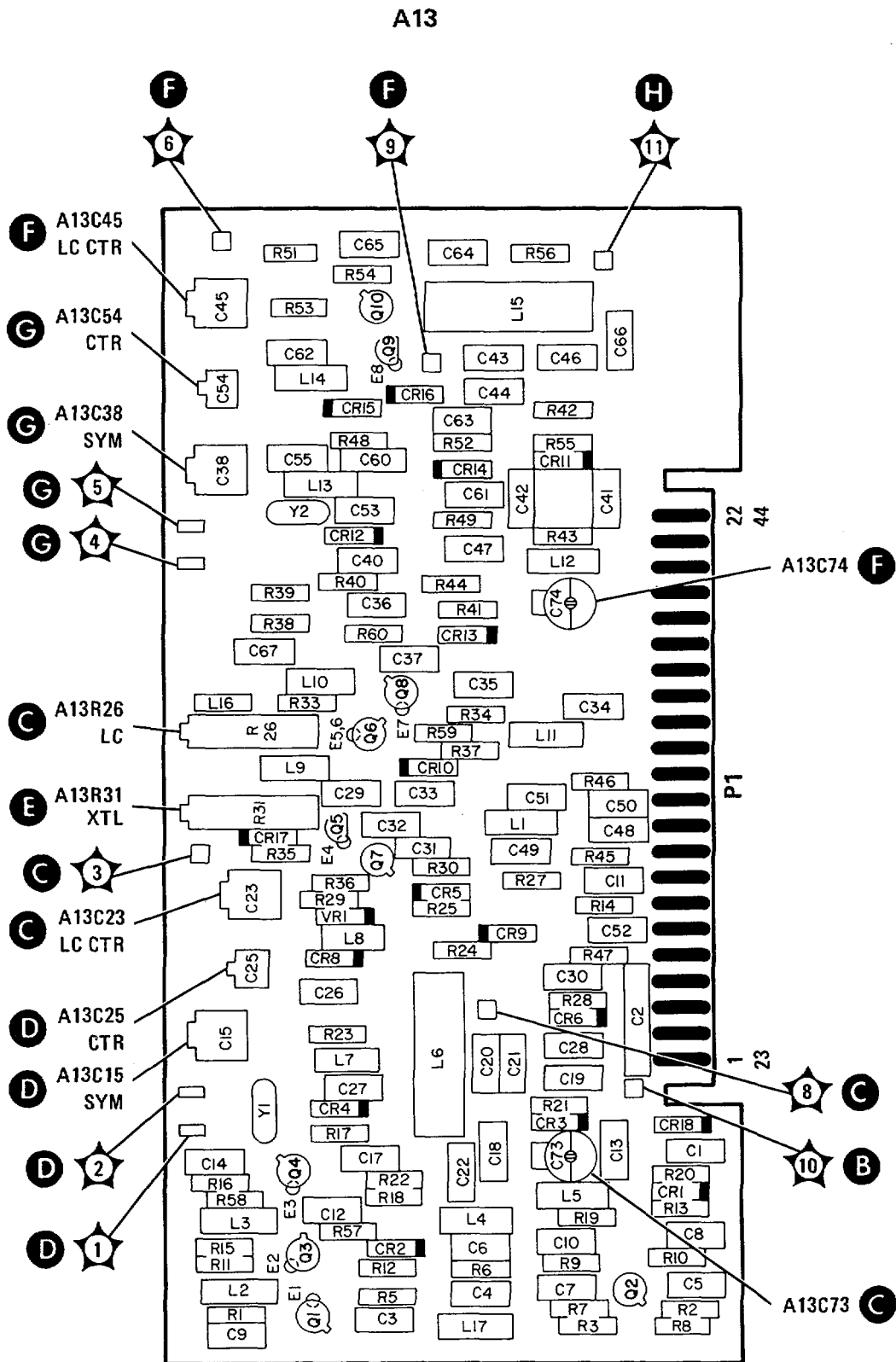

Figure 8-34. A13 Bandwidth Filter No. 2 Assembly, Component and Test Point Locations

THIS PAGE MISSING NOT AVAILABLE FOR DIGITIZATION.

**PAGES
8-79 through 8-80**

A14 LOG AMPLIFIER ASSEMBLY, CIRCUIT DESCRIPTION

General Description

The Log Amplifier Assembly provides the ability to display signals in either a linear mode or 70 dB LOG mode. It also operates with the Step Gain Assembly A12 to provide the last 40 dB of step gain amplification of the 21.4 MHz IF signal.

The Log Amplifier Assembly has seven amplifier stages, with each stage capable of providing both linear and logarithmic amplification. Following the amplifier stages, the amplified IF signal is detected to produce the vertical signal for the display. An offset circuit, following the detector, is used in the log mode to offset the vertical output in steps equivalent to 40 dB of IF gain.

Log Mode of Operation

The seven amplifier stages limit the gain in sequence to provide 70 dB of log amplification. Each stage consists of an emitter follower used as a voltage source to drive a common-base amplifier whose gain decreases with increasing signal level.

Log Amplifier Gain. The operation of the second stage is described. In the log mode of operation, Q24 (Gain Control Lines circuit) is on, forward biasing the log diodes, CR10 and CR11, which are Schottky diodes with a forward bias voltage of approximately 0.4V. The gain of the amplifier is set by the ratio of R52 to the total resistance RT between the emitters of Q13 and Q8. An example of gain computation is shown in Figure 8-36 RT is at a minimum (approximately 150 ohms) for small signals when the ac signal current in log diodes CR10 and CR11 is small compared to their dc bias current. As the ac signal level is increased, the ac signal current increases to the level of the dc bias current and RT increases because of current limiting in the diodes.

The initial (maximum) gain of the stage (approximately 10 dB) is set by the dc bias current through the log diodes. The bias current is controlled by the temperature variable -8VT supply at the emitter of Q24. The final (minimum) gain of the stage (0 dB) is set by the circuit configuration (RT becomes very large) and can be set further by the adjustment of R39 - 10 dB.

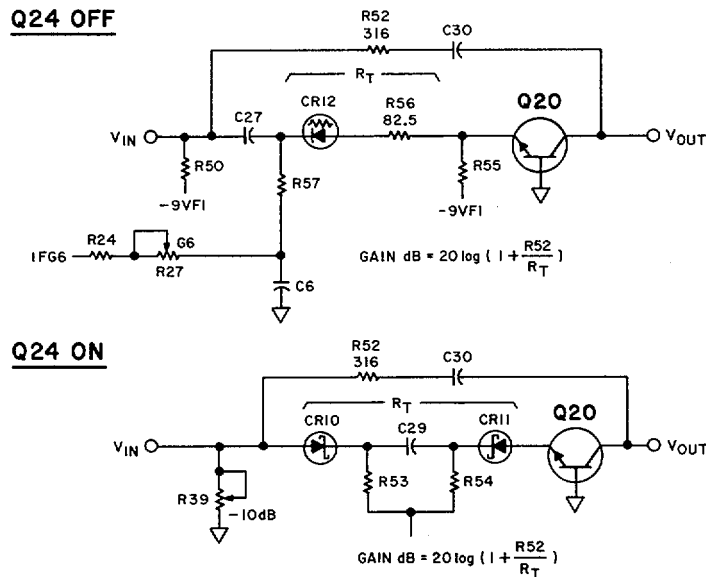

Figure 8-36. Simplified Log Amplifier Stage

Linear Mode of Operation

Linear Gain. In the linear mode, the limiting action of the log diodes is removed from the seven amplifier stages. The operation of the second stage is described. Q24 is turned off, and the dc bias current through log diodes CR10 and CR11 is zero. With zero dc bias current the total resistance, R_T , is maximum and the stage gain is approximately unity (0 dB). (See Figure 8-26.)

In the sixth and seventh stages, an alternate signal path is used to set the gain at about 5 dB per stage. The purpose of this fixed gain is to scale properly between the log and linear modes. These stages are activated by the -8VT from the AMPLITUDE SCALE switch through R34 (LIN), R93, and R101, and finally through the cathodes of CR25 and CR28. The combined gain of the two stages is adjusted with R34 (LIN), which controls the dc bias current in the PIN diodes.

Step Gain Operation

The Log Amplifier Board Assembly provides 40 dB of step gain in 10 dB steps. This gain, combined with 50 dB of step gain from Step Gain Assembly A12, will produce up to 90 dB of total step gain. The amount of step gain is selected by the front panel REFERENCE LEVEL switch (A2A1S1). The control lines from A2AiS1, IFG4, IFG5, and IFG6, control the step gain on the Log Amplifier Board Assembly.

Step Gain When in Log Mode. When in log mode, control lines IFG4, IFG5, and IFG6 route + 15V to the Log Offset circuit through R24, R25, and R26. This forward biases diodes CR32, CR33, and CR31. The Log Offset circuit provide 10, 20, 30, or 40 dB of step gain, depending on the state of the control lines. (See Log Offset circuit description.)

Step Gain When in Linear Mode. In linear mode, amplifier stages 2, 3, 4, and 5, are used to provide 40 dB of step gain in 10 dB steps. In linear mode, the LOG/LIN line is at -8VT, Q24 is off, and the log diodes are normally off. Each amplifier stage has unity gain (0 dB). The control lines, IFG4, IFG5, and IFG6 are used to forward bias the log diodes, thus changing the gain of the amplifier stages from 0 dB to 10 dB. The state of the control lines determine which of stages 2, 3, 4, or 5 has a gain of 10 dB.

For example, with INPUT ATTEN at 0 dB and REFERENCE LEVEL dBm at -60, -8VT is routed through A2A1S2 and A2A1S1 to the IFG4 control line to forward bias CR22. The fifth amplifier stage gain changes from 0 dB to 10 dB, providing 10 dB of step gain.

Resistors R33, R30, and R27 may be adjusted to set the step gains of stages 5, 4, and 3 and 2, respectively.

Log Mode Temperature Controlled Variable Gain Amplifier

LOG/LIN Relationship. In linear mode, when approximately 700 mVrms (+ 10 dBm) is applied to the input of the log amplifier, the voltage at the output of stage 7 (TP5) is about 1.5 Vrms. With the same input signal in log mode, the output at TP5 is about 2.0 Vrms. To maintain equal relationship with maximum input signal (trace at the top of the display) the output in log mode must be attenuated. This attenuation is achieved through the use of variable gain amplifier Q7, whose gain is determined by the ratio of its collector load to its emitter load.

Variable Gain Amplifier. In linear mode, the LOG/LIN control line is at -8VT. This forward biases CR4 and causes the output of U2B (TP1) to go to approximately + 15V. CR29 is reverse biased, and the gain of the variable gain amplifier is R104/R105 (100/316), or approximately 0.3. In log mode, the LOG/LIN control line is at + 15V, which reverse biases CR4. The output of U2B is now approximately + 0.45V. CR29 is forward biased and has an ac resistance of about 100 ohms, which is in parallel with the 100-ohm R104, so the collector load of Q7 is 50 ohms. The gain is 50/316, or 0.15. This gain depends upon the resistance of CR29, which is set by SLOPE adjustment R23.

Detector and Buffer Amplifier

The signal output of Q7 is applied to the base of Q6, which converts voltage variations into current variations. Q5 is the current driver for the detector. Q4, a half-wave rectifier, is biased just below cutoff by CR1. When the input signal is positive, Q4 is in conduction but is cut off during the negative transistion. The detector output is routed to a low-pass filter and a X2 buffer amplifier, Q21 and Q22, to provide the video output.

Log Offset

The last 40 dB of log step gain is produced in this circuit. When this gain is used, there is already a full 50 dB of gain in the Step Gain Assembly, so the noise of the analyzer is amplified into the log range of the Log Amplifier Assembly. This makes further amplification unnecessary since any signal below the log range of the Log Amplifier Assembly would be buried in the noise. The output of the detector can then be offset in 100-mV steps corresponding to 10 dB of IF amplification. This offset is provided by Q23 operating as a stepped current source into R115. With the AMPLITUDE SCALE switch in one of the LOG/DIV positions, + 15V is routed through the closed contacts of the REFERENCE LEVEL dBm switch to the IF gain control lines IFG4, IFG5, and IFG6. With an IF gain control line connected to + 15V, a log-shift diode (CR31, CR32, or CR33) is forward biased, and this bias current, determined by R123, R124, or R125, flows into the emitter of current source Q23. IFG4 and IFG5 each provides 10 dB (100 mV) of log offset gain and IFG6 provides 20 dB (200 mV). The LOG GAIN adjustment R121 sets the operating point of Q23 for 100-mV steps.

Temperature Compensation Power Supply

Temperature compensation is provided for the - 8VT and + 1V regulators. CR2 and CR4 operate as the temperature-sensing element. Temperature variations cause diode voltage changes that are amplified by U1A for the - 8VT supply and by U2B for the + 1V supply. The - 8VT supply provides bias current for the Schottky diodes in the LOG mode. In the linear mode, the - 8VT supply provides bias current for CR12, CR15, CR19, CR22, CR25, and CR28. The + 1V supply provides bias current for CR29.

+11 V Regulated Power Supply

A precise 5.4V reference voltage VR1 is provided for the + 11V Regulator. This reference voltage is applied to the positive input of U1B. R5 and R6 set the gain of U1B to 2.1. The output at TP2 is 2.1×5.4 , or 11.3V. Q1 acts as an emitter follower and provides the current drive for the + 11 V supply.

A14

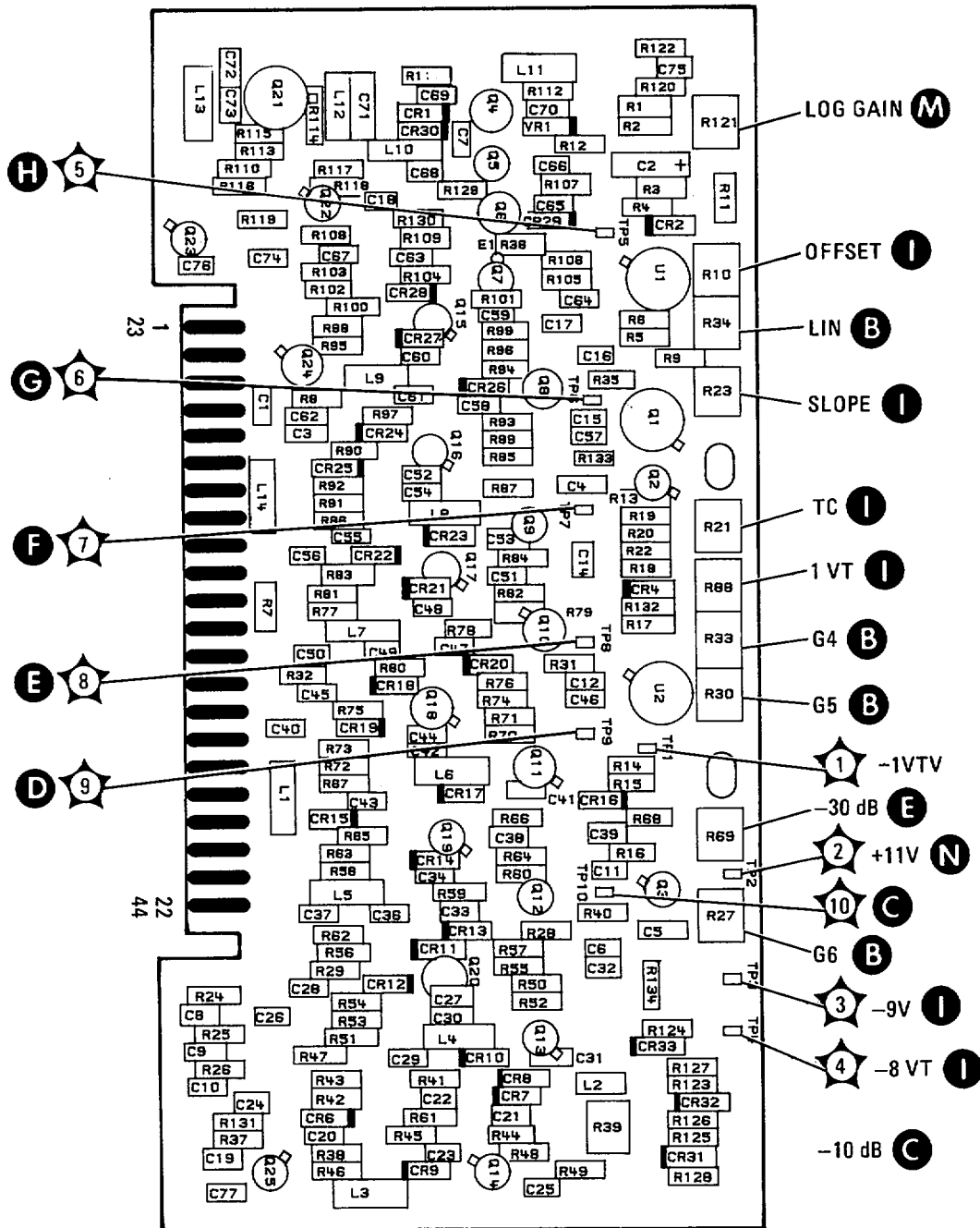

Figure 8-37. A14 Log Amplifier Assembly, Component Locations

THIS PAGE MISSING NOT AVAILABLE FOR DIGITIZATION.

**PAGES
8-85 through 8-88**

A15 VERTICAL DRIVER AND BLANKING CIRCUIT DESCRIPTION

General Description

The Vertical Driver and Blanking Assembly provides a preamplifier circuit to amplify the detected and filtered video from the log amplifier. The video signal needed to trigger the sweep generator in INT mode is picked off at the preamplifier. A vertical driver (differential amplifier) converts the signal to drive the vertical deflection plates (push-pull output).

The blanking and pen lift drive signals are also generated on assembly A15.

Preamplifier

The detected and filtered video input (0V to 0.8V) from the Log Amplifier Assembly A14 is applied to the gate of A15Q17A. A15Q17, Q11, Q12, and Q18 make up a differential amplifier. The gate of Q17A is the noninverting input and the gate of Q17B is the inverting input. The output at the emitter of A15Q18 is feedback applied to the gate of Q17B through voltage divider A15R11, R12, and R13. The voltage gain of the preamplifier is $1 + R11/R12 + R13 = 10$. With an input voltage range of 0V to 0.8V, the maximum signal measured at the output of A15Q18 (TP5) would be 8V. (This signal coupled through A15R17 is the trigger voltage for INT mode.) A buffer amplifier consisting of A15U2A, U2B, and Q20 provides isolation between the preamplifier and vertical driver. A15U2D and Q13 are current sources to bias the differential amplifier.

The vertical deflection sensitivity of the following vertical driver is 0.8V for full-scale deflection. Since a maximum possible signal of 8V is available from the preamplifier, to obtain the correct signal amplitude, a divide-by-10 and an offset circuit are used.

10 dB/DIV and LIN. The preamplifier output is divided by 10 when LOG/LIN switch A2S2 is in either LIN or 10 dB/DIV. With LIN or 10 dB/DIV selected, + 15V is applied to the Expand line, back biasing A15CR1, and turning A15Q19 on. Also A15CR2 is on and CR3 is back biased. With A15Q19 on, a voltage divider consisting of A15R18, R20, and Q19 divides the preamplifier output by 10.

1 dB/DIV. With 1 dB/DIV selected, the Expand line is open and A15Q19 is held off by A15CR1 and R22. The divide-by-10 circuit is disabled and the full 8-volt preamp voltage is available. Since only the 0.8V peak can be displayed, the signal to the buffer amplifier is offset by -7.2 volts as follows: A current source A15U2C is on, drawing current through A15CR3 and R18. The voltage drop across R18 is set for 7.2V, so the 8V input is shifted -7.2V below ground. When the signal goes below ground (OV), A15CR4 conducts and clamps the signal at -0.6V. The 1 dB OFFSET adjustment, A15R1, sets the current for the correct voltage shift.

-5.5V Temperature Compensated Supply

The -5.5V temperature-compensated supply controls four current sources: A15U2D, Q13, U2C, and Q15. The temperature-sensing element, A15U2E (connected as a diode), tracks the base-emitter temperature changes of the current-source transistors.

Vertical Driver

The vertical driver-is a differential amplifier that consists of A15Q2, Q3, Q6, Q7, and Q14 with Q15 as the current source. (See Figure 8-39.) The 0V to 0.8V vertical signal from the output of the preamplifier is converted to a push-pull signal to drive the CRT vertical deflection plates. A15Q14 is a dual transistor used as the input stage to the Vertical Driver circuit. The reference input level at the base of A15Q14A is set by the VERT POSN control, A2R6. The gain of the vertical driver is set by the voltage divider consisting of A15R34, R42, and VERT GAIN control A2R7. The transistor pairs A15Q2/Q6 and A15Q3/Q7 are current-to-voltage amplifiers and are driven by the current from the collectors of A15Q14A and B respectively. Diodes A15CR5 through CR8 protect the bases of A15Q2, Q3, Q6, and Q7 to prevent them from

being driven more negative than approximately 0.6V (the voltage drop across a diode). The resistors A15R44 and R52 decouple the capacitive load of the CRT plates from the emitters of A15Q2 and Q3, preventing overshoot and ringing in the vertical driver. A15Q21, CR11, and CR12 provide vertical driver input switching for normalizer compatibility. When the normalizer is not connected, pull-up resistor A15R56 places the cathode of A15CR11 at + 15V, preventing CR11 from conducting. A15Q21 is turned on so the input to the vertical driver is from the output of the preamplifier. When the normalizer is connected and in the BYPASS mode, the L NORM line at A15J3 is high (+ 12V) preventing A15CR11 from conducting. When the normalizer is operating, the L NORM line is pulled low (- 12V) causing A15CR11 to conduct. A15Q21 is turned off by the negative voltage at the gate, switching the vertical driver input to the normalizer output (Y NORM).

Blanking OR

Normally A15Q4 is off placing a low at the base of A15Q9 and turning it on. A15Q4 requires a positive voltage of about 1 mA to turn on and cut Q9 off. A high into the OR circuit provides a high blanking output (0V) to the mainframe. There are four conditions that cause blanking of the sweep. (See Figure 8-40.) When the normalizer is not connected, pull-up resistor A15R56 places the cathode of A15CR12 at + 15V, preventing CR12 from conducting. When the normalizer is connected and in the bypass mode, the L NORM line at A15J3 is high (+12V) keeping A15CR12 from conducting. When the normalizer is operating, the L NORM line is pulled low (-12V) causing A15CR12 to conduct. With A15CR12 conducting, the output of the blanking OR is held at a negative voltage level, inhibiting blanking from the 8558B.

Vertical/Baseline Comparator

The vertical/baseline comparator circuit consists of A15Q16 and Q8. The baseline clipping reference voltage is set by front panel BASELINE CLIPPER control A2R2 which varies the base voltage of A15Q16. The vertical preamplifier output signal is applied to the base of A15Q8. The signal voltage at the base of A15Q8 is compared to the dc reference on Q16. When the signal voltage becomes more negative than the reference, Q8 turns on and the high input to its base turns A15Q4 on, blanking the display.

Sweep Ramp High/Low Limit Comparator

Operational amplifier A15Q1A and Q1B is connected to form a comparator circuit. A voltage divider made up of A15R6, R7, and R8 establishes a high and low voltage reference at U1A pin 2 and U1B pin 5. The switching limits are approximately + 0.6V at U1B pin 5 (low frequency blanking) and +6.8V at U1A pin 2 (high frequency blanking). The signal to the other inputs of the comparator is the frequency analog voltage from the YIG main coil swept driver. The frequency analog input voltage is proportional to the instantaneous frequency to which the analyzer is tuned and sweeps from 0.7V to 6.7V as the analyzer tunes from 0 to 1500 MHz. If the YIG tuning voltage at U1B pin 6 goes below 0.6V, the output of U1B rises to about + 14V. This turns on A15Q4 and blanks the display. If the YIG tuning voltage at U1A pin 2 rises above 6.8V, the output of U1A rises to about + 14V turning on A15Q4. Blanking of the display occurs whenever the analyzer is swept below about - 30 MHz or above about 1600 MHz.

Pen Lift Driver

The display is blanked during retrace and the dead time of the sweep voltage. The Retrace Blanking input from A8Q9 in the sweep generator circuit is applied to the emitter of buffer amplifier A15Q1. When the sweep ramp is turned off (dead time), the Retrace Blanking signal rises to + 10V. The + 10V connected to the base of A15Q4 produces the blanking output. The same + 10V Retrace Blanking input is applied to the base of A15Q5, turning Q5 on and Q10 off. The collector of A15Q10 then rises to + 15V. A15Q10 provides a signal that can be used to drive the Pen Lift input on an X-Y recorder. This signal causes the pen to lift during the analyzer sweep retrace and dead time. Breakdown diodes A15VR2 and VR3 suppress the high positive and negative voltage transients that some X-Y recorder pen lift coils can generate.

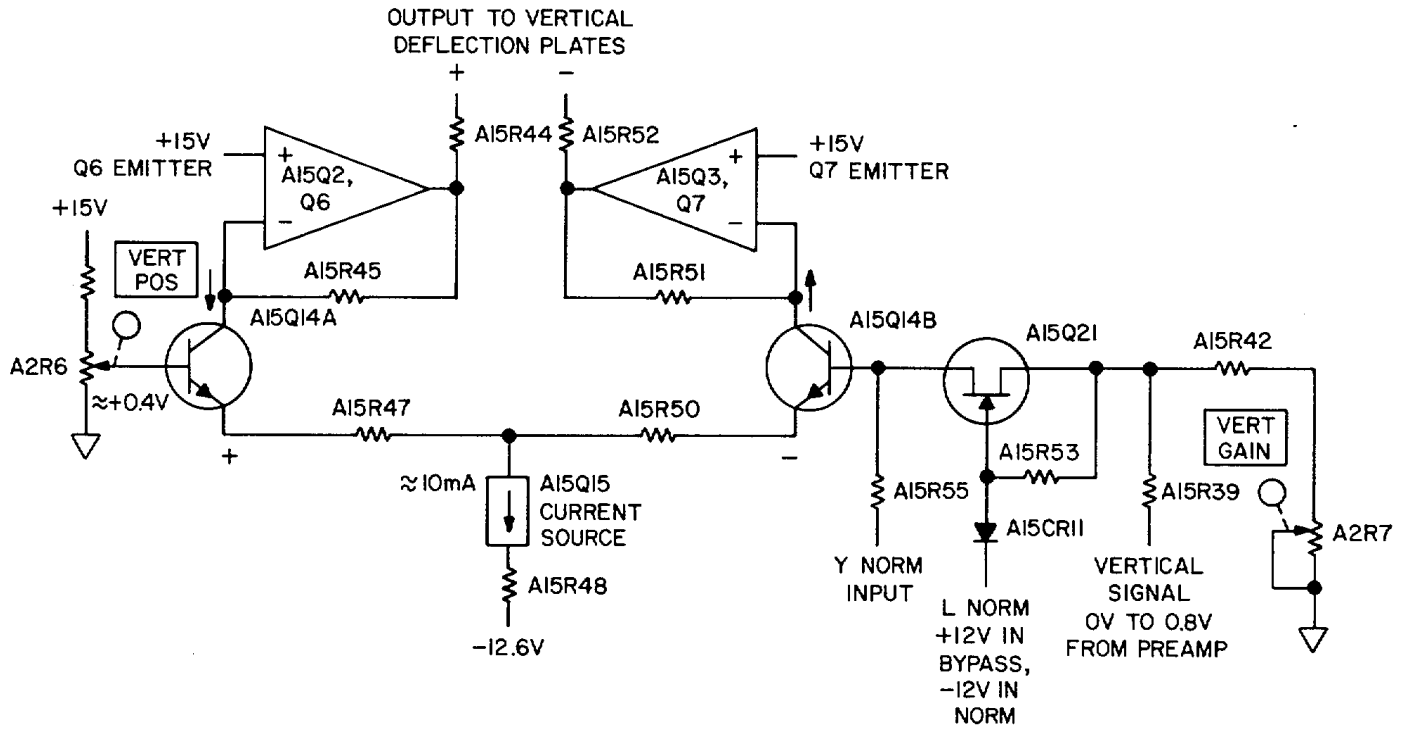

Figure 8-39. Simplified Vertical Driver Circuit

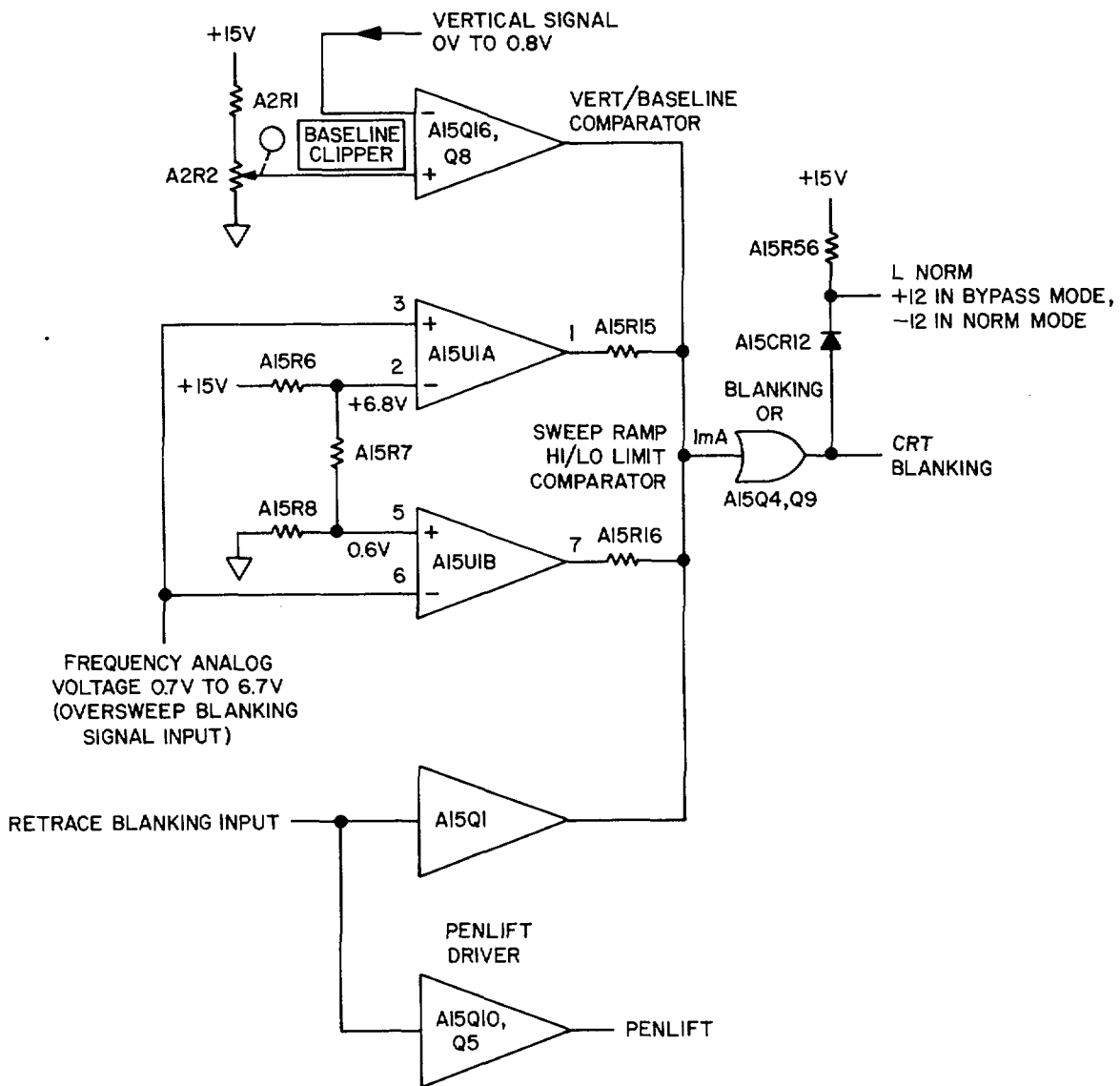

Figure 8-40. Simplified Blanking Circuit

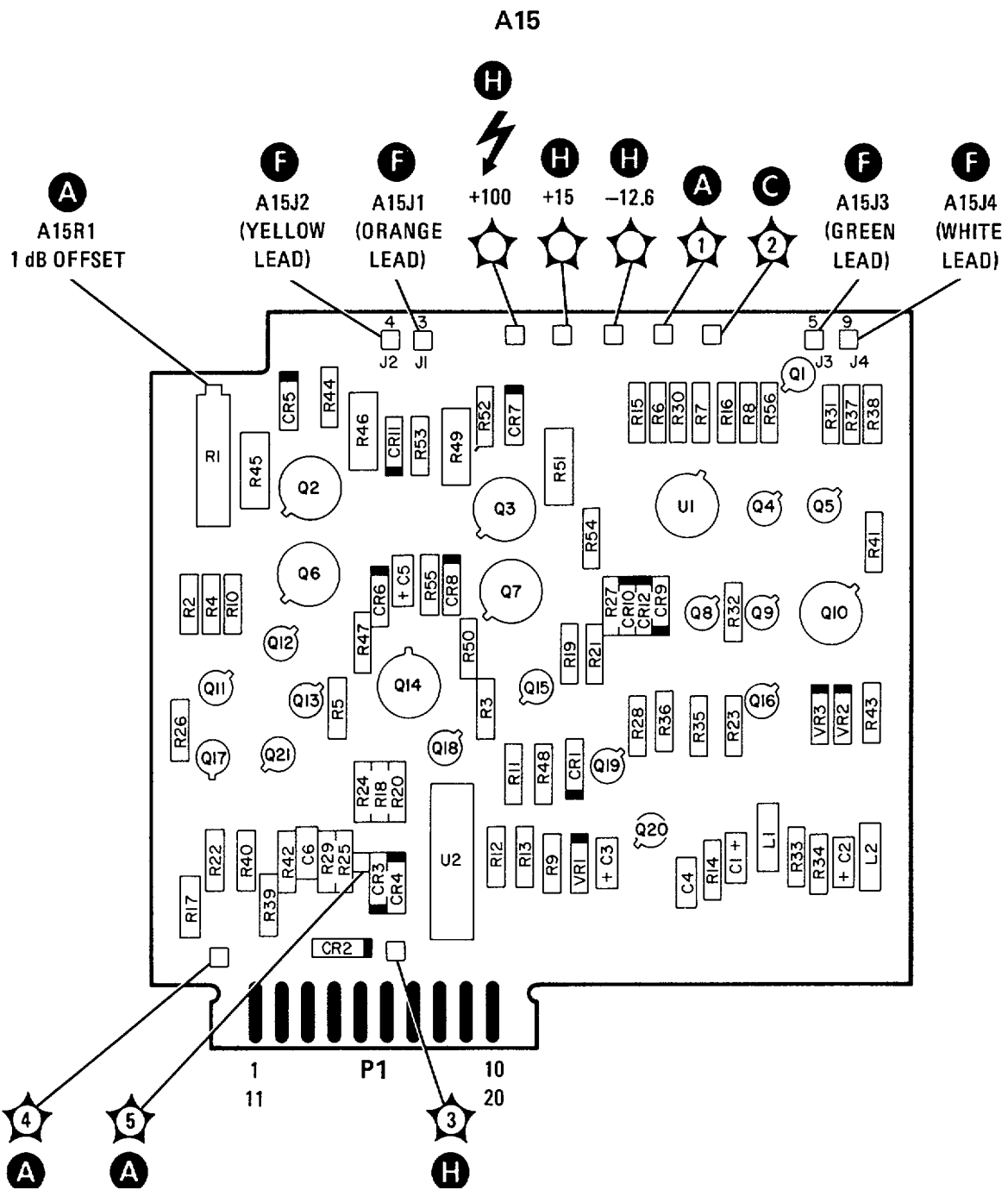

Figure 8-41. A15 Vertical Driver and Blanking Assembly, Component and Test Point Locations

THIS PAGE MISSING NOT AVAILABLE FOR DIGITIZATION.

**PAGES
8-95 through 8-100**

A17 INVERTER CIRCUIT DESCRIPTION**+5V Power Supply**

Inverter Assembly A17 is a single transformer inverter with A17Q1 and Q2 operating as a 22 kHz squarewave oscillator. Diodes A17CR1 and CR2 prevent the transistors from base-emitter reverse breakdown. Positive feedback to sustain the oscillation is taken from the transistor base tickler winding of T1. A17R1* provides current to the base of Q2 to start oscillations when the -12.6V supply is first turned on. The voltage at the collectors of A17Q1 and Q2 is a -12V to +12V square wave. Diodes A17CR5, CR6, CR7, and CR8 are connected as a full-wave rectifier, receiving ac power from 6V taps on either side of the grounded center tap. The rectified dc is filtered by A17L6, L7, L8, C5, and C6. The filtered output voltage is +5V and powers DPM Driver Assembly A1A2. A17VR1, a 6.19V zener, provides protection for the DPM Driver in case of excessive or reverse voltage.

+20.5V Power Supply

The oscillating current between the collectors of A17Q1 and Q2 through the primary winding of T1 induces a voltage in the secondary of T1. Diodes CR3 and CR4 full-wave rectify this voltage, which is then filtered by A17L3, L4, L5, C3, and C4. The dc output voltage, approximately +5.5V, is added to the +15V supply to obtain a + 20.5V supply

A17

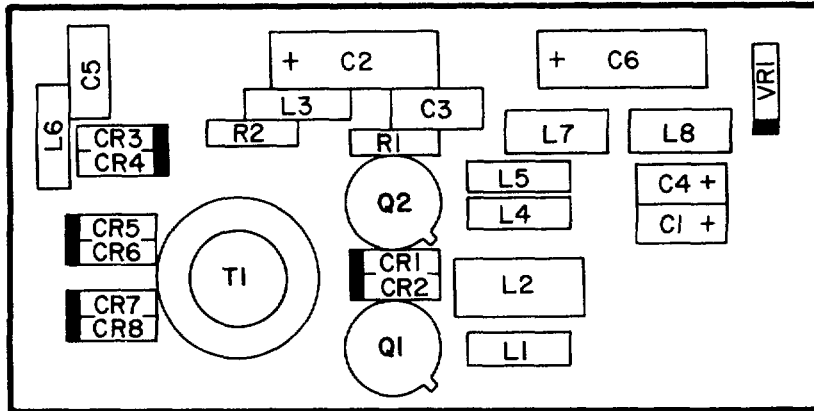

Figure 8-45. A17 Inverter Assembly, Component Locations

THIS PAGE MISSING NOT AVAILABLE FOR DIGITIZATION.

**PAGES
8-103 through 8-106**

FRONT SWITCH ASSEMBLY A2 DISASSEMBLY AND REPAIR

Tools and Materials Required

Description	HP Part Number	Check Digit
No. 2 Spline (Bristol) Wrench	8710-0055	0
Long No.4 Hex (Allen) Wrench	5020-0288	5
Long No. 6 Hex (Allen) Wrench	5020-0289	6
13/64-inch Open-end Wrench	8710-0946	8
5/16-inch Open-end Wrench	8720-0015	3
3/8-inch Open-end Wrench	8720-0016	4
1/2-inch Open-end Wrench	8720-0025	5
5/8-inch Open-end Wrench	8720-0010	8
1/4-inch Nut Driver	8720-0002	8
5/16-inch Nut Driver	8720-0003	9
3/8-inch Nut Driver	8720-0005	1
1/2-inch Nut Driver (end covered with heatshrink tubing)	8720-0007	3
9/16-inch Nut Driver (drilled out, end covered with heatshrink tubing)	8720-0008	4
Pozi-driv Screwdriver	8710-0899	0
Long-nose Pliers	8710-0030	1
Wire Cutters	87100012	9
Instrument Grease	6040-0584	7
Tiewraps	1400-0249	0
Small Brush (for Grease Application)	8520-0015	9
Isopropyl Alcohol/Distilled Water Mixture (50%-50%, for use as cleaning solvent)		

REMOVAL OF FRONT SWITCH ASSEMBLY FROM HP 8558B CHASSIS

1. Turn HP 8558B upside down on a flat work surface.

NOTE

Numbers in parentheses match the numerical callouts on Figure 6-3, Front Switch Assembly (exploded view), in Section VI. Unless otherwise indicated, all other illustrations referenced in these procedures follow the last procedural step.

2. Use a 9/16-inch nut driver (drilled out, if necessary, to fit over front panel BNC connectors, and covered with heatshrink tubing or tape to avoid scratching enameled front panel) to remove two dress nuts holding 1 ST LO OUTPUT and CAL OUTPUT connectors to front panel.
3. Use a 5/16-inch open-end wrench to carefully disconnect semi-rigid Cable W14 from RF Input Limiter U1 (cable connects Limiter to Input Attenuator A3).
4. Cut plastic tiewrap holding brown CAL OUTPUT Cable W8 to Front Switch Standoff (69).
5. Disconnect 50-conductor Ribbon Cable A2A1W3 (53) from Motherboard Assembly A16.

6. Turn HP 8558B right-side up, with front panel facing you.
7. Disconnect 14-conductor Ribbon Cable A2AIWI (52) from DPM Driver Assembly A1A2. Fold cable up away from board.
8. Remove the four Screws (19) attaching DPM Driver Assembly A1A2 to DPM Mounting Brackets (20, 21).
9. Disconnect four wires (0, 916, 918, 923) from upper right corner of Front Switch Board Assembly A2A1 (next to FREQUENCY ZERO potentiometer).
10. Remove the four screws attaching Front Switch Diecast (1) to left and right side gussets. Remove Front Switch Assembly A2, with Front Panel and RF Input Attenuator A3, from HP 8558B chassis and set chassis to one side.

DISASSEMBLY OF FRONT SWITCH ASSEMBLY

NOTE

It is not necessary to remove front panel, all connectors, and all knobs to service Front Switch Board Assembly A2A1 (steps 11-24).

11. Remove the following front panel knobs using a no. 4 hex (Allen) wrench: FINE TUNE, COARSE TUNE, RESOLUTION BW, FREQ SPAN/DIV, REF LEVEL FINE, and REFERENCE LEVEL (including Index Disc, Retaining Clip, Nylon Spacer Washer(s), Conical Spring, and Input Attenuator pointer).
12. Remove VIDEO FILTER and BASELINE CLIPPER knobs using a no. 2 spline (Bristol) wrench.
13. Remove dress nut on FREQUENCY CAL pushbutton using a 13/64-inch open-end wrench.
14. Remove front panel hex nut and lockwasher on Coarse Tune Bushing (42) using a 1/2-inch nut driver (covered with heatshrink tubing or tape to avoid scratching enameled front panel).
15. Remove Retaining Clip (25) from RESOLUTION BW Shaft (61).
16. Place Front Switch Assembly on flat working surface with remaining knobs face-down and lock mechanism facing you. Prop sides of switch assembly to allow knobs and shafts to clear working surface (be careful not to scratch front panel enamel).
17. Loosen hex nut attaching RF Input Cable Assembly W1 to Front Switch Assembly using a 5/8-inch open-end wrench (*Options 001 and 002: Loosen front panel dress nut with special 9/16-inch nut driver*). Carefully disconnect input cable assembly from RF Input Attenuator A3 using a 5/16-inch open-end wrench. Remove input cable assembly from Front Switch Assembly.
18. Remove Screw (19) and Washer (56) attaching Attenuator Bracket (55) to Front Switch Diecast (1). Remove RF Input Attenuator A3 from Front Switch Assembly.
19. Disassembly of REFERENCE LEVEL Switch:
 - a. Cut tiwrap holding REF LEVEL FINE wires to Standoff (69).
 - b. Remove the three Screws (54) attaching Ref Level Fine Pot Plate (75) to Standoffs (69).
 - c. Remove Index Disc Locator and Ref Level Fine Assembly (35, 36, and 71 through 76) from Front Switch Assembly (set to one side, without detaching wires).

- d. Remove three Standoffs (69) used to support Ref Level Fine Pot Plate (75). Use a no. 6 hex wrench to loosen the two set screws on Miter Gear (57) attached to Attenuator Shaft Assembly (17); then remove Miter Gear from shaft.
- e. Use a no. 4 hex wrench to loosen Rotating Lockout (70) attached to Ref Level Shaft (6), and remove lockout from shaft. Remove Ref Level Detent (68) from Front Switch Assembly. Be careful to keep Ball Bearing (10) and Spring (11) with Ref Level Rotor (67).
- f. Remove the three Studs (59) used to support Ref Level Detent (68).
- g. Use a no. 4 hex wrench to loosen the two set screws on front Anticrush Drive Hub Assembly (7) (between Front Switch Board A2A1 and Front Switch Diecast (1) on Ref Level Shaft (6); accessible from side of Front Switch Assembly). Remove Ref Level Rotor (67) and Ref Level Shaft (6) with rear Anticrush Drive Hub Assembly (7) still attached.

NOTE

Rear Anticrush Drive Hub Assembly (7) on Ref Level Shaft (6) is preset at 9.525 mm (03 in.) from end of shaft (see Figure 848A). Do not remove drive hub unless necessary for repair.

20. Disassembly of RESOLUTION BW Switch.
 - a. Use a 1/4-inch Nut Driver to remove two Hex Nuts (22) attaching Bandwidth Switch Board (66) to Front Switch Assembly, and set board to one side (without detaching wires).
 - b. Remove Rotor Spacer (64) and Bandwidth Rotor (63). Be careful to keep Ball Bearings (10) and Springs (62) with rotor.
 - c. Remove Bandwidth Shaft (61), with rear Drive Hub (14) still attached, from Front Switch Assembly.

NOTE

Rear Drive Hub (14) on Bandwidth Shaft (61) is preset flush with collar on shaft (see Figure 848B). Do not remove drive hub unless necessary for repair.

- d. Use a no. 4 hex wrench to loosen the two screws on Coupling Hub (60) attached to Frequency Span Shaft (9), and remove hub from shaft.
 - e. Remove the two Studs (59) used to support Bandwidth Switch Board (66). Remove Bandwidth Detent (58) from Front Switch Assembly.
21. Disconnect Probe Power wires (0, 92, 97) from Front Switch Board Assembly A2A1.
 22. Remove Screw (23) and Spacer (24) attaching Front Switch Board Assembly A2A1 to Front Switch Diecast (1) above DPM Display.
 23. Remove the three remaining Screws (54, not shown in Figure 6-3) attaching Front Switch Board Assembly A2A1 to Front Switch Diecast (1).
 24. Twist the left side of Front Switch Board Assembly A2A1 down approximately 1/8-inch to provide clearance from Front Switch Diecast support arm (upper left corner). Lift Front Switch Board Assembly A2A1 from Front Switch Diecast (1) and set aside.

25. Removal of Rotor Assemblies:
 - a. Remove Attenuator Drive Rotor (8), front Anticrush Drive Hub Assembly (7), and Attenuator Shaft Assembly (17) from Front Switch Diecast (1), and set these parts aside.
 - b. Remove Frequency Span Rotor (13) with associated parts (9-12, 14-16) from Front Switch Diecast (1), and set aside. Be careful to keep Ball Bearings (10) and Springs (11) with Frequency Span Rotor (13).

NOTE

Drive Hub (14) on Frequency Span Shaft (9) is preset at 12.954 mm (0.510 in.) from end of shaft (see Figure 848C). Do not remove drive hub from shaft unless necessary for repair.

- c. Remove SWEEP TRIGGER, MANUAL SWEEP, and SWEEP TIME/DIV knobs using a no. 4 hex wrench.
 - d. Remove both remaining rotor assemblies from Front Switch Diecast (1), and set aside. Be careful to keep Ball Bearings (10) and Springs (27) with their respective rotors.
26. Use a no. 4 hex wrench to loosen the two set screws in Lock Knob. Remove Lock Knob.
27. Use a 5/16-inch nut driver to remove the two nuts attaching front panel to Front Switch Diecast (1). Remove front panel from Front Switch Diecast.
28. Disassembly of Lock:
 - a. Press Locking Link (5) into Front Switch Diecast (1) to release pressure on Dowel Pin (4). Remove Dowel Pin through cutout in Front Switch Diecast. (Individual parts are identified in Figure 8-50.)
 - b. Remove Locking Link (5), Locking Shaft (3), and Lock Spring (2) from Front Switch Diecast.

CLEANING AND INSPECTION OF FRONT SWITCH ASSEMBLY

1. All switch contacts must be totally clean and grease-free for proper operation. Use a 50-50 mixture of isopropyl alcohol and distilled water to thoroughly clean switch rotor contacts and Front Switch Board Assembly A2A1. Avoid touching contacts with fingers.
2. Inspect for bent or damaged shafts, worn or broken contacts, weak or broken springs, rough feeling potentiometers, cracked castings, and damaged PC boards. Check for signs of corrosion or rust. Replace any suspect parts.
3. A special Instrument Grease, (see list of Tools and Materials at beginning of these procedures) is recommended exclusively for use during switch reassembly. Lubrication is essential for proper operation of switches and lock. A small brush is recommended for applying the Instrument Grease.

CAUTION

Misapplied grease might cause intermittent switch connections. Utmost care must be taken during reassembly to avoid excessive application of grease and contamination of switch contacts. Avoid getting grease on fingers.

ASSEMBLY OF FRONT SWITCH ASSEMBLY

1. Assembly of Lock:
 - a. Lightly grease Locking Shaft (3) and insert into Front Switch Diecast (1). Lightly grease bearing surfaces of Locking Link (5).
 - b. Insert Lock Spring (2) into Front Switch Diecast (1). Press Locking Link (5) fully into Front Switch Diecast and insert Dowel Pin (4) through access cutout (left side of lock boss) to hold lock mechanism in place. Check for correct lock operation.

CAUTION

Pressed-in mounting studs on front panel will break if overtightened.

2. Use a 5/16-inch nut driver and two hex nuts to carefully install front panel (with pushbutton bezels and DPM window installed) on Front Switch Diecast (1).
3. Use a no. 4 hex (Allen) wrench to install lock knob on Locking Shaft (3). Base of Lock Knob should clear front panel when Locking Shaft is pushed in.
4. Installation of Rotor Assemblies:
 - a. Lightly grease all switch rotor detent holes on back of Front Switch Diecast (1).
 - b. Place Front Switch Assembly on flat working surface with front panel face-down and lock mechanism facing you. Prop sides of switch assembly to provide clearance for knobs and shafts during assembly (be careful not to scratch front panel enamel).
 - c. Inspect SWEEP TRIGGER rotor assembly (10, 12, 27-31). Stop Arm (30) and Horseshoe Spring (31) are held in position by Push-on Retainer (29) and should move smoothly without binding (see Figure 849A). Roll Pins (12) should be positioned in hole 7 and hole 18 on SWEEP TRIGGER Rotor (28). Check that Spring (27) and Ball Bearing (10) are in position.
 - d. Lightly grease long side of SWEEP TRIGGER Shaft (28) and insert SWEEP TRIGGER rotor assembly into left-most bushing in Front Switch Diecast (1). Position rotor so that Ball Bearing (10) aligns with stop boss on left side of Front Switch Diecast (see Figure 8-51).
 - e. Inspect SWEEP TIME/DIV rotor assembly (10, 25-28), Figure 8-49B. MANUAL SWEEP Shaft (26) should be lightly greased and should turn freely inside SWEEP TIME/DIV Shaft (28). Check that Spring (27) and Ball Bearing (10) are in position. Note that there are no roll pins inserted in the SWEEP TIME/DIV Rotor (28).
 - f. Lightly grease long side of SWEEP TIME/DIV Shaft (28) and insert SWEEP TIME/DIV rotor assembly into next bushing in Front Switch Diecast (1) (see Figure 8-51).
 - g. Inspect FREQ SPAN/DIV rotor assembly (9-16). If Drive Hub (14) has been loosened or removed from Frequency Span Shaft (9), refer to Figure 8-49C for correct dimensions for adjustment. Roll Pins (12) should be positioned in hole 1 and hole 16 on Frequency Span Rotor (13), as shown in Figure 849C. Slotted Bushing (15), Hairpin Spring (16), and Frequency Span Shaft must be lightly greased where they contact each other for proper operation of push-pull mechanism. Check that Springs (11), Ball Bearings (10), Slotted Bushing, and Hairpin Spring are in correct position.

- h. Lightly grease long side of Frequency Span Shaft (9) and insert FREQ SPAN/DIV rotor assembly (9-16) into next bushing in Front Switch Diecast (1). Position FREQ SPAN/DIV rotor assembly so that stop boss on Front Switch Diecast does not fall within small span between Roll Pins (12), as shown in Figure 8-51.
- i. Inspect Attenuator Drive Rotor (8). Roll Pins (12) should be positioned in hole 1 and hole 9, as shown in Figure 8-49D.
- j. Inspect front Anticrush Drive Hub Assembly (7). Note that pin is offset to one side of drive hub; place drive hub over right-most bushing in Front Switch Diecast (1) with this side down (i.e., pin as close as possible to Front Switch Diecast) for proper switch operation.

NOTE

Correct side of front Anticrush Drive Hub (7) must be oriented towards Front Switch Diecast (1) for proper operation of Front Switch Assembly.

- k. Set Attenuator Drive Rotor (8) over Anticrush Drive Hub (7) with Attenuator Drive Rotor gear facing up. Long pin on Attenuator Drive Rotor should protrude through curved slot in diecast.
 - l. Lightly grease gear end of Attenuator Shaft Assembly (17) and insert into Front Switch Diecast (1) as shown in Figure 8-51. Place metal Washer (18) on shaft.
 - m. Clean contact fingers on all rotors using lint-free cloth and isopropyl alcohol/distilled water mixture. All rotors should be in proper position as shown in Figure 8-51.
5. Installation of Front Switch Board Assembly A2A1:
- a. Inspect Front Switch Board Assembly. Check switch traces for dirt, grease, or wear. Check interconnect wires, solder joints, pushbutton switches, and ribbon cables (52, 53).
 - b. Clean switch traces using lint-free cloth and isopropyl alcohol/distilled water mixture. No residue should be visible on traces.
 - c. Use a 1/4-inch nut driver to tighten Hex Nuts (22) and Screws (19) fastening DPM Mounting Brackets (20, 21) to Front Switch Board Assembly.
 - d. Use a 3/8-inch open-end wrench to tighten Hex Nut (36) and Lockwasher (35) attaching FREQUENCY ZERO Potentiometer (37) to Front Switch Board Assembly. Use a no. 2 spline (Bristol) wrench to install FREQUENCY ZERO Knob (34).
 - e. Use a 3/8-inch open-end wrench to tighten Hex Nut (36) and Lockwasher (35) attaching VIDEO FILTER Potentiometer (39) and metal Washer (38) to Front Switch Board Assembly.
 - f. Use a 1/2-inch open-end wrench to tighten inner Hex Nut (32) and Washer (33) attaching Dual Tune Pot assembly (25, 32, 33, 40-51, 77) to Front Switch Board Assembly. Note that Roll Pin (12) aligns with hole in switch board to locate Dual Pot Bracket (45); Washer (33) between bracket and switch board is critical to proper switch operation. See Figure 8-52 for front view of assembled switch board.
 - g. Check Dual Tune Pot assembly for smooth operation and proper gear meshing; disassemble and lightly grease shafts if necessary. Install second Hex Nut (32) mid-way onto Coarse Tune Shaft Bushing (42).
 - h. Set Front Switch Board Assembly into place on partially-assembled Front Switch Assembly and use a Stud (59) on right-most side of switch assembly to loosely fasten switch board to Front Switch Diecast (1).

- i. With one Stud (59) in place but not tight, twist left side of Front Switch Board Assembly up approximately 1/8-inch to fasten switch board under Front Switch Diecast support arm (upper left corner) and align switch shafts.
- j. Loosely install the three remaining Screws (54, not shown in Figure 6-3) used to fasten Front Switch Board Assembly to Front Switch Diecast (1).
- k. Use a no. 4 hex wrench to temporarily install SWEEP TRIGGER, SWEEP TIME/DIV, MANUAL SWEEP, and FREQ SPAN/DIV knobs. Insert FREQUENCY CAL pushbutton through front panel and fasten with dress nut. Use a 13/64-inch open-end wrench to tighten nut to front panel.

CAUTION

Do not overtighten screws and studs into Front Switch Diecast (1).

- l. Tighten Stud (59) and left-most Screw (54) attaching Front Switch Board Assembly to Front Switch Diecast (1). Check all switch rotors for smooth, free switch action. Readjust position of Front Switch Board Assembly as necessary for proper switch action.
 - m. Install Screw (23) and Spacer (24) used to attach Front Switch Board Assembly to Front Switch Diecast (1) above DPM Display.
 - n. Tighten the two remaining Screws (54) attaching Front Switch Board Assembly to Front Switch Diecast (1).
 - o. Recheck all switch rotors for smooth, free switch action and readjust Front Switch Assembly as necessary.
 - p. Connect PROBE POWER wires (0, 92, 97) to respective pins on Front Switch Board Assembly.
6. Assembly of RESOLUTION BW Switch:
- a. Place Coupler Hub (60) on Frequency Span Shaft (9) with pin facing up (away from Front Switch Assembly). Do not tighten Coupler Hub at this time.
 - b. Center Bandwidth Detent (58) over Coupler Hub (60) with stop tab towards top of Front Switch Assembly, and fasten to Front Switch Assembly using two Studs (59).
 - c. If Drive Hub (14) has been removed or loosened from Bandwidth Shaft (61), refer to Figure 8-48B for proper adjustment. Lightly grease narrow end of Bandwidth Shaft (61) and detent holes on Bandwidth Detent (58). Insert Bandwidth Shaft (61) through Frequency Span Shaft (9).
 - d. Inspect RESOLUTION BW Rotor (63). Roll Pins (12) should be positioned in hole 1 and hole 18 as shown in Figure 8-49E. Check that Springs (62) and Ball Bearings (10) are in position.
 - e. Place RESOLUTION BW Rotor (63) onto Bandwidth Shaft (61). Position RESOLUTION BW Rotor assembly so that stop tab does not fall within small span between Roll Pins (12).
 - f. Place Rotor Spacer (64) onto RESOLUTION BW Rotor (63).
 - g. Clean contact fingers on RESOLUTION BW Rotor and switch traces on Bandwidth Switch Board (66) using lint-free cloth and isopropyl alcohol/distilled water mixture.
 - h. Use a 1/4-inch nut driver to fasten Bandwidth Switch Board (66) to Front Switch Assembly with two Hex Nuts (22). End of Bandwidth Shaft (61) must not bind against hole in board. Align MANUAL SWEEP Shaft (26) with MANUAL SWEEP Potentiometer (65) by turning MANUAL SWEEP knob clockwise until shaft engages with MANUAL SWEEP Potentiometer.

NOTE

Depth of MANUAL SWEEP Shaft (26) can be adjusted if necessary by carefully tapping SWEPTIME/DIV Shaft (28) farther into the white plastic rotor.

- i. Turn Front Switch Assembly over and remove FREQ SPAN/DIV knob using a no. 4 hex wrench.
 - j. Install Retainer Clip (25) on Bandwidth Shaft (61).
 - k. Use a no. 4 hex wrench to temporarily install FREQ SPAN/DIV and RESOLUTION BW knobs.
 - l. Pull and turn FREQ SPAN/DIV Knob until a set screw is visible on Coupling Hub (60). Push FREQ SPAN/DIV knob in and out to align pin on Coupling Hub with slots in Bandwidth Rotor (63). With FREQ SPAN/DIV knob pushed in and Coupling Hub flush against Bandwidth Rotor (pin aligned), tighten set screw using a no. 4 hex wrench. Turn FREQ SPAN/DIV knob until second set screw is visible, and tighten second set screw.
 - m. Push FREQ SPAN/DIV knob in and out while observing Bandwidth Rotor (63). Bandwidth Rotor will not move if Coupling Hub (60) is properly aligned. Readjust Coupling Hub as necessary for proper operation.
7. Assembly of REFERENCE LEVEL Switch:
- a. Install remaining two Studs (59) on Front Switch Assembly. Check that all screws and studs have been tightened.
 - b. If rear Anticrush Drive Hub Assembly (7) has been loosened or removed from Ref Level Shaft (6), refer to Figure 8-48A for correct dimensions for adjustment.
 - c. Inspect Ref Level Rotor (67). Roll Pins (12) should be positioned in hole 1 and hole 9, as shown in Figure 849F. Check that Spring (11) and Ball Bearing (10) are in position. Insert Ref Level Shaft (6) through Ref Level Rotor so that rear Anticrush Drive Hub (7) seats properly into rotor.
 - d. Lightly grease long end of Ref Level Shaft (6) and insert through Front Switch Board Assembly A2A1, Attenuator Drive Rotor (8), front Anticrush Drive Hub (7), and bushing in Front Switch Diecast (1).
 - e. Lightly grease detent holes on flat side of Ref Level Detent (68). Mount detent on three Studs (59) and fasten tightly with three Standoffs (69).

CAUTION

Hollow Ref Level Shaft (6) might be damaged if set screws in Rotating Lockout (70) are tightened excessively.

- f. Place Rotating Lockout (70) on Ref Level Shaft (6) with teeth flat against Ref Level Detent (68). Lockout teeth should be aligned to miss pin on Ref Level Detent when Ref Level Shaft is pushed in (switch in any detent position). With Ref Level Shaft fully extended from front panel, use a no. 4 hex wrench to tighten Rotating Lockout.
- g. Push Ref Level Shaft (6) in and out and check for smooth mechanical feel and proper Rotating Lockout (70) alignment. Rotating Lockout should not bind against Ref Level Detent (68) and should allow Ref Level Shaft to turn smoothly between detent positions. Adjust Rotating Lockout as necessary for proper operation.

- h. Use a no. 4 hex wrench to lightly tighten one set screw in front Anticrush Drive Hub (7) visible between Attenuator Drive Rotor (8) and Front Switch Diecast (1).
 - i. Turn Attenuator Drive Rotor (8) so that long pin (for Input Attenuator pointer) is at bottom of Front Switch Diecast (1). Hold Attenuator Drive Rotor in position and push in on Ref Level Shaft (6) to align front Anticrush Drive Hub (7).
 - j. Push Ref Level Shaft (6) in and out while observing Ref Level Rotor (67) and Attenuator Drive Rotor (8). Rotors will not move when front Anticrush Drive Hub (7) is properly adjusted.
 - k. Use a no. 4 hex wrench to firmly tighten both set screws in front Anticrush Drive Hub (7). Recheck Ref Level Shaft (6) as in step j, and readjust front Anticrush Drive Hub as necessary.
 - l. Slip Miter Gear (57) over Attenuator Shaft Assembly (17). Do not tighten at this time.
 - m. Inspect Ref Level Fine Assembly (35, 36, 72-76). Ref Level Fine Shaft (72) should turn smoothly. Check Ref Level Fine Potentiometer (76) and connecting wires for good electrical connections. Lightly grease Ref Level Fine Shaft and hollow Index Disc Locator (71) shaft.
 - n. Install Index Disc Locator (71) on Front Switch Assembly. Hole in locator bar rides over left-most Standoff (69) used to support Ref Level Fine Pot Plate (75). Install Ref Level Fine Assembly (35, 36, 72-76) on Front Switch Assembly with three Screws (54). Connecting wires should be routed as shown in Figure 8-53. Ref Level Fine Shaft (72) should turn smoothly without binding over its full rotation. Adjust position of Ref Level Fine Pot Plate as necessary.
 - o. Use a new tiewrap to attach Ref Level Fine connecting wires to Standoff (69) as shown in Figure 8-53.
8. Installation of RF Input Attenuator A3:
- a. Mount RF Input Attenuator to Attenuator Bracket (55) using two Screws (53). Check all eight attenuator positions by hand for proper detent action and smooth operation. Leave attenuator in full counter-clockwise position.
 - b. Slide Miter Gear (57) to end of Attenuator Shaft Assembly (17) against Ref Level Fine Pot Plate (75). Set Attenuator Assembly in place on Front Switch Assembly, with notch in Attenuator Bracket (55) lightly greased and aligned with Attenuator Shaft Assembly. Use Washer (56) and Screw (19) to fasten Attenuator Bracket to lower left corner of Front Switch Diecast (1). (Do not tighten Miter Gear at this time.)
 - c. Insert RF Input Cable Assembly W1 through front panel and loosely attach with hex nut. Carefully connect cable assembly to RF Input Attenuator using a 5/16-inch open-end wrench. Tighten cable assembly to front panel using a 5/8-inch open-end wrench (*Options 001 and 002: use special 9/16-inch nut driver to tighten front panel dress nut*).

NOTE

Front-panel control knobs and their attaching parts are identified in Figure 6-2. Numbers in parentheses match numerical callouts on Figure 6-3.

9. Installation of Knobs:
- a. Turn SWEEP TRIGGER Shaft (28) fully clockwise (as seen from front of Front Switch Assembly) to spring-loaded SINGLE position and release. Use a no. 4 hex wrench to install SWEEP TRIGGER knob with SINGLE line aligned with painted arrow on front panel. Check for proper switch operation and alignment.

- b. Turn SWEEP TIME/DIV Shaft (28) to align Ball Bearing (10) on SWEEP TIME/DIV Rotor with left-most edge of stop boss on Front Switch Diecast (1). This positions SWEEP TIME/DIV Rotor with Ball Bearing slightly right of 12 o'clock position (as seen from front of Front Panel Assembly). Use a no. 4 hex wrench to lightly tighten SWEEP TIME/DIV knob onto SWEEP TIME/DIV Shaft with approximate center of green AUTO position aligned with painted arrow on front panel. Turn SWEEP TIME/DIV knob to any calibrated sweep time position and align knob markings exactly with painted arrow on front panel. Tighten SWEEP TIME/DIV knob and check for proper switch operation and alignment.
- c. Uncouple RESOLUTION BW Shaft (61) from FREQ SPAN/DIV Shaft (9) by pulling both shafts out. Turn each shaft fully clockwise. Use a no. 4 hex wrench to install FREQ SPAN/DIV knob with 100 MHz indicated, checking that the plastic indicator guide on back of knob does not completely bottom into hole in Front Switch Diecast (1). Install RESOLUTION BW Knob with 3 MHz indicated. Check for proper operation and alignment of both switches. Push-pull action should be smooth and positive.
- d. Set nylon shim washer(s) and Index Disc (see Figure 6-2) in place on REFERENCE LEVEL knob to check for proper shim width. Nylon washers should shim Index Disc slightly away from labelled ring on REFERENCE LEVEL knob to prevent rubbing against painted numbers. Add or remove shim washers as necessary to provide slight clearance.
- e. Turn Attenuator Drive Rotor (8) fully counter-clockwise so that Input Attenuator Pointer guide pin (P/O 8) is at bottom of front panel. Turn Ref Level Shaft (6) fully clockwise. Place plastic Input Attenuator Pointer over guide pin (pointer should indicate 70 dB). Place large end of conical spring against Input Attenuator Pointer and slide REFERENCE LEVEL knob, nylon washer(s), and Index Disc (from step d) onto Ref Level Shaft, securing with retainer clip.
- f. Use a no. 6 hex wrench to adjust Miter Gears (57) for alignment of Input Attenuator Pointer with 70 dB front panel label and proper gear mesh (Input Attenuator A3 still in full counter-clockwise position).
- g. Turn REFERENCE LEVEL knob to indicate level of CAL OUTPUT signal (i.e., -30 dB; Option 002: +20 dBm V) and tighten knob securely with a no. 4 hex wrench. Check for proper operation and alignment of REFERENCE LEVEL and INPUT ATTEN controls, and readjust knob, gears, and Rotating Lockout (70) as necessary. Reference Level should range from -10 dBm to -100 dBm with 0 dB INPUT ATTEN selected (*Option 002: +40 dBm V to -50 dBm*).
- h. Turn REF LEVEL FINE Shaft (72) fully counter-clockwise and use a no. 4 hex wrench to install REF LEVEL FINE knob with 0 dB indicated. Check for proper operation and alignment and readjust knob as necessary.
- i. Turn BASELINE CLIPPER Shaft and VIDEO FILTER Shaft (39) fully counter-clockwise and use a no. 2 spline wrench to install BASELINE CLIPPER and VIDEO FILTER knobs in OFF position. Check for proper operation and alignment and readjust as necessary.
- j. Loosely tighten second Hex Nut (32) on Coarse Tune Bushing (42) against Front Switch Diecast (1). Install front panel nut and washer on Coarse Tune Bushing and tighten with special 1/2-inch nut driver.
- k. Use a no. 4 hex wrench to install COARSE TUNE and FINE TUNE knobs. Base of COARSE TUNE knob should clear front panel. Check for proper operation of TUNING control.

INSTALLATION OF FRONT SWITCH ASSEMBLY INTO HP 8558B CHASSIS

10. Set Front Switch Assembly into place in chassis, being careful not to bend semi-rigid cables or pinch wires or ribbon cables. Attach Front Switch Diecast (1) to left and right side gussets with four screws.
11. Connect four wires (0, 916, 918, 923) to correspondingly 4 labelled pins in upper right corner of Front Switch Board A2A1.
12. Attach DPM Driver Assembly A1A2 to DPM Mounting Brackets (20, 21) with four Screws (19).
13. Connect 14-conductor Ribbon Cable A2A1W1 (52) to DPM Driver Assembly A1A2.
14. Connect 50-conductor Ribbon Cable A2A1 W2 (53) to Motherboard Assembly A16.
15. Use a 5/16-inch open-end wrench to carefully connect Semi-rigid Cable W14 to RF Input Limiter U1.
16. Use special 9/16-inch nut driver to install CAL OUTPUT and 1ST LO OUTPUT connectors to front panel with two dress nuts.
17. Attach brown CAL OUTPUT Cable W8 to Front Switch Standoff (69) with tiwrap.
18. Slide HP 8558B into display mainframe, turn instrument ON, and verify proper operation of all controls.

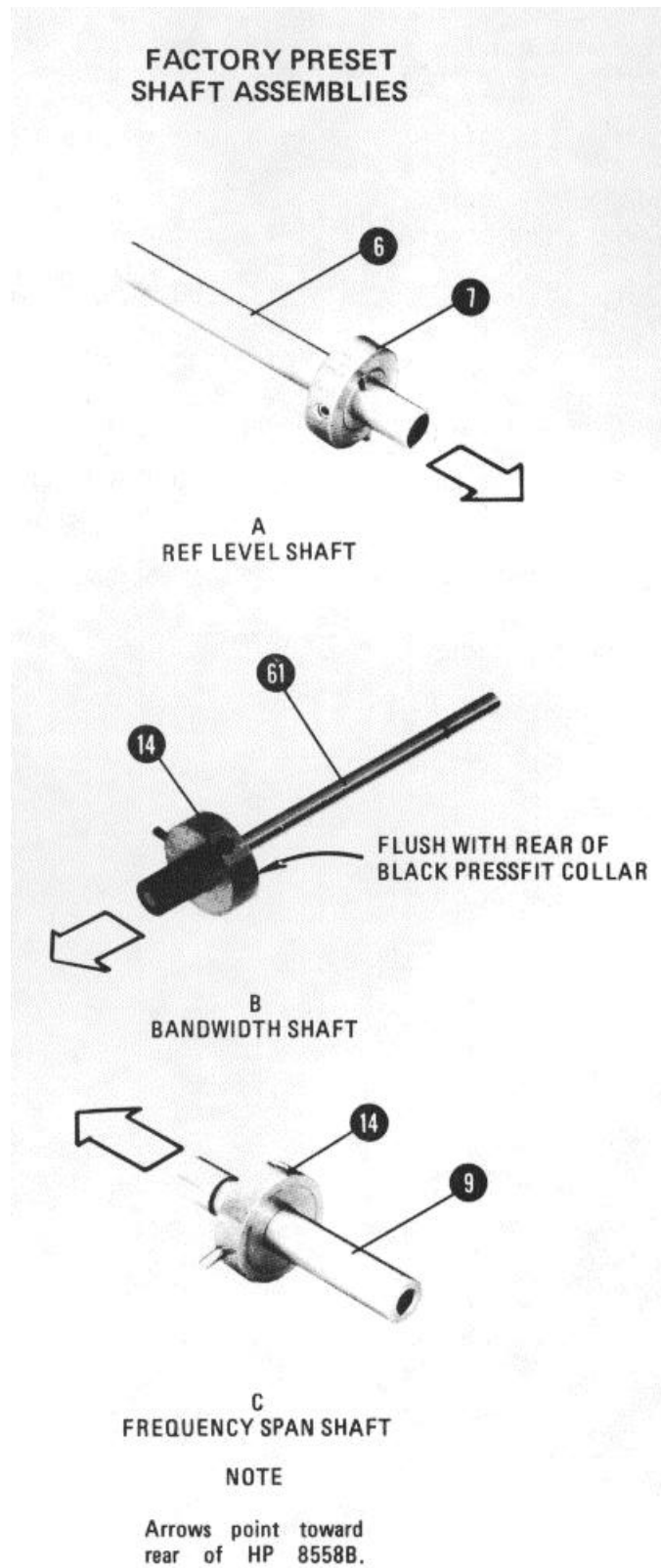

Figure 8-48. Shaft Assemblies

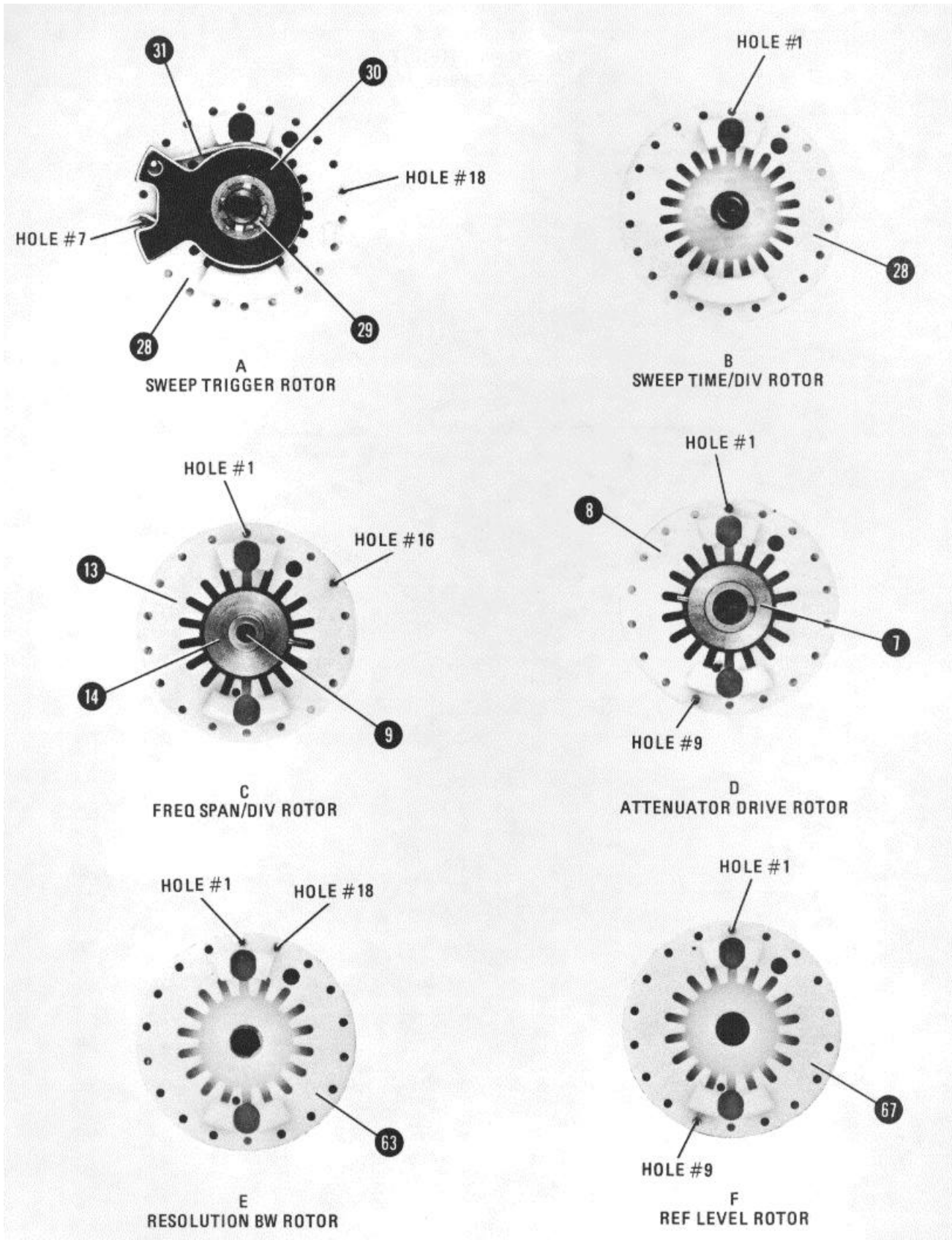

Figure 8-49. Rotor Assemblies

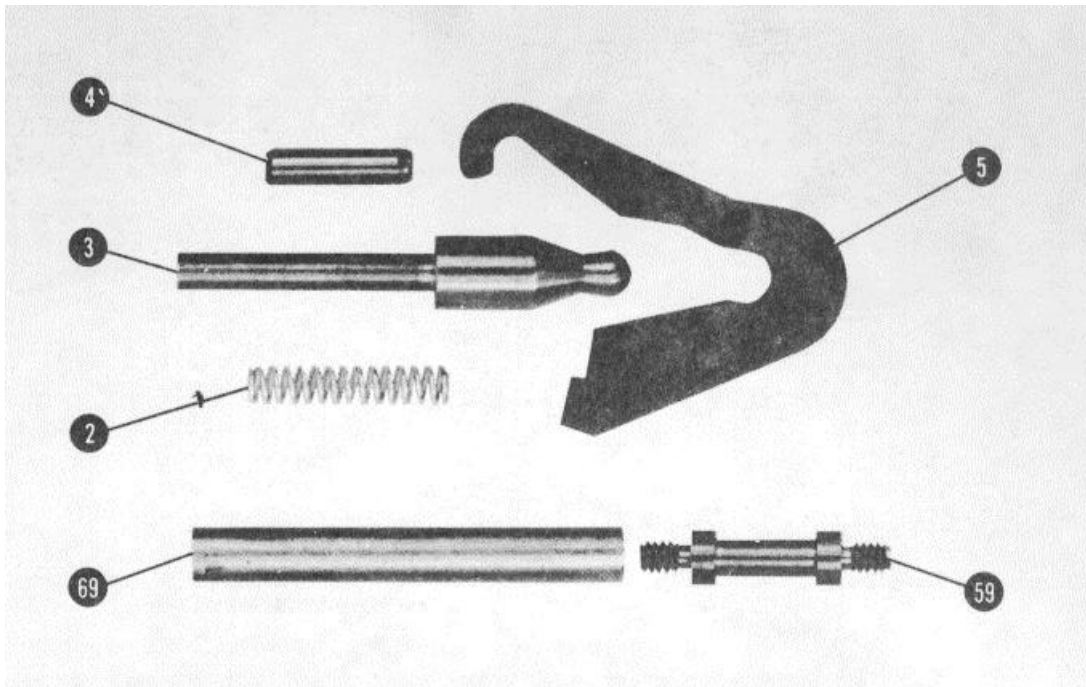

Figure 8-50. Machined Parts

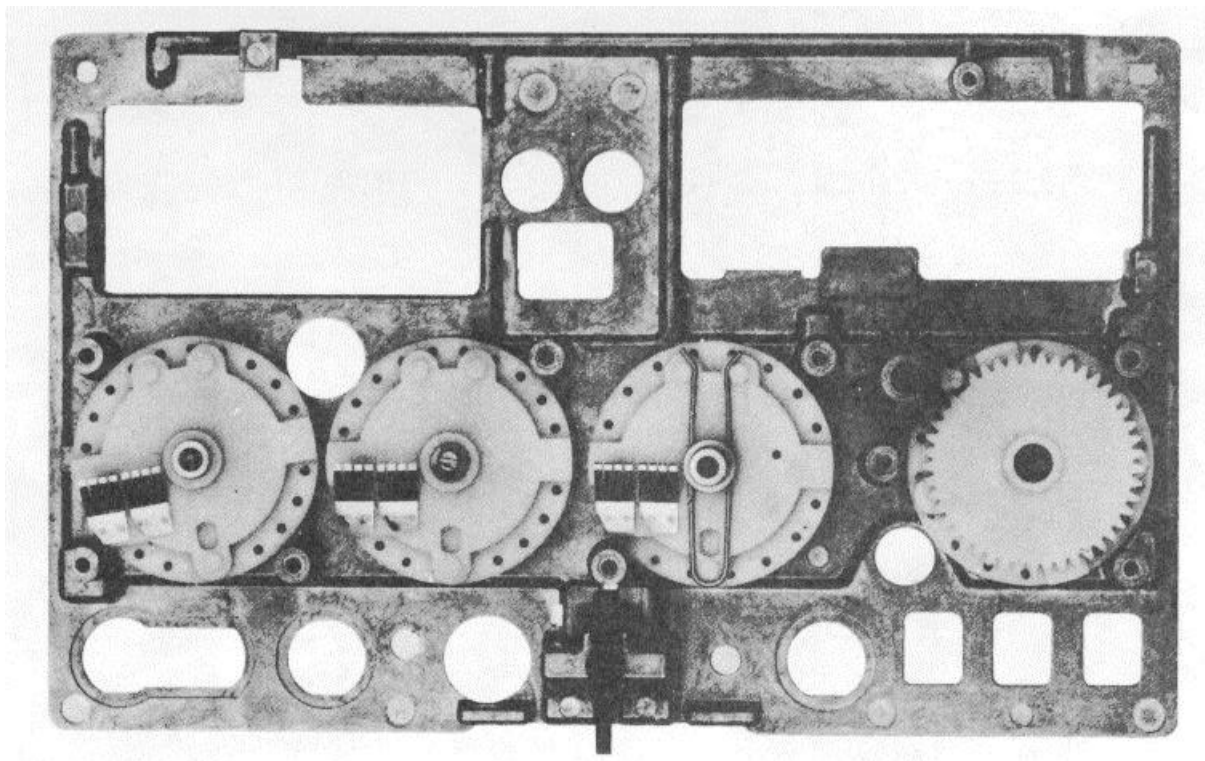

Figure 8-51. Proper Positioning of Rotors on Front Switch Diecast

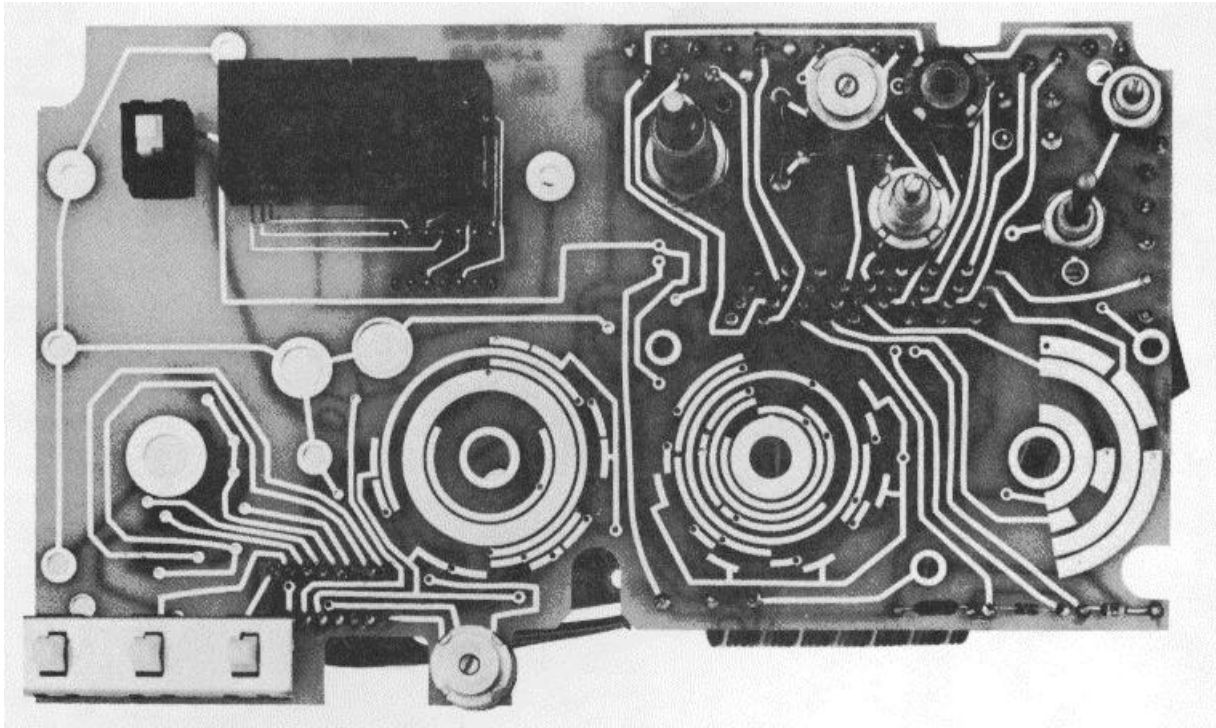

Figure 8-52. Front View of Switchboard Assembly A2A1

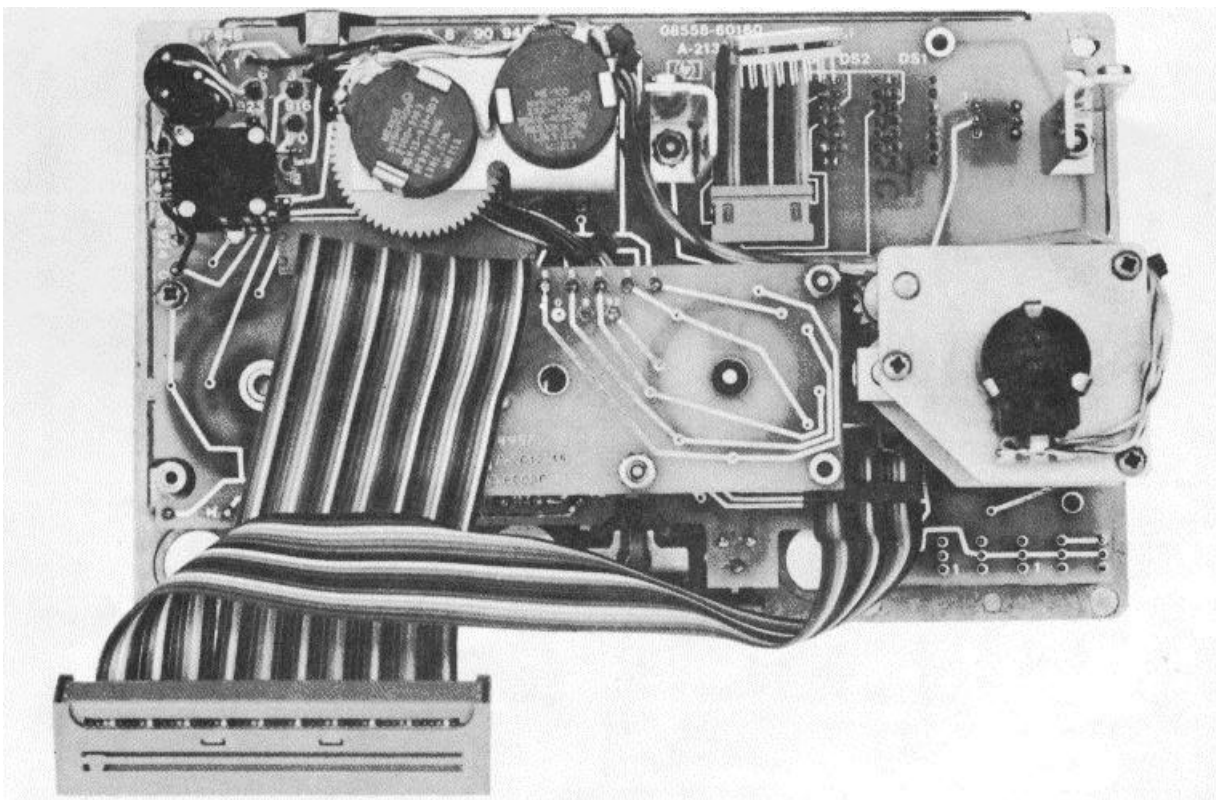

Figure 8-53. Rear View of Front Switch Assembly A2

APPENDIX A

REFERENCES

- | | |
|---------------------|--|
| DA Pam 310-1 | Consolidated Index of Army Publications and Blank Forms. |
| DA Pam 738-750 | The Army Maintenance Management System (TAMMS). |
| TM 750-244-2 | Procedures for Destruction of Electronics Materiel to Prevent Enemy Use (Electronics Command). |
| TM 11-6625-3061-24P | Organizational, Direct Support, and General Support Maintenance, Repair Parts and Special Tools List, and Maintenance Allocation Chart for Spectrum Analyzer Hewlett-Packard Model 8558B |

A-1/(A-2 blank)

APPENDIX B**COMPONENTS OF END ITEM LIST****Section I. INTRODUCTION****B-1. Scope**

The appendix lists integral components of and basic issue items for Spectrum Analyzer, HP Model 8558B to help you inventory items required for safe and efficient operation.

B-2. General

This Components of End Item List is divided into the following sections:

a. Section II. Integral Components of the End Item. These items, when assembled, comprise the Spectrum Analyzer, HP Model 8558B and must accompany it whenever it is transferred or turned in. The illustrations referenced will help you in identify these items.

b. Section III. Basic Issue Items. Not applicable.

B-3. Explanation of Columns

a. Illustration. This column is divided as follows:

- (1) Figure number. Indicates the figure number of the illustration on which item is shown.
- (2) Item number. The number used to identify item called out in the illustration.

b. National Stock Number. Indicates the National Stock Number assigned to the item and which will be used for requisitioning.

c. Description. Indicated the Federal item name and, if required, a minimum description to identify the item. The part number indicated the primary number used by the manufacturer, which controls the design and characteristics of the item by means of its engineering drawings, specifications, standards, and inspection requirements to identify an item or range of items. Following the part number, the Federal Supply Code for Manufacturers (FSCM) is shown in parentheses.

d. Location. The physical location of each item listed is given in the column. The lists are designed to inventory all items in one

area of the major item before moving in to an adjacent area.

e. Usable on Code. Not applicable.

f. Quantity Required (Qty Reqd). This column lists the quantity of each item required for a complete major item.

g. Quantity. This column is left blank for use during the inventory. Under the Rcvd column, list the quantity you actually receive on your major item. The Date columns are for your use when you inventory the major item.

Section II. INTEGRAL COMPONENTS OF END ITEM

(1) ILLUSTRATION (A) FIG. NO.		(B) ITEM NO.	(2) NATIONAL STOCK NUMBER	(3) DESCRIPTION PART NUMBER CAGE		(4) LOCATION	(5) USUABLE ON CODE	(6) QTY REQD	(7) QUANTITY RCVD DATE	
				SPECTRUM ANALYZER, HP MODEL 8558B	28480					

APPENDIX D

MAINTENANCE ALLOCATION

Section I. INTRODUCTION

D-1. General

This appendix provides a summary of the maintenance operations for Spectrum Analyzer, HP Model 8558B. It authorizes categories of maintenance for specific maintenance function on repairable items and components and the tools and equipment required to perform each function. This appendix may be used as an aid in planning maintenance operations.

D-2. Maintenance Function

Maintenance functions will be limited to and defined as follows:

a. Inspect. To determine the serviceability of an item by comparing its physical, mechanical, and/or electrical characteristics with established standards through examination.

b. Test. To verify serviceability and to detect incipient failure by measuring the mechanical or electrical characteristics of an item and comparing those characteristics with prescribed standards.

c. Service. Operations required periodically to keep an item in proper operating condition; ie., to clean (decontaminate), to preserve, to drain, to paint, or to replenish fuel, lubricants, hydraulic fluids, or compressed air supplies.

d. Adjust. To maintain, within prescribed limits, by bringing into proper or exact position, or setting the operating characteristics to specified parameters.

e. Align. To adjust specified variable elements of an item to bring about optimum or desired performance.

f. Calibrate. To determine and cause corrections to be made or to be adjusted in instruments or test measuring and diagnostics equip-

ments use in precision measurement. Consists of comparison of two instruments, one in which is a certified standard of known accuracy of the instrument being compared.

g. Install. The act of emplacing, seating, or fixing into position an item, part, module (component or assembly) in a manner to allow the proper functioning of the equipment or system.

h. Replace. The act of substituting a serviceable like type part, subassembly, or module (component or assembly) for an unserviceable counterpart.

i. Repair. The application of maintenance services (inspect, test, service, adjust, align, calibrate, replace) or other maintenance actions (welding, grinding, riveting, straightening, facing, remachining, or resurfacing) to restore serviceability to an item by correcting specific damage, fault, malfunction, or failure in a part, subassembly, module (component or assembly), end item, or system. This function does not include the trial and error replacement of running spare type items such as fuses, lamps, or electron tubes.

j. Overhaul. That maintenance effort (service/action) necessary to restore an item to a completely serviceable/operational condition as prescribed by maintenance standards (.i.e., DMWR) in appropriate technical publications. Overhaul is normally the highest degree of maintenance performed by the Army. Overhaul does not normally return an item to like new condition.

k. Rebuild. Consists of those services/actions necessary for the restoration of unserviceable equipment to a like new condition in accordance with original manufacturing standards. Rebuild is the highest degree of materiel maintenance applied to Army equipment. The rebuild operation includes the act of returning to zero those age measurements (hours, miles, etc.) considered in classifying Army equipments/components.

D-3. Column Entries

a. Column 1, Group Number. Column 1 lists group numbers, the purpose of which is to identify components, assemblies, subassemblies,

and modules with the next higher assembly.

b. Column 2, Component/Assembly. Column 2 contains the noun names of components, assemblies, subassemblies, and modules for which maintenance is authorized,

c. Column 3, Maintenance Functions. Column 3 lists the functions to be performed on the item listed column 2. When items are listed without maintenance functions, it is solely for purpose of having the group numbers in the MAC and RPSTL coincide.

d. Column 4, Maintenance Category. Column 4 specifies, by the listing of a "work time" figure in the appropriate subcolumn(s), the lowest level of maintenance authorized to perform the function listed in column 3. This figure represents the active time required to perform that maintenance function at the indicated category of maintenance. If the number or complexity of the tasks within the listed maintenance function vary at different maintenance categories, appropriate "work time" figures will be shown for each category. The number of task-hours specified by the "work time" figure represents the average time required to restore an item (assembly, subassembly, components, module, end item or system) to a serviceable condition under typical field operating conditions. This time includes preparation time, troubleshooting time, and quality assurance/quality control time in addition to the time required to perform the specific tasks indentified for the maintenance function authorized in the maintenance allocation chart. Subcolumns of column 4 are as follows:

- C - Operator/Crew
- O - Organizational
- F - Direct Support
- H - General Support
- D - Depot

e. Columns 5, Tools and Equipment. Column 5 specifies by code, those common tools sets (not individual tools) and special tools, test, and support equipment required to perform the designated function.

f. Column 6, Remarks. Column 6 contains as alphabetic code which leads to the remark in section IV, Remarks, which is pertinent

to the item opposite the particular code.

D-4. Tool and Test Equipment Requirements (Sec III)

a. Tool and Test Equipment Reference Code. The numbers in this column coincide with the numbers used in the tools and equipment column of the MAC. The numbers indicate the applicable tool or test equipment for the maintenance functions.

b. Maintenance Category. The codes in this column indicate the maintenance category allocated the tool or test equipment.

c. Nomenclature. This column lists the noun name and nomenclature of the tools and test functions.

d. National/NATO Stock Number. This column lists the National/NATO Stock Number of the specific tool or test equipment.

e. Tool number. This column lists the manufacturer's part number of the tool followed by the Federal Supply Code for manufacturers (5 digit) in parentheses.

D-5. Remarks (Sec IV)

a. Reference Code. This code refers to the appropriate item in section II, column 6.

b. Remarks. This column provides the required explanatory information necessary to clarify items appearing in section II.

**SECTION II MAINTENANCE ALLOCATION CHART
FOR
SPECTRUM ANALYZER HP8558B**

(1) GROUP NUMBER	(2) COMPONENT ASSEMBLY	(3) MAINTENANCE FUNCTION	(4) MAINTENANCE LEVEL					(5) TOOLS AND EQUIPMENT	(6) REMARKS
			C	O	F	H	D		
00	SPECTRUM ANALYZER HP8558B MTBF= 10,000 Hrs	Inspect				0.1		1-20	B
		Test				3.0			
		Test					3.0	6	A
		Adjust			0.3				
		Calibrate				9.2		1,3-25	B
		Replace			0.1				
		Repair				10.		1,2,6- 20,22- 30	B,C,E D
		Repair					10.		
01	FRONT SWITCH ASSY 08558-60100 A2	Inspect				0.1			
		Test					1.0		
		Replace				0.3		6	
		Repair					4.0		
0101	SWITCH BOARD ASSY 08558-60160 A2A1	Inspect				0.1		6	
		Test					1.0		
		Replace				0.3		6	
		Repair					4.0		
02	FIRST CONVERTER 08558-60004 A4	Inspect				0.1		6	
		Test					1.0		
		Replace				0.3		6	
		Repair					4.0		
03	SECOND CONVERTER 08558-60097 AS	Inspect				0.1		6	
		Test					1.0		
		Replace				0.3		6	
		Repair					4.0		
04	THIRD CONVERTER 08558-60154 A9	Inspect				0.1		6	
		Test					1.0		
		Replace				0.3		6	
		Repair					4.0		
05	BW FILTER NO. 1 08559-60058 All	Inspect				0.1		6	
		Test					1.0		
		Replace				0.3		6	
		Repair					4.0		
06	BW FILTER NO. 2 08558-6019 A13	Inspect				0.1		6	
		Test					1.0		
		Replace				0.3		6	
		Repair					4.0		
07	LOG AMPLIFIER ASSY 5061-5411 A14	Inspect				0.1		6	
		Test					1.0		
		Replace				0.3		6	
		Repair					4.0		
08	MOTHERBOARD ASSY 08558-65159 A16	Inspect				0.1		6	
		Test					2.0		
		Replace				0.5		6	
		Repair					4.0		

**SECTION III. TOOL AND TEST EQUIPMENT REQUIREMENTS
FOR**

SPECTRUM ANALYZER HP8558B

TOOL OR TEST EQUIPMENT REF CODE	MAINTENANCE CATEGORY	NOMENCLATURE	NATIONAL/NATO STOCK NUMBER	TOOL NUMBER
1	H	TRACKING GENERATOR HP8444A	6625-00-185-4802	
2	H	FUNCTION GENERATOR HP3310A	6625-01-028-4989	
3	H	POWER SPLITTER HP11667A	6625-01-017-2713	
4	H	10 dB ATTENUATOR HP8491A	5985-00-128-0195	
5	H	50 ohm TERMINATOR HP908A		
6	F,H	TOOL KIT, ELEC EQUIP TK-105/G	5180-00-610-8177	
7	H	TUNING TOOL 08555-60107		
8	H	ALINEMENT TOOL, MET TIP 8710-0630	5120-01-080-7650	
9	H	ALINEMENT TOOL, PLASTIC 8710-0033	1005-00-634-8012	
10	H	DISPLAY MAINFRAME HP181T		
11	H	FREQUENCY COUNTER HP5342A	6625-01-103-2958	
12	H	DIGITAL VOLTMETER HP3455A	6625-01-874-1000	
13	H	POWER METER HP435A	6625-00-449-9167	
14	H	POWER SENSOR HP8482A		
15	H	AMPLIFIER HP8447D	6625-01-065-0305	
16	H	SIGNAL GENERATOR HP8460	6625-00-318-6304	
17	H	COMB GENERATOR HP8406A	6625-00-937-3525	
18	H	300 MHz LP FILTER TPL300-4AB		
19	H	STEP ATTENUATOR HP355C	5985-00-525-5074	
20	H	STEP ATTENUATOR HP355D	5985-00-957-1860	
21	H	SWEEP OSCILLATOR HP8350A		
22	H	RF PLUGIN HP83522A		
23	H	TIME COUNTER HP5308A	6625-01-022-6231	
24	H	OSCILLOSCOPE HP1741A	6625-01-058-0139	
25	H	CRYSTAL DETECTOR HP423B	6625-01-035-0626	
26	H	SPECTRUM ANALYZER HP141T	6625-00-424-4370	
27	H	BOARD PULLER 03950-4001		
28	H	EXTENDER BOARD, 6 PIN 08559-60042		
29	H	EXTENDER BOARD, 10 PIN 85680-60028	6625-01-137-2674	
30	H	EXTENDER BOARD, 22 PIN 08565-60107		
31	H	EXTENDER CABLE ASSY 5060-0303	5995-01-036-2960	

**SECTION IV. REMARKS
SPECTRUM ANALYZER HP8558B**

REFERENCE CODE	REMARKS
A	Adjustments made when combining units with other subassemblies in display frame.
B	Test, repair, and calibrate by USATSG at general support.
C	Subassemblies A3, A6, A7, A8, A10, A12, A15, A17 and W1 through W6 are throw-aways.
D	Repair consists of replacement of subassemblies and mainframe components as required.
E	A1 is not a replaceable subassembly and has no part number.

D-7/(D-8 blank

By Order of the Secretary of the Army:

Official:

JOHN A. WICKHAM JR.
General, United States Army
Chief of Staff

MILDRED E. HEDBERG
Brigadier General, United States Army
The Adjutant General

Distribution:

To be distributed in accordance with special list.

FRONT PANEL FEATURES

1. VERTICAL POSN: Adjusts vertical position of CRT trace.
2. VERTICAL GAIN: Adjusts deflection circuit gain for amplitude scale calibration of CRT display.
3. FREQUENCY CAL: Removes tuning hysteresis from first LO (YIG oscillator). Should be pressed before calibration and whenever TUNING (22) is changed by more than 50 MHz.
4. FREQUENCY ZERO: Adjusts FREQUENCY MHz (20) readout for calibration on LO feedthrough.
5. BASELINE CLIPPER: Blanks variable lower portion of CRT display. Prevents CRT blooming with a variable persistence storage display mainframe (i.e. 181T/TR).
6. VIDEO FILTER: Post-detection low-pass filter smooths CRT trace by averaging random noise. Filter bandwidth scaled by resolution bandwidth (15) setting. MAX (detent) position selects 1.5 Hz bandwidth for maximum noise averaging and noise level measurements. MAX VIDEO FILTER should **not** be used for CW signal analysis.
7. SWEEP Indicator: Remains lit during each sweep.
8. SWEEP TRIGGER: Selects sweep trigger mode.

VIDEO: Sweep triggered on internal post-detection video waveform. One-half major division of vertical deflection (noise, AM signal, etc.) required to trigger sweep. Normally used with 0 (zero) frequency span for time-domain analysis.

LINE: Sweep triggered at ac line frequency.

FREE RUN: End of each sweep triggers new sweep.

SINGLE: Single sweep triggered or reset by turning SWEEP TRIGGER clockwise momentarily.

9. 1st LO OUTPUT: 50-ohm BNC output provides 2.05-3.55 GHz first LO signal at approximately + 10 dBm. Terminate with 50ohm load when not in use.
10. INPUT 50f: Precision type N (female) signal input connector with 50-ohm input impedance.
Options 001 and 002: INPUT 75f- 75-ohm BNC (female) signal input connector.

CAUTION

50-ohm BNC connectors might cause damage if used directly with Option 001 and 002 75-ohm BNC INPUT and CAL OUTPUT connectors.

11. SWEEP TIME/DIV: Selects time required to sweep one major horizontal division on CRT.

AUTO: Automatically selects fastest allowable sweep time as a function of FREQ SPAN/DIV (13), RESOLUTION BW (15), and VIDEO FILTER (6) settings to maintain display amplitude calibration. AUTO operation retained with FREQ SPAN/DIV and RESOLUTION BW controls uncoupled.

TIME/DIV: Selects calibrated sweep time; used primarily with 0 (Zero) frequency span for time-domain analysis of modulation waveforms. Display amplitude calibration not automatically guaranteed for other frequency spans.

MAN: Enables manual frequency scan using MAN SWEEP knob.

12. PROBE POWER: Provides power for high-impedance active probes such as the HP 1121A. (See Section I of HP 8558B Operation and Service Manual for details regarding use with Options 001 and 002.)
13. FREQ SPAN/DIV: Selects CRT horizontal axis frequency calibration.

MHz/DIV kHz/DIV: Selects desired frequency span. Alignment of OPTIMUM markings (><) selects optimum resolution bandwidth (15).

0 (Zero Span): Spectrum analyzer operates as a manually-tuned receiver, at frequency indicated by FREQUENCY MHz readout, for time-domain display of signal modulation. 16 calibrated sweep times selectable with SWEEP TIME/DIV control (11).

14. REF LEVEL CAL: Adjusts spectrum analyzer RF gain to calibrate top CRT graticule line for absolute amplitude measurements.

15. RESOLUTION BW: Selects spectrum analyzer 3-dB bandwidth. Alignment of OPTIMUM markings (> <) automatically selects optimum resolution bandwidth for any frequency span. Control pushed in to couple mechanically with FREQ SPAN/DIV.

16. CAL OUTPUT: BNC output provides 280 MHz, -30 dBm calibration signal from 50f output impedance.

Option 001: 280 MHz, -30 dBm calibration signal from 759 output impedance.
Option 002: 280 MHz, + 20 dBmV calibration signal from 752 output impedance.

CAUTION

50-ohm BNC connectors might cause damage if used directly with Option 001 and 002 75-ohm BNC INPUT and CAL OUTPUT connectors.

17. 10 dB/DIV - dB/DIV - LIN (Amplitude Scale): Selects CRT vertical axis amplitude calibration (logarithmic or linear scale). Reference Level remains constant at top CRT graticule line.

18. REFERENCE LEVEL: Adjusts' power level (in dBm or dBmV) represented |by top CRT graticule line. Large outer knob provides adjustment in calibrated 10-dB steps; FINE vernier provides 12 dB of continuous adjustment.

19. INPUT ATTEN: Selects desired RF input attenuation, indicated by blue numbers (push and turn).

20. FREQUENCY MHz: Displays spectrum analyzer start or center frequency. Automatically ranges at approximately

195 MHz for increased resolution at lower frequencies.

21. START-CENTER: Selects mode of FREQUENCY MHz (20) readout.

22. TUNING: Adjusts spectrum analyzer start or center frequency. Coarse tuning is provided by large knob; smaller knob provides FINE tuning.

180-Series Display Mainframes

23. CALIBRATOR (180TR, 182T): Provides 1 kHz square wave at two amplitudes: 250 mV and 10V p-p (not used with spectrum analyzer).

24. Ground Connection (180TR, 182T): Provides chassis ground connection point.

25. SCALE (180TR, 182T): Adjusts CRT graticule illumination.

26. TRACE ALIGN: Adjusts CRT trace alignment with horizontal graticule lines.

27. FOCUS: Adjusts CRT trace sharpness.

28. ASTIG: Adjusts CRT spot shape.

29. INTENSITY: Adjusts CRT trace intensity.

30. FIND BEAM: Intensifies trace and forces on-screen display (normally not used with spectrum analyzer).

31. HORIZONTAL POSITION: Single knob provides coarse and fine horizontal adjustment of CRT trace.

32. MAGNIFIER: Selects horizontal deflection factor adjustment for external CRT sweep signals.

33. DISPLAY: Selects CRT sweep source (normally left in INT position).

34. EXT VERNIER: Provides continuous deflection factor adjustment for external CRT sweep signals. In CAL detent position, deflection factor is selected by MAGNIFIER (32) control (normally not used with spectrum analyzer).

35. EXT COUP 3-5 ts EXT INPUT (36) ac or dc coupling (normally not used with spectrum analyzer).

36. EXT INPUT: BNC input for external CRT sweep signal (normally not used with spectrum analyzer).

NOTE

HORIZONTAL EXT INPUT does not sweep the spectrum analyzer first LO. Analyzer should be set to 0 (zero) FREQ SPAN/DIV, AUTO TIMEIDIV, and SINGLE SWEEP TRIGGER- when operated with an external horizontal input.

37. Switch with indicator light for turning power ON and OFF.

NOTE

See Appendix A for details regarding HP 181TTR Variable Persistence Storage Display Mainframes.



HP 8558B Front Panel, Option 001



HP 8558B Front Panel, Option 002

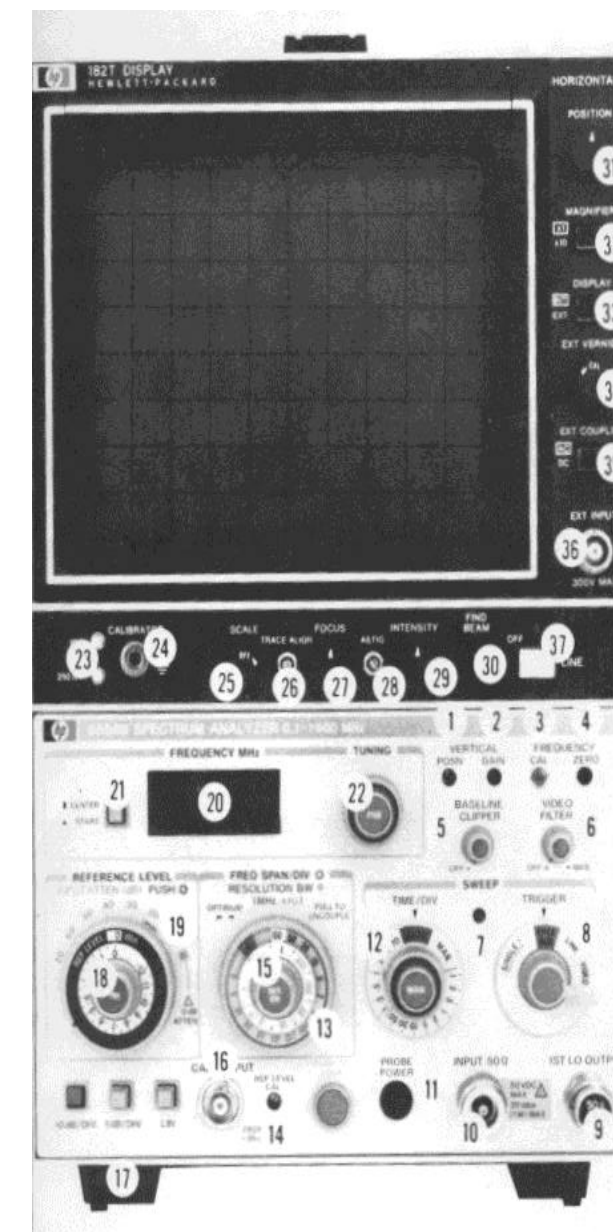

Figure 3-1. HP 8558B Installed in HP 182T Display Mainframe

REAR PANEL FEATURES

1. P1 Connector: Connects spectrum analyzer plug-in to display mainframe.
2. HORIZ GAIN: Allows $\pm 1/2$ major division of horizontal gain adjustment to calibrate spectrum analyzer plug-in with display mainframe.
3. AUX A Vertical Output: BNC output provides detected video signal from a 50-ohm output impedance. Typical 0-800 mV range corresponds to full 8-division display deflection.
4. AUX B PENLIFT/BLANKING OUTPUT: BNC output provides a + 15V penlift/blanking signal from a 10K-ohm output impedance when CRT trace is blanked. Otherwise, output is low at 0V (low impedance, 150 mA max.) for an unblanked trace.
5. AUX C 21.4 MHz IF OUTPUT: BNC output provides 21.4 MHz IF signal (linearly related to spectrum analyzer RF input) from a 50-ohm output impedance. Output bandwidth controlled by spectrum analyzer RESOLUTION BW setting; output amplitude controlled by INPUT ATTEN, REFERENCE LEVEL FINE, and first six REFERENCE LEVEL positions (i.e., with 0 dB input attenuation, - 10 through -60 dBm; for Option 002, + 40 through - 10 dBmV).
6. AUX D Horizontal Output: BNC output provides horizontal sweep voltage from a 5Kohm output impedance. -5V to + 5V range corresponds to full 10-division display deflection.
7. Z-Axis Input: BNC input with a 5K-ohm impedance allows external modulation of CRT trace intensity. Approximately + 2V blanks normal-intensity trace; negative voltage increases trace intensity. Maximum input voltage ± 20 Vdc.
8. NORMALIZER INTER-CONN (180TR/182T): Provides connections for HP 8750A Storage Normalizer.

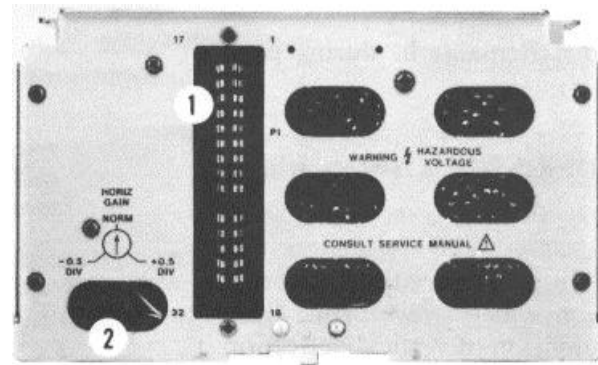

Figure 3-2. Rear Panel Controls and Connectors (1 of 2)

Reference Designation	HP Part Number	C D	Qty	Description	Mfr. Code	Mfr Part Number
MECHANICAL CHASSIS PARTS						
NOTE						
COMPLETE FRONT PANEL ASSEMBLIES (LISTED BELOW) INCLUDE A2 FRONT SWITCH ASSY, PANEL, ALL KNOBS, & PROBE POWER INPUT, CAL OUTPUT, AND LO OUTPUT CABLES						
	08558-60161	5	1	FRONT PANEL ASSY (STD.)	28480	08558-60161
	08558-60164	8		FRONT PANEL ASSY (OPT. 001)	28480	08558-60164
	08558-60165	9	1	FRONT PANEL ASSY (OPT. 002)	28480	08558-60165
1	08558-00114	2	1	PANEL-FRONT (STD.)	28480	08558-00114
1	08558-00121	1	1	PANEL-FRONT (OPT.001)	28480	08558-00121
1	08558-00122	2	1	PANEL-FRONT (OPT.002)	28480	08558-00122
2	08558-00116	4	1	SIDE GUSSET (LEFT)	28480	08558-00116
3	08558-00115	3	1	SIDE GUSSET (RIGHT)	28480	08558-00115
4	08558-00003	8	1	PANEL (REAR)	28480	08558-00003
5	5061-5426	9	1	GUIDE RAIL (TOP)	28480	5061-5426
6	08565-20093	7	4	EXTRUSION, CIRCUIT ENCLOSURE, TAPPED	28480	08565-20093
7	08558-20037	0	1	EXTRUSION, END PLATE ENCLOSURE	28480	08558-20037
8	08558-20036	9	4	EXTRUSION, CIRCUIT ENCLOSURE, TAPPED	28480	08558-20036
9	08565-20051	7	1	EXTRUSION, CIRCUIT ENCLOSURE	28480	08565-20051
10	08558-20038	1	1	EXTRUSION, ENCLOSURE DIVIDER	28480	08558-20038
11	08565-20096	0	8	EXTRUSION, CIRCUIT ENCLOSURE, TAPPED	28480	08565-20096
12	5021-3229	2	1	WINDOW, FREQ. DISPLAY (GLUED TO 1)	28480	5021-3229
13	08558-00030	1	1	INSULATOR-GUIDE RAIL (BOTTOM)	28480	08558-00030
14	08558-20164	4	1	GUIDE RAIL (BOTTOM)	28480	08558-20164
15	08557-60045	3	1	CABLE ASSY (W10) VERTICAL OUTPUT	28480	08557-60045
16	2200-0165	6	2	SCREW-MACH 4-40 .25-IN-LG 82 DEG	28480	2200-0165
17	2360-0194	9	4	SCREW-MACH 6-32 .312-IN-LG 100 DEG	28480	2360-0194
18	2200-0104	3	6	SCREW-MACH 4-40 .25-IN-LG 82 DEG	28480	2200-0104
19	2360-0201	9	2	SCREW-MACH 6-32 .5-IN-LG PAN-HD-POZI	28480	2360-0201
20	0624-0099	1	81	SCREW-TPG 4-40 .375-IN-LG PAN-HD-POZI	28480	0624-0099
21	0624-0206	2	1	SCREW-TPG 6-32 .25-IN-LG PAN-HD-POZI	28480	0624-0206
22	2200-0103	2	12	SCREW-MACH 440 .25-IN-LG PAN-HD-POZI	28480	2200-0103
23	2360-0115	4	3	SCREW-MACH 6-32 .312-IN-LG PAN-HD-POZI	28480	2360-0115
24	2200-0170	3	1	SCREW-MACH 440 .625-IN-LG 82 DEG	28480	2200-0170
25	0380-0005	1	1	SPACER-RND .312 IN-LG .18-IN-ID	28480	0380-0005
26	2260-0003	7	1	NUT-HEX-PLSTC LKG 4-40-THD .141-IN-THK	28480	2260-0003
27	2200-0105	4	6	SCREW-MACH 4-40 .312-IN-LG PAN-HD-POZI	28480	2200-0105
28	2200-0164	5	2	SCREW-MACH 4-40 .188-IN-LG UNCT 82 DEG	28480	2200-0164
29	2200-0168	9	3	SCREW-MACH 4-40 .438-IN-LG 82 DEG	28480	2200-0168
30	08558-00108	4	1	COVER-LOG AMPLIFIER	28480	08558-00108
31	08558-00089	0	1	COVER-BANDWIDTH FILTER NO. 1	28480	08558-00089
32	08558-00088	9	1	COVER-STEP GAIN	28480	08558-00088
33	08558-00087	8	1	COVER-BANDWIDTH FILTER NO. 2	28480	08558-00087
34	0380-0005	1	1	SPACER-RND .312 IN-LG .18-IN-ID	28480	0380-0005
35	3050-0105	6	4	WASHER-FL MTLG NO. 4 .125-IN-ID	28480	3050-0105
36	1400-0082	9	2	CLAMP-CABLE .125-IDIA .375-WD NYL	28480	1400-0082
37	2420-0001	5	2	NUT-HEX-W/LKWR 6-32-THD .109-IN-THK	28480	2420-0001
38	2190-0016	3	2	WASHER-LK INTL T 3/8 IN .377-IN-ID	28480	2190-0016
39	2950-0043	8	1	NUT-HEX-DBL-CHAM 3/8-32-THD .094-IN-THK	28480	2950-0043
40	2190-0068	5	1	1 WASHER-LK INTL T 1/2 IN .505-IN-ID	28480	2190-0068
41	2950-0054	1	1	NUT-HEX-DBL-CHAM 1/2-28-THD .125-IN-THK	28480	2950-0054
42	0370-0606	7	4	BEZEL-PB .330-IN-SQ;JADE GRAY	28480	0370-0606
43	5040-8817	4	3	PUSHBUTTON-SQUARE; JADE GRAY	28480	5040-8817
44	08565-40011	1	1	POINTER-INPUT ATTENUATOR	28480	08565-40011
45	1460-0532	0	1	SPRING-CONICAL	28480	1460-0532
46	08558-60166	0	1	KNOB ASSY-REFERENCE LEVEL (OPT. 002)	28480	08558-60166
46	08558-60167	1	1	KNOB ASSY-REFERENCE LEVEL (STD. OPT. 001)	28480	08558-60167
47	08558-00123	3	1	INDEX DISK (OPT. 002) REFERENCE LEVEL	28480	08558-00123
47	08565-00043	5	1	INDEX DISK (STD. OPT. 001) REFERENCE LEVEL	28480	08565-00043
48	0510-0089	8	1	RETAINER-RING BSC EXT .188-IN-DIA BE-CU	28480	0510-0089
49	08565-60047	5	1	KNOB ASSY, REF. LEVEL (FINE)	28480	08565-60047
50	08558-20161	1	1	KNOB ASSY, RESOLUTION BW	28480	08558-20161
51	08558-20162	2	1	KNOB ASSY, FREQ. SPAN/DIV	28480	08558-20162
52	5040-8819	6	1	PUSHBUTTON-SQUARE, WILLOW GREEN	28480	5040-8819
53	0590-1251	6	2	NUT-SPCLY 15/32-32-THD .1-IN-THK .562-WD	28480	0590-1251
54	0370-1121	3	1	KNOB-LOCK	28480	0370-1121
55	08558-60170	6	1	CABLE ASSY-PROBE POWER (W16)	28480	08558-60170
56	08558-60031	8	1	CABLE ASSY-75 OHM INPUT (W1) OPT. 001, 002	28480	08558-60031
56	08558-60038	5	1	CABLE ASSY-50 OHM INPUT (W1) STD. SEE FIG 6-1	28480	08558-60038
57	0370-3021	6	1	KNOB ASSY-MANUAL SWEEP	28480	0370-3021
58	08558-20163	3	1	KNOB ASSY-SWEEP TIME/DIV	28480	08558-20163
59	08559-20050	8	1	KNOB ASSY-SWEEP TRIGGER	28480	08559-20050
60	0370-3006	7	1	KNOB ASSY-FINE TUNE	28480	0370-3006
61	0370-3004	5	1	KNOB ASSY-COARSE TUNE	28480	0370-3004
62	08565-60170	5	2	KNOB-BASELINE CLIP/VIDEO FILTER	28480	08565-60170
63*	2190-0390	6	1	WASHER-FL NM 1/4 IN .26-IN-ID .562-IN-OD	28480	2190-0390
64	2950-0001	8	1	NUT-HEX-DBL-CHAM 3/8-32-THD .094-IN-THK	28480	2950-0001
65	2200-0119	0	2	SCREW-MACH 440 1-IN-LG PAN-HD-POZI	28480	2200-0119
66*	3050-0929	2	1	WASHER-FL NM 1/4 IN .26-IN-ID .562-IN-OD (SHIM WASHER, NOT SHOWN, USED WITH 63 FOR PROPER SPACING BETWEEN 46 AND 47.)	28480	3050-0929

7-2. Front Panel Assembly (2 of 3) (CHANGE A)

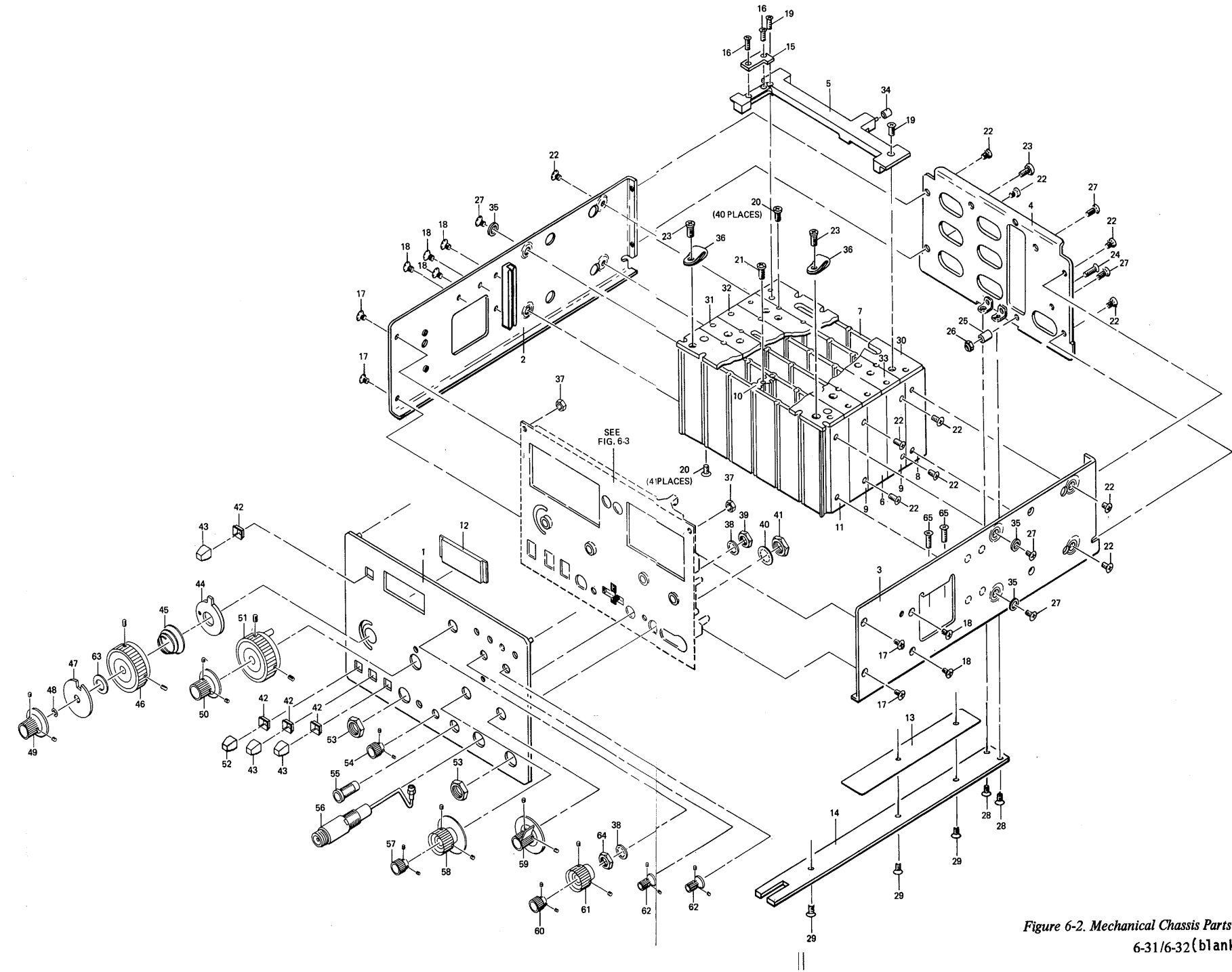

Figure 6-2. Mechanical Chassis Parts
6-31/6-32 (blank)

Figure 6-2. Mechanical Chassis Parts

Reference Designation	HP Part Number	C	D	Qty	Description	Mfr. Code	Mfr Part Number
A2	08558-60100	2	1	1	FRONT SWITCH ASSEMBLY (MECH PARTS) NOTE SEE A2 FRONT SWITCH ASSY LISTING FOR ELECTRICAL PARTS; SEE FIG 6-2 FOR FRONT PANEL PARTS	28480	08558-60100
1	5021-3213	4	1	1	DIECAST-FRONT SWITCH	28480	5021-3213
2	1460-0012	1	1	1	SPRING-CPRSN .135-IN-OD .688-IN-OA-LG	28480	1460-0012
3	5021-3227	0	1	1	SHAFT-LOCKING	28480	5021-3227
4	1480-0017	8	1	1	PIN-DOWEL .125 OD	28480	1480-0017
5	5001-5818	7	1	1	LINK-LOCKING	28480	5001-5818
6	5021-3218	9	1	1	SHAFT-REF LEVEL	28480	5021-3218
7	08559-60060	4	2	2	HUB ASSEMBLY-DRIVE, ANTI-CRUSH	28480	08559-60060
8	08558-60098	7	1	1	ROTOR-ATTENUATOR DRIVE	28480	08558-60098
9	5021-3224	7	1	1	SHAFT-FREQUENCY SPAN	28480	5021-3224
10	1410-0006	8	7	7	BALL-BRG TYPE .1875-DIA GRADE-50 SST	78707	GRADE 50
11	1460-0623	0	3	3	SPRING-COMPRESSION .18-IN-OD .312-IN-OA-L	28480	1460-0623
12	1480-0059	8	11	11	PIN-ROLL	28480	1480-0059
13	08558-20066	5	1	1	ROTOR-FREQUENCY SPAN	28480	08558-20066
14	08558-20059	6	2	2	HUB-DRIVE	28480	08558-20059
15	08558-20089	2	1	1	BUSHING-SLOTTED	28480	08558-20089
16	1460-1376	2	1	1	SPRING-HAIRPIN	28480	1460-1376
17	5061-5424	7	1	1	SHAFT ASSEMBLY-ATTENUATOR	28480	5061-54240
18	3050-0032	8	1	1	WASHER-FL MTL NO. 8 .189-IN-ID	28480	3050-0032
19	2200-0105	4	7	7	SCREW-MACH 4-40 .312-IN-LG PAN-HD-POZI	28480	2200-0105
20	5001-5813	2	1	1	BRACKET-LEFT DPM MOUNTING	28480	5001-5813
21	5001-5814	3	1	1	BRACKET-RIGHT DPM MOUNTING	28480	5001-5814
22	2260-0009	3	4	4	NUT-HEX-W/LKWR 4-40-THD .094-IN-THK	28480	2260-0009
23	2200-0111	2	1	1	SCREW-MACH 4-40.5-IN-LG PAN-HD-POZI	28480	2200-0111
24	0380-0034	6	1	1	SPACER-RND .312-IN-LG .116-IN-ID	28480	0380-0034
25	0510-0015	0	5	5	RETAINER-RING E-R EXT.125-IN-DIA STL	28480	0510-0015
26	5021-3226	9	1	1	SHAFT-MANUAL SWEEP	28480	5021-3226
27	1460-0578	4	2	2	SPRING-COMPRESSION	28480	1460-0578
28	5061-5425	8	2	2	ROTOR/SHAFT ASSEMBLY, DOUBLE CONTACT	28480	5061-5425
29	0510-0027	4	1	1	RETAINER-PUSH ON	28480	0510-0027
30	08558-00053	8	1	1	STOP ARM	28480	08558-00053
31	1460-0537	5	1	1	SPRING-HORSESHOE	28480	1460-0537
32	2950-0001	8	4	4	NUT-HEX-DBL-CHAM 3/8-32-THD .094-IN-THK	28480	2950-0001
33	2190-0016	3	4	4	WASHER-LK INTL T 3/8 IN .377-IN-ID	28480	2190-0016
34	08558-40007	6	1	1	KNOB-FREQ. ZERO	28480	08558-40007
35	2190-0067	4	3	3	WASHER-LK INTL T 1/4 IN .256-IN-ID	28480	2190-0067
36	2950-0006	3	3	3	NUT-HEX-DBL-CHAM 1/4-32-THD .094-IN-THK	28480	2950-0006
37	2100-3066	0	1	1	RESISTOR-VAR 5K 5% PREC WW (A2R3) FREQ.	28480	2100-3066
38	3050-0028	2	1	1	WASHER-FL MTL NO. 12 .25-IN-ID	28480	3050-0028
39	2100-3973	8	1	1	RESISTOR-VAR 50K 20% 5W(VIDEO FILTER)	28480	2100-3973
40	08558-20114	4	1	1	SHAFT-FINE TUNE	28480	08558-20114
41	08558-20113	3	1	1	SHAFT-COARSE TUNE	28480	08558-20113
42	08559-20040	6	1	1	BUSHING-COARSE TUNE SHAFT	28480	08559-20040
43	1430-0568	9	1	1	GEAR-SPUR, 40T	28480	1430-0568
44	1460-1542	4	1	1	SPRING-UNIVERSAL COUPLER	28480	1460-1542
45	5001-5825	6	1	1	BRACKET-DUAL POT	28480	5001-5825
46	2100-3452	8	1	1	RESISTOR-VAR PREC W/CP 10-TRN 10K 10%	28480	2100-3452
47	2100-3593	8	1	1	RESISTOR-VAR PREC W/CP 10-TRN 5K 10%	28480	2100-3593
48	1430-0567	8	1	1	GEAR-SPUR, 60T	28480	1430-0567
49	2190-0390	6	1	1	WASHER-FL NM 1/4 IN .26-IN-ID .562-IN-OD	28480	2190-0390
50	3050-0086	2	1	1	WASHER-FL MTL 3/8 IN .406-IN-ID	28480	3050-0086
51	1460-0019	8	1	1	SPRING-COMPRESSION	28480	1460-0019
52	08558-60168	2	1	1	CABLE ASSY, DPM RIBBON (A2A1W1) (P/O A2A1)	28480	08558-60168
53	08558-60171	7	1	1	CABLE ASSY, INT RIBBON (A2A1W2) (P/O A2A1)	28480	08558-60171
54	2200-0103	2	8	8	SCREW-MACH 4-40 .25-IN-LG PAN-HD-POZI	28480	2200-0103
55	5001-5817	6	1	1	BRACKET-ATTENUATOR	28480	5001-5817
56	3050-0105	6	1	1	WASHER-FL MTL NO. 4 .125-IN-ID	28480	3050-0105
57	1430-0036	6	2	2	GEAR-MIT 16-T 32-DP 20-DG PA BRS	71041	G462Y(MOD)
58	5001-5816	5	1	1	DETENT-BANDWIDTH	28480	5001-5816
59	5021-3220	3	5	5	STUD-500-IN-LG, 4-40 THD	28480	5021-3220
60	08558-20058	5	1	1	HUB-COUPLING	28480	08558-20058
61	5021-3225	8	1	1	SHAFT-BANDWIDTH	28480	5021-3225
62	1460-1860	9	2	2	SPRING-CPRSN .18-IN-OD	92830	C0180-014-0310-S
63	08558-40004	3	1	1	ROTOR-SINGLE CONTACT	28480	08558-40004
64	08558-20139	3	1	1	SPACER-ROTOR	28480	08558-20139
65	2100-3332	3	1	1	RESISTOR-TRMR 10K 20% CC 1-TRN(A2A1R4)	28480	2100-3332
66	08558-20030	3	1	1	BOARD-BANDWIDTH SWITCH (P/O A2A1)	28480	08558-20030
67	08558-40005	4	1	1	ROTOR-DOUBLE CONTACT	28480	08558-40005
68	5061-5423	6	1	1	DETENT-REF. LEVEL	28480	5061-5423
69	5021-3221	4	3	3	STANDOFF-1 .438-1N-LG 4-40 THD	28480	5021-3221
70	08558-20061	0	1	1	LOCKOUT-ROTATING	28480	08558-20061
71	5061-5422	5	1	1	LOCATOR-INDEX DISC	28480	5061-5422
72	5021-3217	8	1	1	SHAFT-REF. LEVEL (FINE)	28480	5021-3217
73	1490-0841	7	1	1	COUPLING-RGD .375-LG BRS	28480	1490-0841
74	3050-0080	6	1	1	WASHER-FL NM NO. 5 .13-IN-ID .25-IN-OD	28480	3050-0080
75	08558-00021	0	1	1	PLATE-REF. LEVEL, FINE POT	28480	08558-00021
76	2100-0542	1	1	1	RESISTOR-VAR CONTROL WW 10K 5% LIN	28480	2100-0542
77	3050-0017	9	1	1	WASHER-FL MTL .25-IN-ID	28480	3050-0017

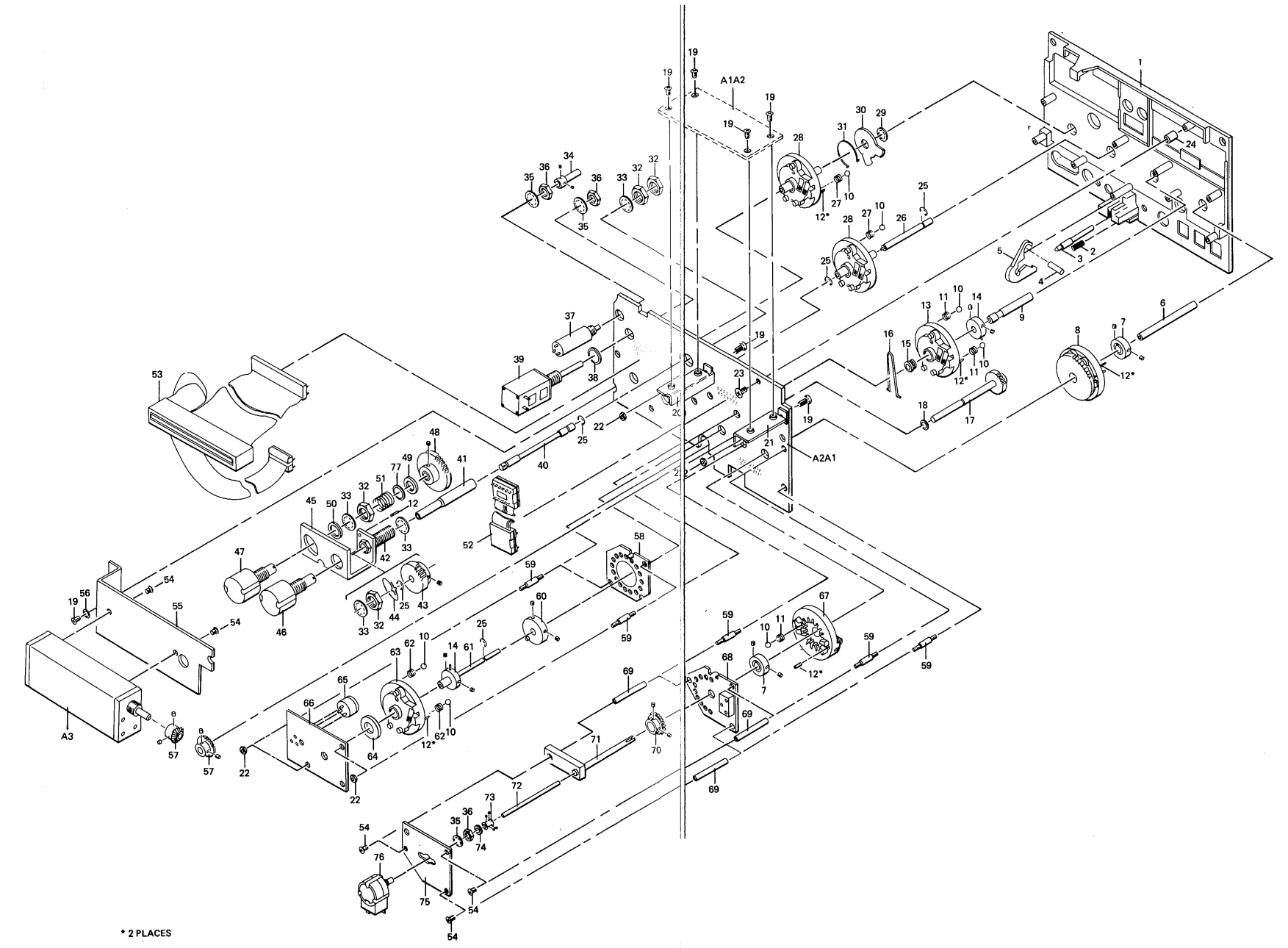

Figure 6-3. Front Switch Assembly

Reference Designation	HP Part Number	C D	Qty	Description	Mfr. Code	Mfr Part Number
73	2260-0001	5	2	NUT-HEX-DBL-CHAM 4-40	28480	2260-0001
74	08558-20056	3	1	SHAFT, BANDWIDTH	28480	08558-20056
75	08558-20058	5	1	HUB, COUPLING	28480	08558-20058
76	2190-0102	8	1	WASHER-LK INTL T-15/32 IN .472-IN-ID	28480	2190-0102
77	3050-0124	9	2	WASHER-FL MTLC NO. 5 .13-IN-ID	28480	3050-0124
78	08558-20055	2	1	SHAFT, MANUAL SWEEP	28480	08558-20055
79	3030-0332	9	2	SCREW-SET 2-56 .094-IN-LG CUP-PT SST	28480	3030-0332
80	08558-40007	6	1	KNOB, KNURLED	28480	08558-40007
81	2950-0142	8	1	NUT-HEX-DBL-CHAM 3/8-32-THD .635-IN-THX	28480	2950-0142
82	08558-20049	4	1	SHAFT, SWEEP TIME	28480	08558-20049
83	2200-0151	6	1	WASHER-FL NM 1/4 IN .26-IN-ID .562-IN-OD	28480	2190-0390
84	08558-20048	3	1	SHAFT, SWEEP TRIGGER	28480	08558-20048
85	1460-0537	5	1	SPRING-TRSN MUW CD	28480	1460-0537
86	08558-00053	8	1	STOP ARM	28480	08558-00053
87	08558-00026	5	1	DETENT, SWEEP TRIGGER	28480	08558-00026
88	2200-0151	0	4	SCREW-MACH 4-40 .75-IN-LG PAN-HD-POZI	28480	2200-0151
89	2950-0054	1	1	NUT-HEX-DBL-CHAM 1/2-28-THD .125-IN-THX	28480	2950-0054
90	2190-0068	5	1	WASHER-LK INTL T 1/2 IN .505-IN-ID	28480	2190-0068
91	2200-0155	4	1	SCRE-MACH 4-40 1-IN-1LG PAN-HD-POZI	28480	2200-0155
92	08558-20071	2	2	CABLE, LO OUTPUT	28480	08558-20071
93	08558-20092	7	1	SHAFT, LATCH	28480	08558-20092
94	08558-00082	3	1	PANEL, FRONT (SEE FIG. 6-2 FOR SUB-PANEL)	28480	08558-00082
94	08558-00083	4	1	PANEL, FRONT (OPTION 001)	28480	08558-00083
94	08558-00084	5	1	PANEL, FRONT (OPTION 002)	28480	08558-00084
95	2950-0072	3	1	NUT-HEX-DBL-CHAM 1/4-32-THD .062-IN-THK	28480	2950-0072
96	3101-0044	1	2	SWITCH-PB SPST-NO MOM .5A 115VAC RED-BTN	28480	3101-0044
97	00183-67407	7	2	KNOB	28480	00183-67407
98	0510-0045	6	1	RETAINER-RING F-R EXT .188-IN-DIA STL	28480	0510-0045
99	0590-0012	5	2	NUT-KNRLD-R 15/32-32-THD .062-IN-THK	28480	0590-0012
100	08558-20093	8	1	KNOB, LATCH	28480	08558-20093
101	08558-00045	8	1	KNOB, MANUAL SWEEP	28480	08558-00045
102	08558-00044	7	1	KNOB, SWEEP TIME	28480	08558-00044
103	5060-0467	6	1	CONNECTOR, MALE, PROBE POWER	28480	5060-0467
104	08558-60038	5	1	CABLE ASSY, INPUT, RF	28480	08558-60038
104	08558-60031	8	1	CABLE ASSY, 75 OHM INPUT, RF	28480	08558-60031
105	08558-00107	3	1	KNOB, TRIGGER SWITCH	28480	08558-00107
106	0380-0063	1	1	SPACER-RND .125-IN-LG .129-IN-ID	28480	0380-0063
107	1430-0567	8	1	GEAR, SPUR, 60 T	28480	1430-0567
108	1430-0568	9	1	GEAR, SPUR, 40 T	28480	1430-0568
109	1460-1542	4	1	SPRING, UNIVERSAL COUPLER	28480	1460-1542
110	3050-0086	2	2	WASHER-FL MTLC 3/8 IN .406-IN-ID	28480	3050-0086
111	08558-00069	6	1	SPRING	28480	08558-00069
112	08558-00070	9	1	BRACKET, DUAL POT	28480	08558-00070
113	08558-20111	1	1	BUSHING, COARSE TUNE SHAFT	28480	08558-20111
114	08558-20112	2	1	WASHER, THRUSH	28480	08558-20112
115	08558-20113	3	1	SHAFT, COARSE TUNE	28480	08558-20113
116	08558-20114	4	1	SHAFT, FINE TUNE	28480	08558-20114
117	1460-0623	0	1	SPRING-CPRSN .18-IN-OD .312-IN-OA-LG MUW	28480	1460-0623
118	2200-0165	6	1	SCREW-MACH 4-40 .25-IN-LG 82 DEG	28480	2200-0165
119	6960-0016	0	1	PLUG-HOLE TR-HD FOR .125-D-HOLE NYL	28480	6960-0016
120	2200-0121	4	1	SCREW-MACH 4-40 1.1258-IN-LG PAN-HD-POZI	28480	2200-0121
121	2190-0004	9	1	WASHER-LK INTL T NO. 6 .115-IN-ID	28480	2190-0004
122	2950-0001	8	1	NUT-HEX-DBL-CHAM 3/8-32-THD .094-IN-THK	28480	2950-0001
123	7120-7136	0	1	LABEL, HP LOGO	28480	7120-7136

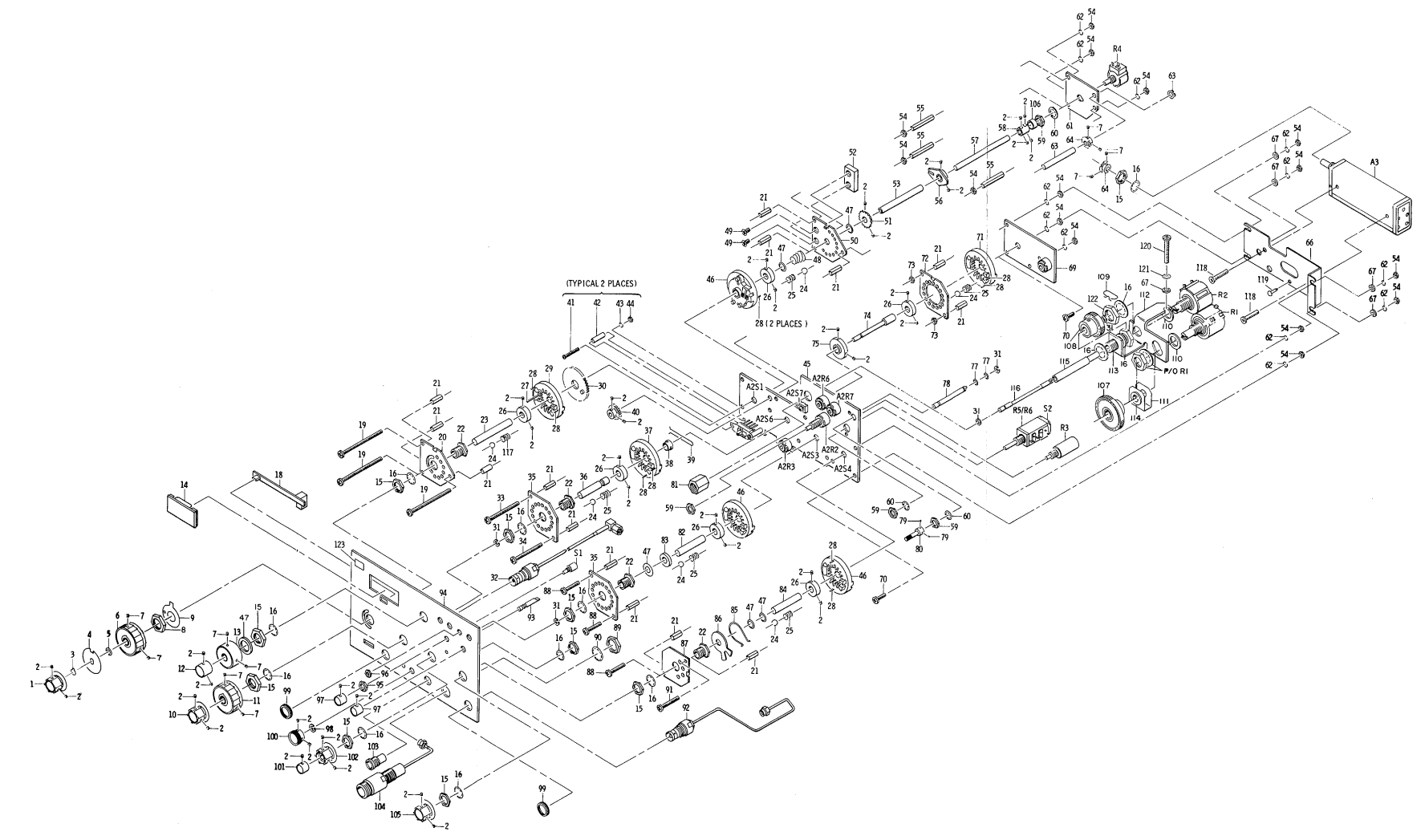
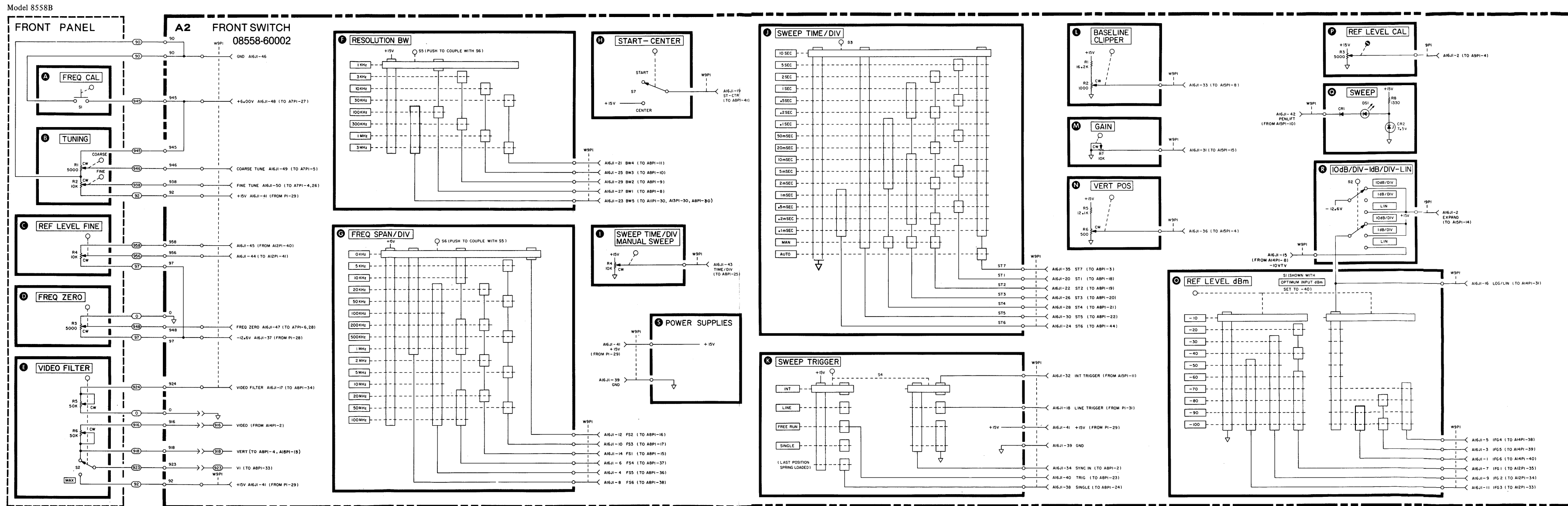

Figure 7-2. Front Panel Assembly (3 of 3) (CHANGE A)

Figure 7-2. Front Panel Assembly (2 of 3) (CHANGE A)



- NOTES**
- EXCEPT FOR W9 INTERCONNECT CABLE ASSY, REFERENCE DESIGNATORS WITHIN THIS ASSEMBLY ARE ABBREVIATED. PREFIX ABBREVIATION WITH ASSEMBLY NUMBER FOR COMPLETE REFERENCE DESIGNATOR.
 - UNLESS OTHERWISE INDICATED: RESISTANCE IN OHMS (Ω) CAPACITANCE IN MICROFARADS (μ F) INDUCTANCE IN MICROHENRIES (μ H)
 - MNEMONIC TABLE:
- | MNEMONIC | DEFINITION |
|----------|---|
| BW1-5 | BANDWIDTH CONTROL LINES |
| FS1-6 | FREQUENCY SPAN CONTROL LINES |
| IFG1-6 | IF GAIN CONTROL LINES |
| ST1-6 | SCAN TIME CONTROL LINES (S16 ENABLES FAST SCAN TIMES) |
| ST - CTR | START - CENTER |
| -10 VTV | -10V TEMP VARIABLES |

Figure 7-3. Front Switch Assembly A2, Schematic (CHANGE A)

7-13/7-14 (blank)

A2

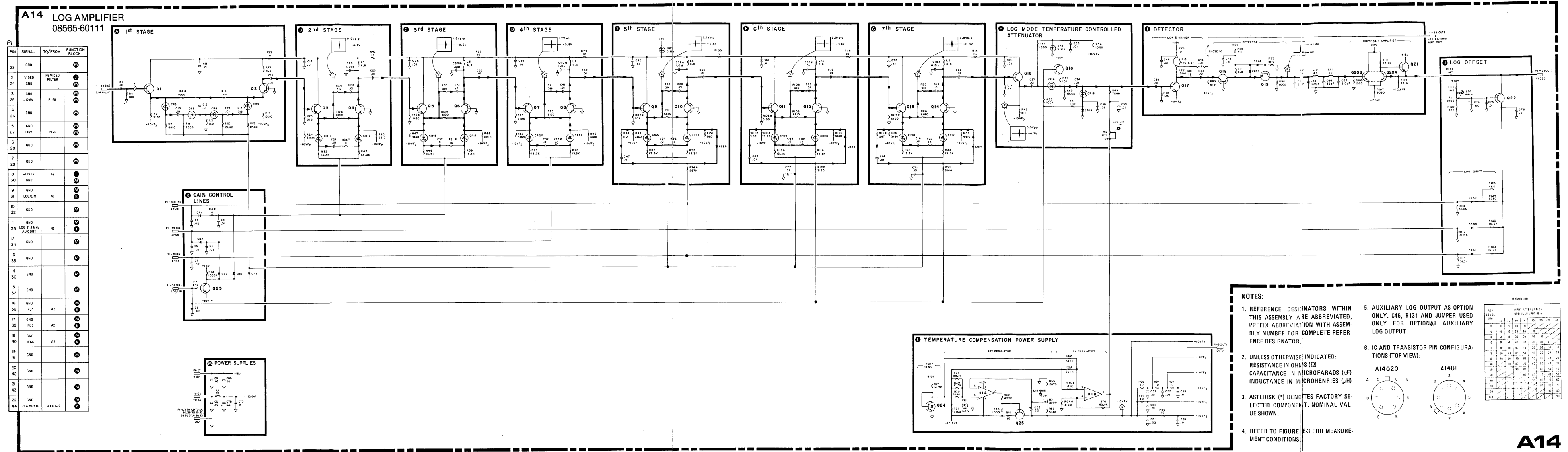

Figure 7-6. A14 Log Amplifier Assembly Schematic (CHANGE B)

7-25/7-26 (blank)

A14

DPM DRIVER
1558-60125

P/O A2A1 FRONT SWITCH BOARD ASSEMBLY
08558-60110

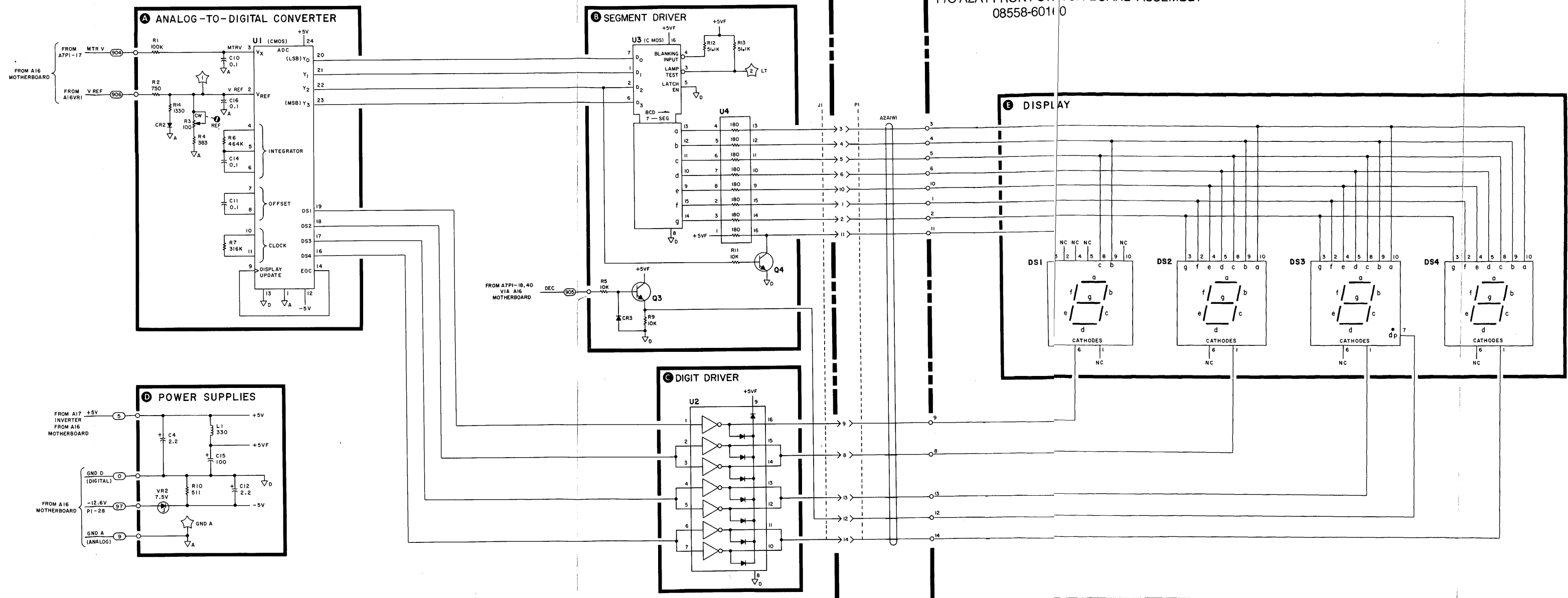

NOTES

1. REFERENCE DESIGNATORS WITHIN THIS ASSEMBLY ARE ABBREVIATED. PREFIX ABBREVIATION WITH ASSEMBLY NUMBER FOR COMPLETE REFERENCE DESIGNATOR.
2. UNLESS OTHERWISE INDICATED: RESISTANCE IN OHMS (Ω) CAPACITANCE IN MICROFARADS (μF) INDUCTANCE IN MICROHENRIES (μH)
3. REFER TO FIGURE 8-2 FOR MEASUREMENT CONDITIONS.
4. MNEMONIC TABLE:

MNEMONIC	DEFINITION
DEC	DECIMAL POINT LINE (LOW-OFF)
GND A	DPM ANALOG GROUND
GND D	DPM DIGITAL GROUND
LT	LAMP TEST (GND=TEST)
MTR V	DPM VOLTAGE
V REF	DPM REFERENCE VOLTAGE

FOR COMPLETE LIST OF SIGNAL NAMES AND MNEMONICS, SEE A16 MOTHERBOARD SCHEMATIC.

A1A2

Figure 8-11. A1A2 DPM Driver (and DPM Display), Schematic

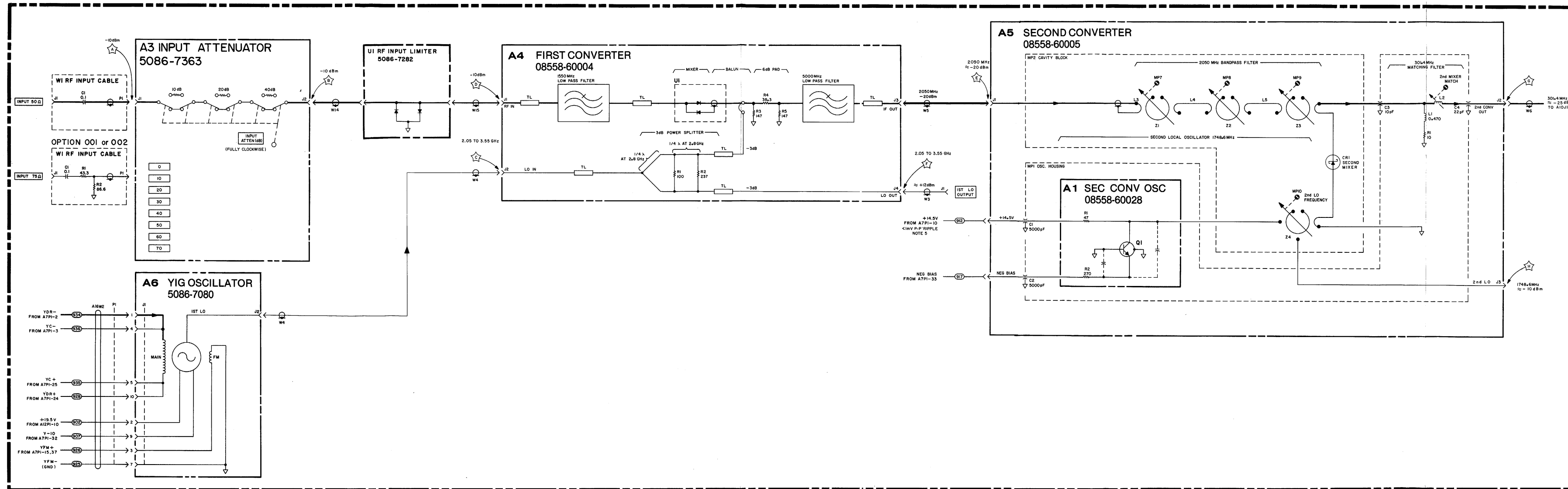

- NOTES
1. REFERENCE DESIGNATORS WITHIN ASSEMBLIES ARE ABBREVIATED. PREFIX ABBREVIATION WITH ASSEMBLY NUMBER FOR COMPLETE REFERENCE DESIGNATOR.
 2. UNLESS OTHERWISE INDICATED: RESISTANCE IN OHMS (Ω) CAPACITANCE IN MICROFARADS (μF) INDUCTANCE IN MICROHENRIES (μH)
 3. REFER TO FIGURE 8-2 FOR MEASUREMENT CONDITIONS.
 4. TRANSMISSION LINES ARE SHOWN AS FOLLOWS:
TL
 5. RIPPLE MEASURED WITH SWEEP TIME/DIV CONTROL SET TO MAN.

**A3, A4,
A5, A6**

Figure 8-18. A3 Input Attenuator, A4 First Converter, A5 Second Converter and A6 YIG Oscillator, Schematic

8-35/8-36 (blank)

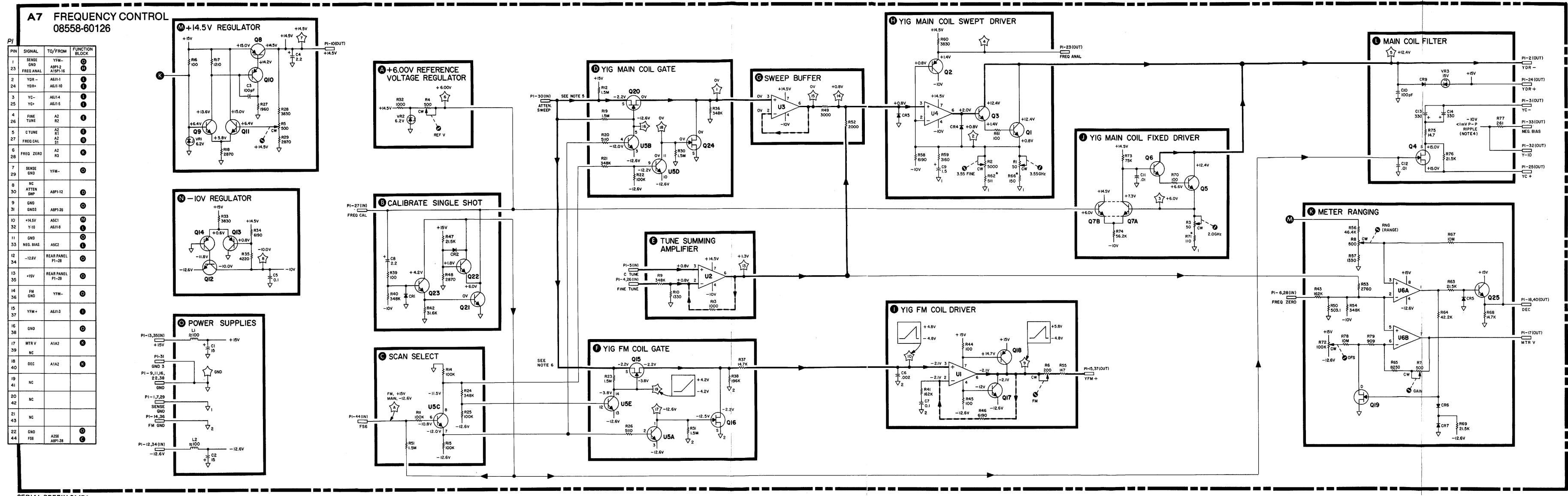

SERIAL PREFIX 2147A

NOTES

- REFERENCE DESIGNATORS WITHIN THIS ASSEMBLY ARE ABBREVIATED. PREFIX ABBREVIATION WITH ASSEMBLY NUMBER FOR COMPLETE REFERENCE DESIGNATOR.
- UNLESS OTHERWISE INDICATED: RESISTANCE IN OHMS (Ω) CAPACITANCE IN MICROFARADS (μF) INDUCTANCE IN MICROHENRIES (μH)
- REFER TO FIGURE 8-2 FOR MEASUREMENT CONDITIONS.
- RIPPLE MEASURED WITH SWEEP DIV CONTROL SET TO MAN.
- SIGNAL PATH FOR FREQ SPAN DIV CONTROL SETTINGS OF 2 MHz OR GREATER.
- SIGNAL PATH FOR FREQ SPAN DIV CONTROL SETTINGS OF 1MHz OR LESS
- TRANSISTOR AND IC PIN DIAGRAMS (TOP VIEW):

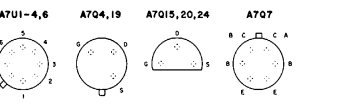

8. MNEMONIC TABLE:

MNEMONIC	DESCRIPTION
DEC	DECIMAL POINT LINE (LOW-OFF)
FM GND	FM COIL DRIVER GROUND (TO GND, YFM- ON YIG)
FS6	YIG MAIN/FM COIL CONTROL LINE
GND3	GROUND (TO A8 SWEEP GENERATOR)
MTR V	DPM VOLTAGE
Y-10	YIG -10V
YC-	YIG COIL SIGNAL
YDR-	YIG MAIN COIL SIGNAL
YFM-	YIG FM COIL SIGNAL (YFM- TO GND, SENSE GND)

FOR COMPLETE LIST OF SIGNAL NAMES AND MNEMONICS, SEE A16 MOTHERBOARD SCHEMATIC.

A7

Figure 8-20. A7 Frequency Control, Schematic

8-43/8-44 (blank)

SWEEP GENERATOR
08558-60123

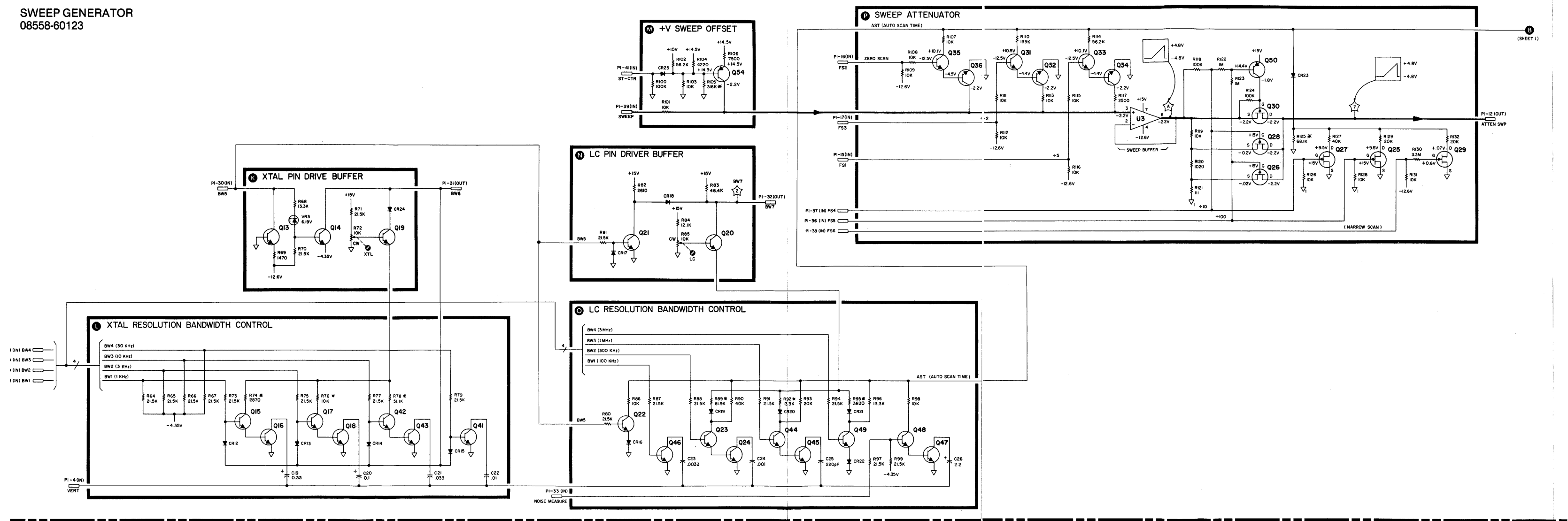

NOTES

1. REFERENCE DESIGNATORS WITHIN THIS ASSEMBLY ARE ABBREVIATED, PREFIX ABBREVIATION WITH ASSEMBLY NUMBER FOR COMPLETE REFERENCE DESIGNATOR.
2. UNLESS OTHERWISE INDICATED: RESISTANCE IN OHMS (Ω) CAPACITANCE IN MICROFARADS (μ F) INDUCTANCE IN MICROHENRIES (μ H)
3. REFER TO FIGURE 8-2 FOR MEASUREMENT CONDITIONS.

4. BW CONTROL LINE TYPICAL VOLTAGES:

RESOLUTION BANDWIDTH	MODE XTAL OR LC	BW CONTROL LINE TYPICAL VOLTAGES						
		BW1	BW2	BW3	BW4	BW5	BW6	BW7
3 MHz	LC	-4	-4	-4	+15	+15	-4	+7
1 MHz	LC	-4	-4	+15	-4	+15	-4	+9
300 KHz	LC	-4	+15	-4	-4	+15	-4	+10
100 KHz	LC	+15	-4	-4	-4	+15	-4	+14
30 KHz	XTAL	-4	-4	-4	+15	-5	+10	+12
10 KHz	XTAL	-4	-4	+15	-4	-5	+10	+14
3 KHz	XTAL	-4	+15	-4	-4	-5	+9	+14
1 KHz	XTAL	+15	-4	-4	-4	-5	+7	+15

5. IC AND FET PIN CONFIGURATIONS (TOP VIEW):

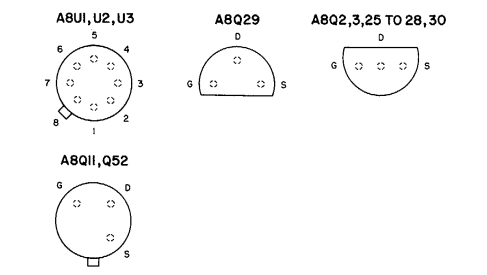

6. A8MP1 IS A THERMAL LINK. A8Q7 PROVIDES TEMPERATURE COMPENSATION FOR A8Q4.

7. A8Q5 IS A 1 mA CURRENT LIMITER.

8. REFER TO SHEET 1 FOR MNEMONIC TABLE.

A8

Figure 8-23. A8 Sweep Generator, Schematic (2 of 2)

8-55/8-56 (blank)

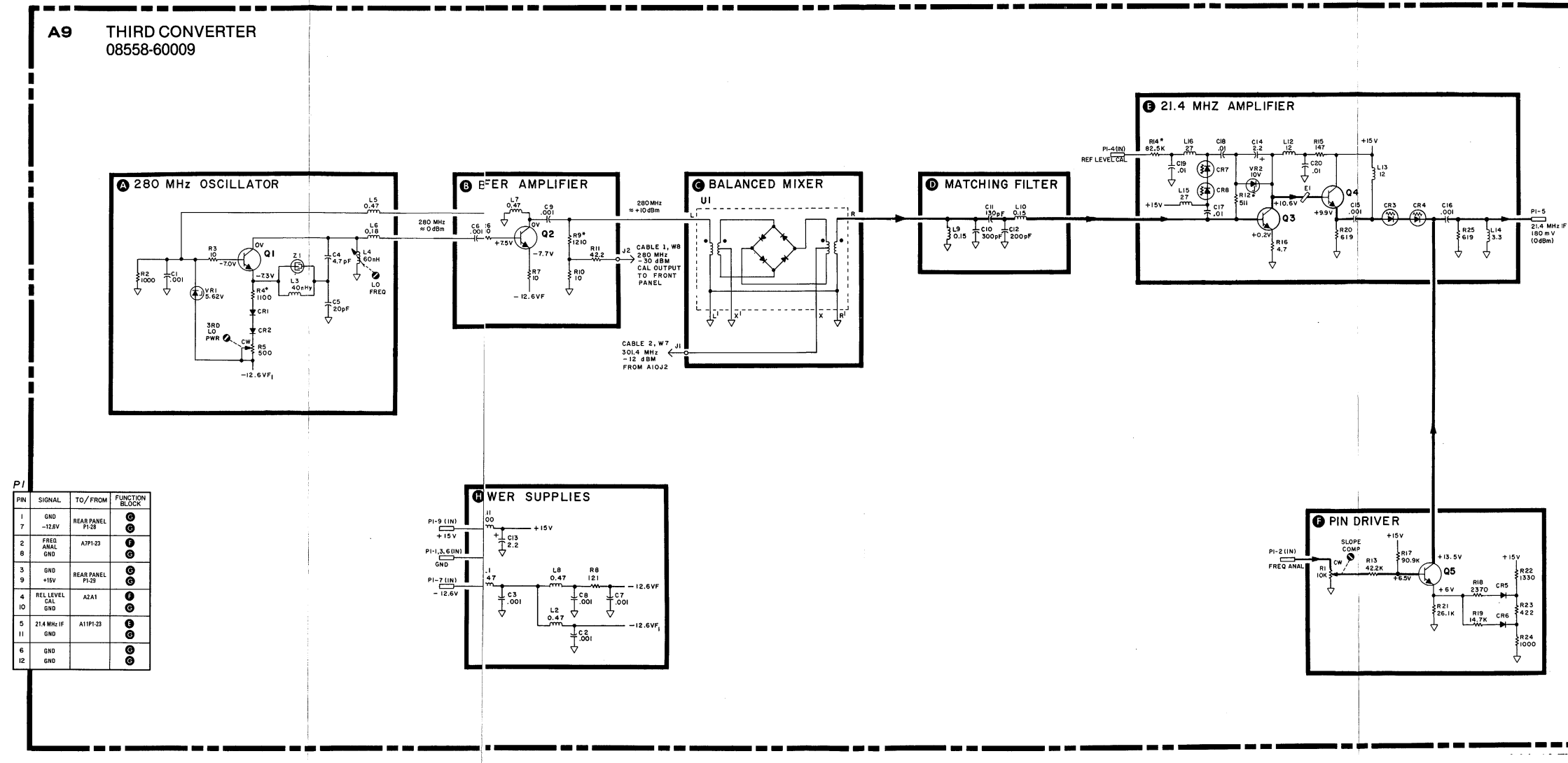
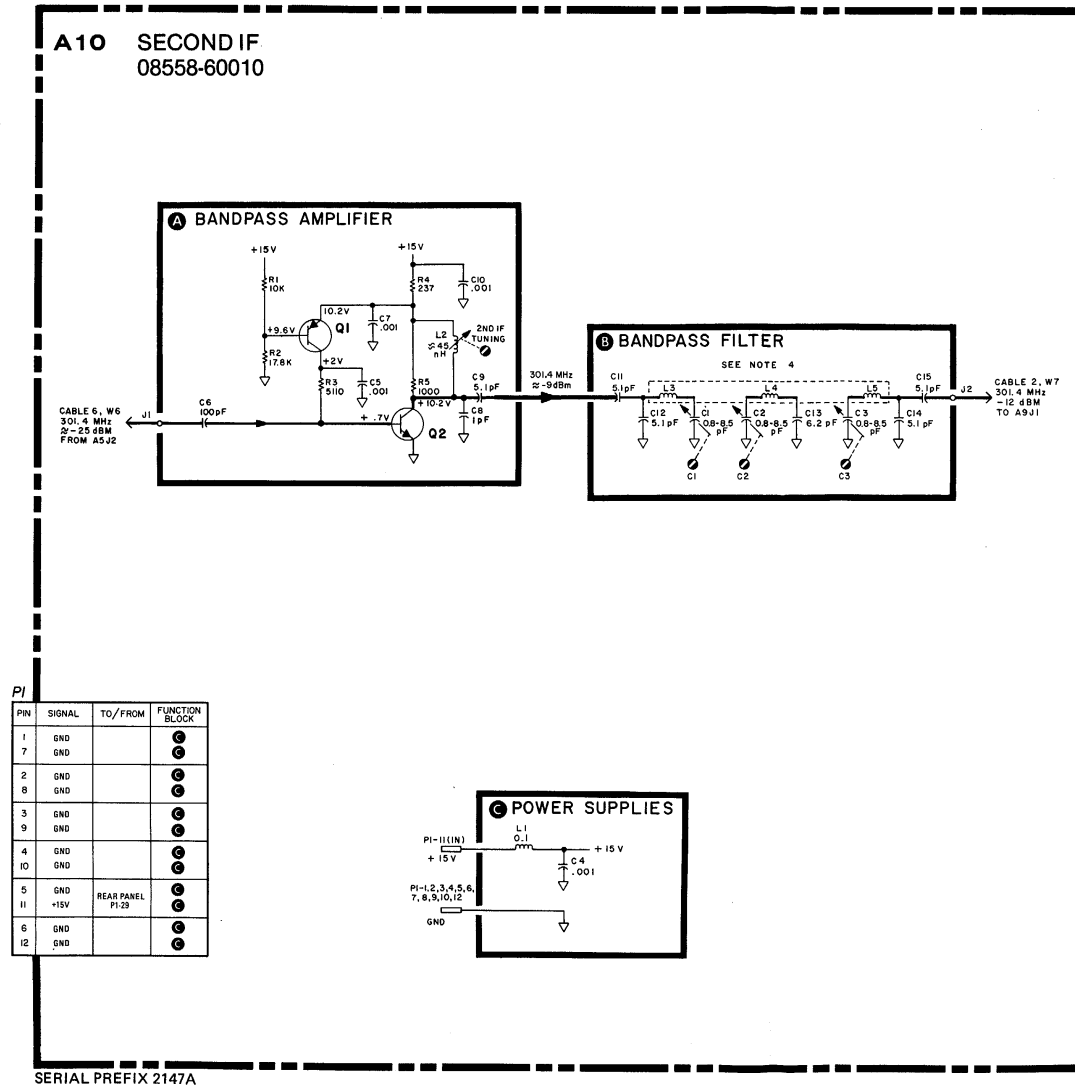

- NOTES
1. REFERENCE DESIGNATORS WITHIN THIS ASSEMBLY ARE ABBREVIATED. PREFIX ABBREVIATION WITH ASSEMBLY NUMBER FOR COMPLETE REFERENCE DESIGNATOR.
 2. UNLESS OTHERWISE INDICATED: RESISTANCE IN OHMS (Ω) CAPACITANCE IN MICROFARADS (μ F) INDUCTANCE IN MICROHENRIES (μ H)
 3. REFER TO FIGURE 8-2 FOR MEASUREMENT CONDITIONS.
 4. A10L3, L4, AND L5 ARE ON SAME COIL FORM (NOT SEPARATELY REPLACEABLE).
 5. MNEMONIC TABLE:
- | MNEMONIC | DESCRIPTION |
|---------------|-------------------------------------|
| FREQ ANAL | FREQUENCY ANALOG VOLTAGE |
| REL LEVEL CAL | REFERENCE LEVEL CALIBRATION VOLTAGE |
- FOR COMPLETE LIST OF SIGNAL NAMES AND MNEMONICS, SEE A16 MOTHERBOARD SCHEMATIC.

A9, A10

Figure 8-26. A9 Third Converter and A10 Second IF, Schematic

8-61/8-62 (blank)

A11 BANDWIDTH FILTER NO. 1
08558-60128

PIN	SIGNAL	TO/FROM	FUNCTION BLOCK
1	GND		1
23	21.4 MHz IF	ASPI-5	1
24	GND		1
25	NC		1
3	GND		1
4	NC		1
5	GND	REAR PANEL P1-23	1
6	+15V		1
7	GND		1
29	+10V NOM	ASPI-7,29	1
8	GND	A2	1
30	BW5	ASPI-30	1
9	GND		1
31	BW6	ASPI-31	1
10	GND		1
32	BW7	ASPI-32	1
11	GND		1
33	NC		1
12	GND		1
34	NC		1
13	GND		1
35	NC		1
14	GND		1
36	NC		1
15	GND		1
37	NC		1
16	GND		1
38	NC		1
17	GND		1
39	NC		1
18	GND		1
40	NC		1
19	GND		1
41	NC		1
20	GND		1
42	NC		1
21	GND		1
43	NC		1
22	21.4 MHz IF	A12P1-44	1
44	NC		1

SERIAL PREFIX: 2147A

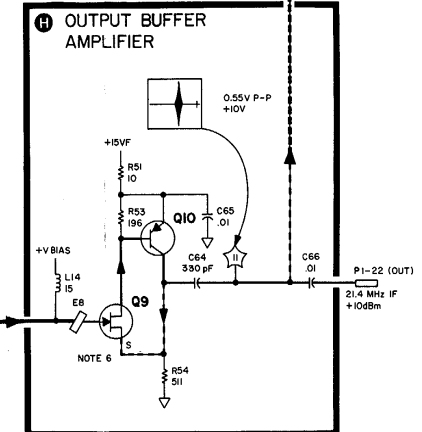
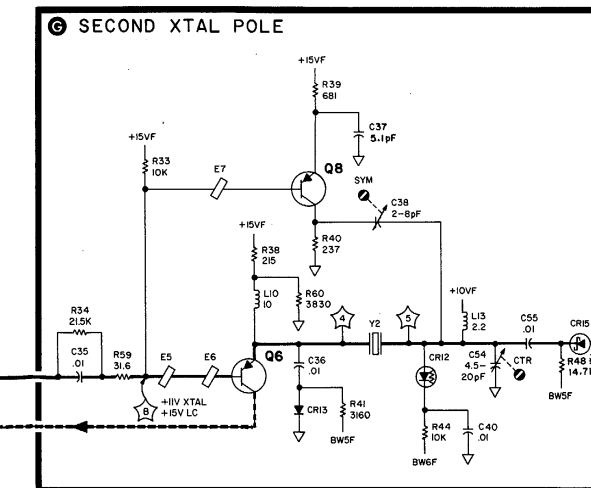
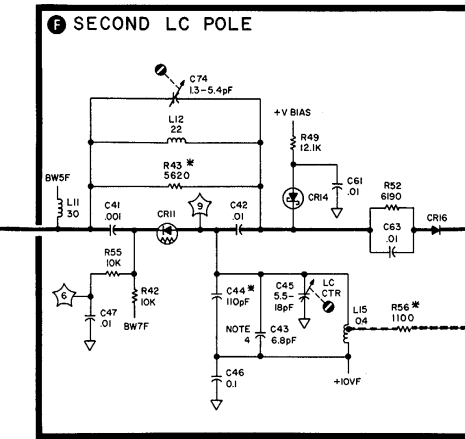
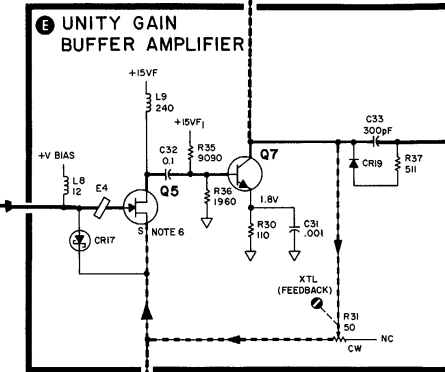
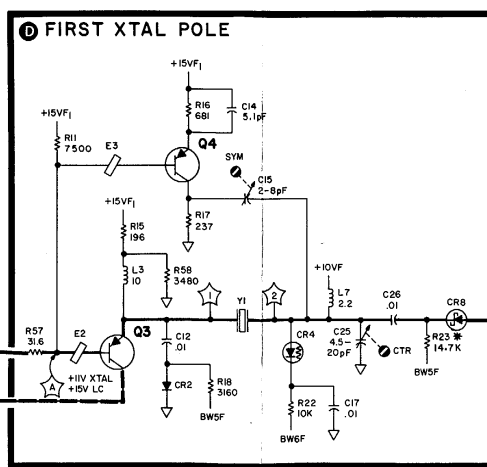
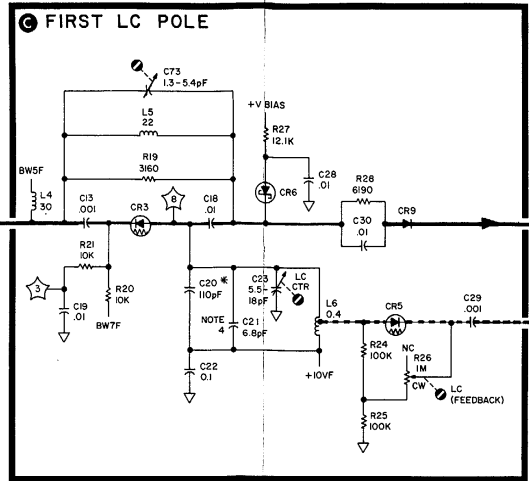
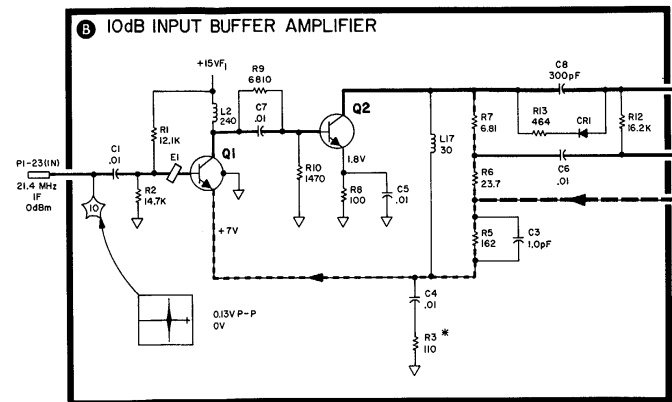
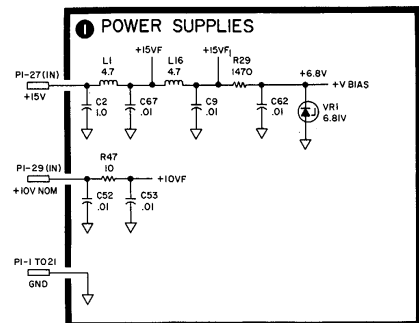
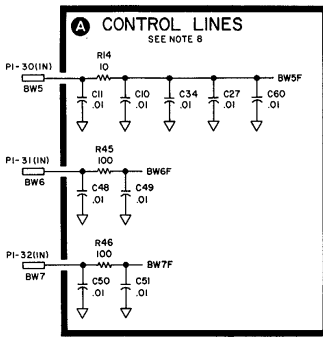

NOTES

1. REFERENCE DESIGNATORS WITHIN THIS ASSEMBLY ARE ABBREVIATED, PREFIX ABBREVIATION WITH ASSEMBLY NUMBER FOR COMPLETE REFERENCE DESIGNATOR.
2. UNLESS OTHERWISE INDICATED: RESISTANCE IN OHMS (Ω) CAPACITANCE IN MICROFARADS (μF) INDUCTANCE IN MICROHENRIES (μH)
3. REFER TO FIGURE 8-2 FOR MEASUREMENT CONDITIONS.
4. TEMPERATURE COMPENSATING CAPACITOR.
5. ASTERISK (*) DENOTES FACTORY SELECTED COMPONENT. NOMINAL VALUE IS SHOWN.
6. SOURCE VOLTAGE SHOULD BE 0.2V TO 1.5V GREATER THAN THE GATE VOLTAGE.
7. VOLTAGES SHOULD BE MEASURED WITH 1KΩ OR GREATER AT PROBE TIP TO PREVENT OSCILLATION AND ERRONEOUS READINGS.

BANDWIDTH	BW CONTROL LINES TYPICAL VOLTAGES	BW	
		XTAL	LC
3 MHz	+15	-4	+7
1 MHz	+15	-4	+9
300 kHz	+15	-4	+10
100 kHz	+15	-4	+12
30 kHz	+15	+10	+14
10 kHz	-5	+10	+14
3 kHz	-5	+9	+14
1 kHz	-5	+7	+15

9. ⚡ DESIGNATES SHIELDING BEAD.

Figure 8-30. A11 Bandwidth Filter No. 1, Schematic

8-69/8-70 (blank)

A11

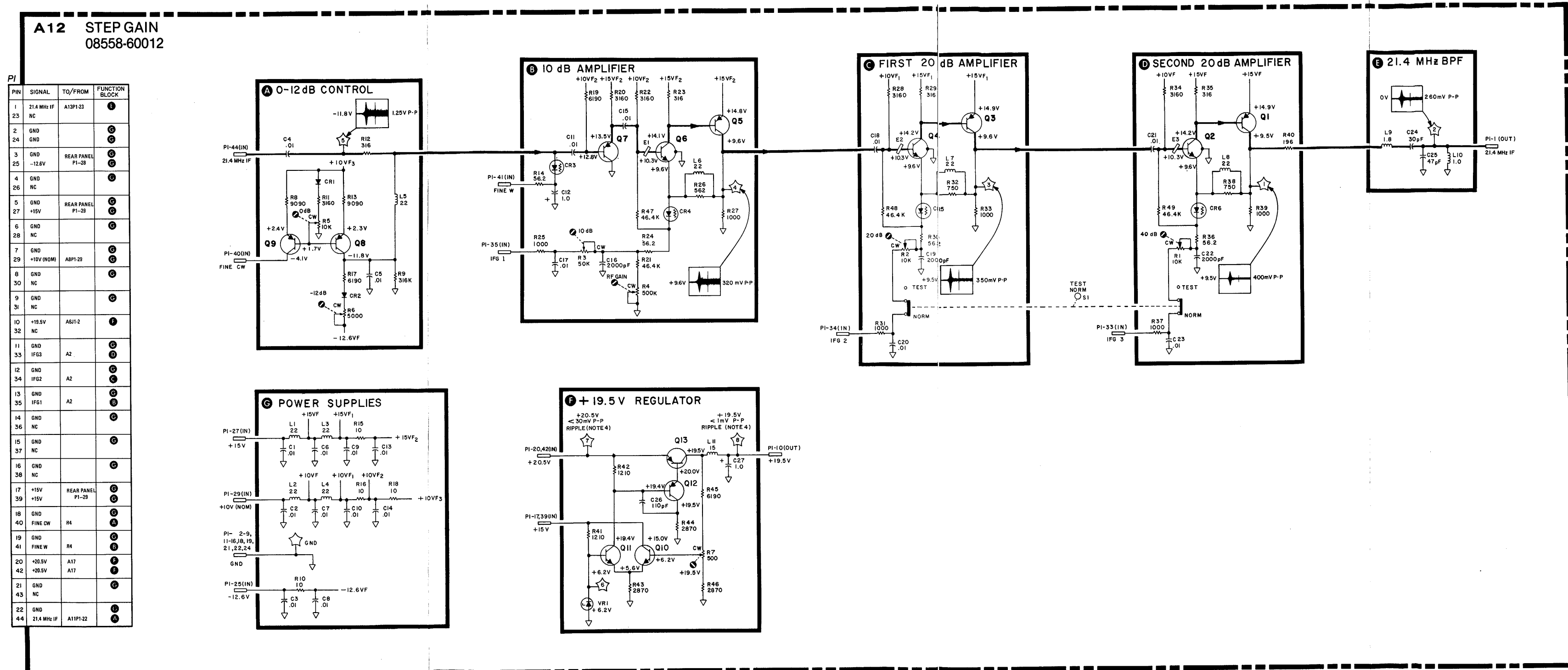

PIN	SIGNAL	TO/FROM	FUNCTION BLOCK
1	21.4 MHz IF	A13P1-23	(A)
2	GND		(C)
23	NC		(C)
24	GND		(C)
25	-12.6V	REAR PANEL P1-28	(C)
26	GND		(C)
27	+15V	REAR PANEL P1-28	(C)
28	GND		(C)
29	+10V (NOM)	ASPI-28	(C)
30	GND		(C)
31	NC		(C)
32	+19.5V	ASJ1-2	(F)
33	GND	IFG3	(B)
34	GND	IFG2	(B)
35	GND	IFG1	(B)
36	GND		(C)
37	GND		(C)
38	GND		(C)
39	+15V	REAR PANEL P1-28	(C)
40	GND	FINE CW	(A)
41	GND	FINE W	(A)
42	+20.5V	A17	(F)
43	GND		(C)
44	21.4 MHz IF	A11P1-22	(A)

- NOTES**
1. REFERENCE DESIGNATORS WITHIN THIS ASSEMBLY ARE ABBREVIATED, PREFIX ABBREVIATION WITH ASSEMBLY NUMBER FOR COMPLETE REFERENCE DESIGNATOR.
 2. UNLESS OTHERWISE INDICATED: RESISTANCE IN OHMS (Ω) CAPACITANCE IN MICROFARADS (μ F) INDUCTANCE IN MICROHENRIES (μ H)
 3. SEE FIGURE 8-2 FOR MEASUREMENT CONDITIONS.
 4. RIPPLE MEASURED WITH SWEEP TIME/DIV CONTROL SET TO MAN.
 5. MNEMONIC TABLE:
- | MNEMONIC | DEFINITION |
|----------|---|
| FINE CW | REF LEVEL FINE REFERENCE VOLTAGE (CW END OF R4) |
| FINE W | REF LEVEL FINE VOLTAGE (WIPER OF R4) |
| IFG1-3 | IF GAIN CONTROL LINES |

SERIAL PREFIX: 2147A

A12

Figure 8-33. A12 Step Gain, Schematic

8-75/8-76 (blank)

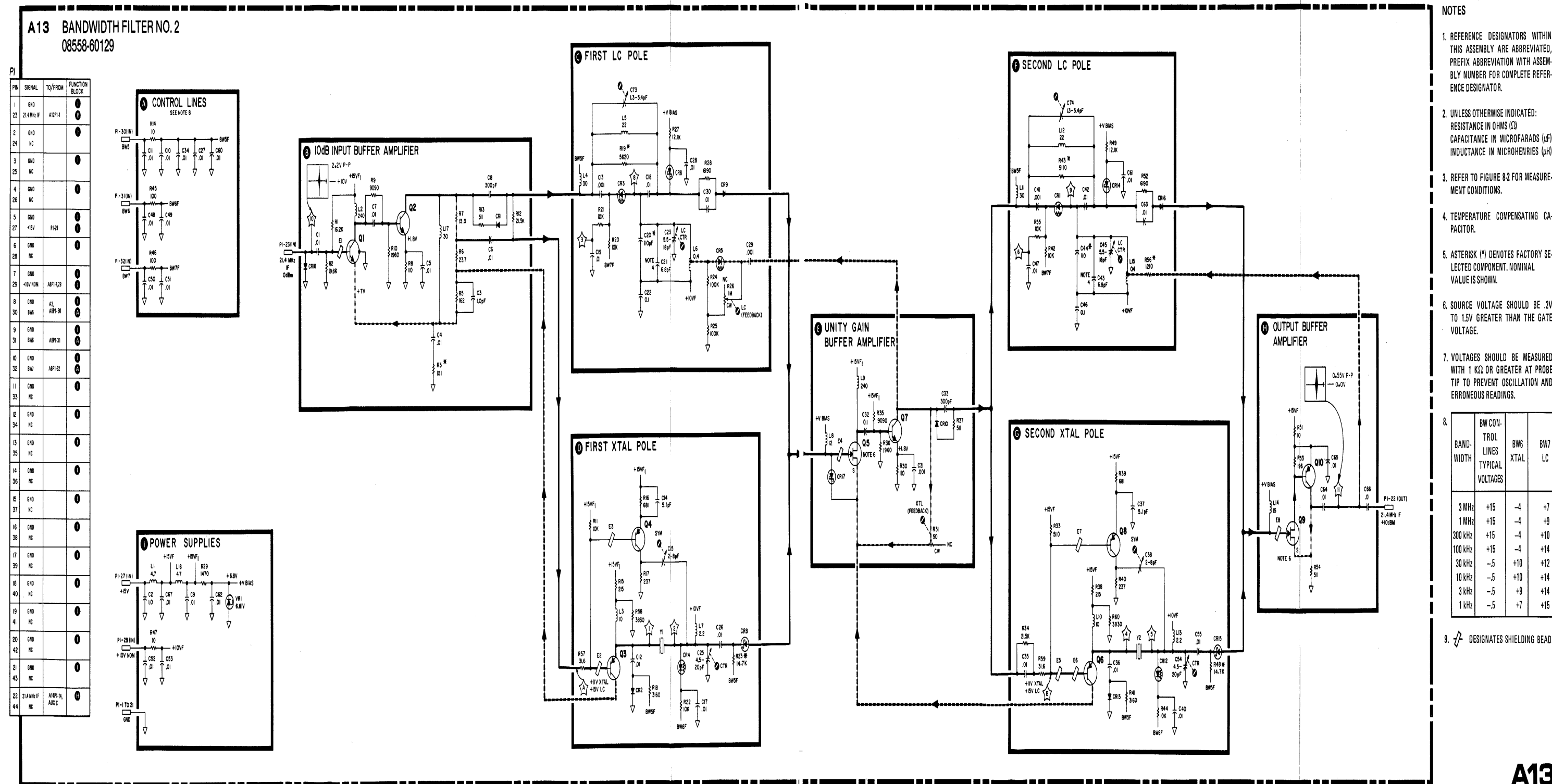

A13

Figure 8-35. A13 Bandwidth Filter No. 2, Schematic

8-79/8-80 (blank)

Model 8558B

A14 LOG AMPLIFIER ASSEMBLY
5061-5411

PIN	SIGNAL	TO/FROM	FUNCTION BLOCK
1	DND		
2	VREF	A7	
3	DND		
4	DND		
5	DND		
6	DND		
7	DND		
8	-10V	A24	
9	DND		
10	DND		
11	DND		
12	DND		
13	DND		
14	DND		
15	DND		
16	DND		
17	DND		
18	DND		
19	DND		
20	DND		
21	DND		
22	DND		
23	DND		
24	DND		
25	-10V	P13	
26	DND		
27	+10V	P13	
28	DND		
29	DND		
30	DND		
31	DND		
32	DND		
33	DND		
34	DND		
35	DND		
36	DND		
37	DND		
38	DND		
39	DND		
40	DND		
41	DND		
42	DND		
43	DND		
44	DND		

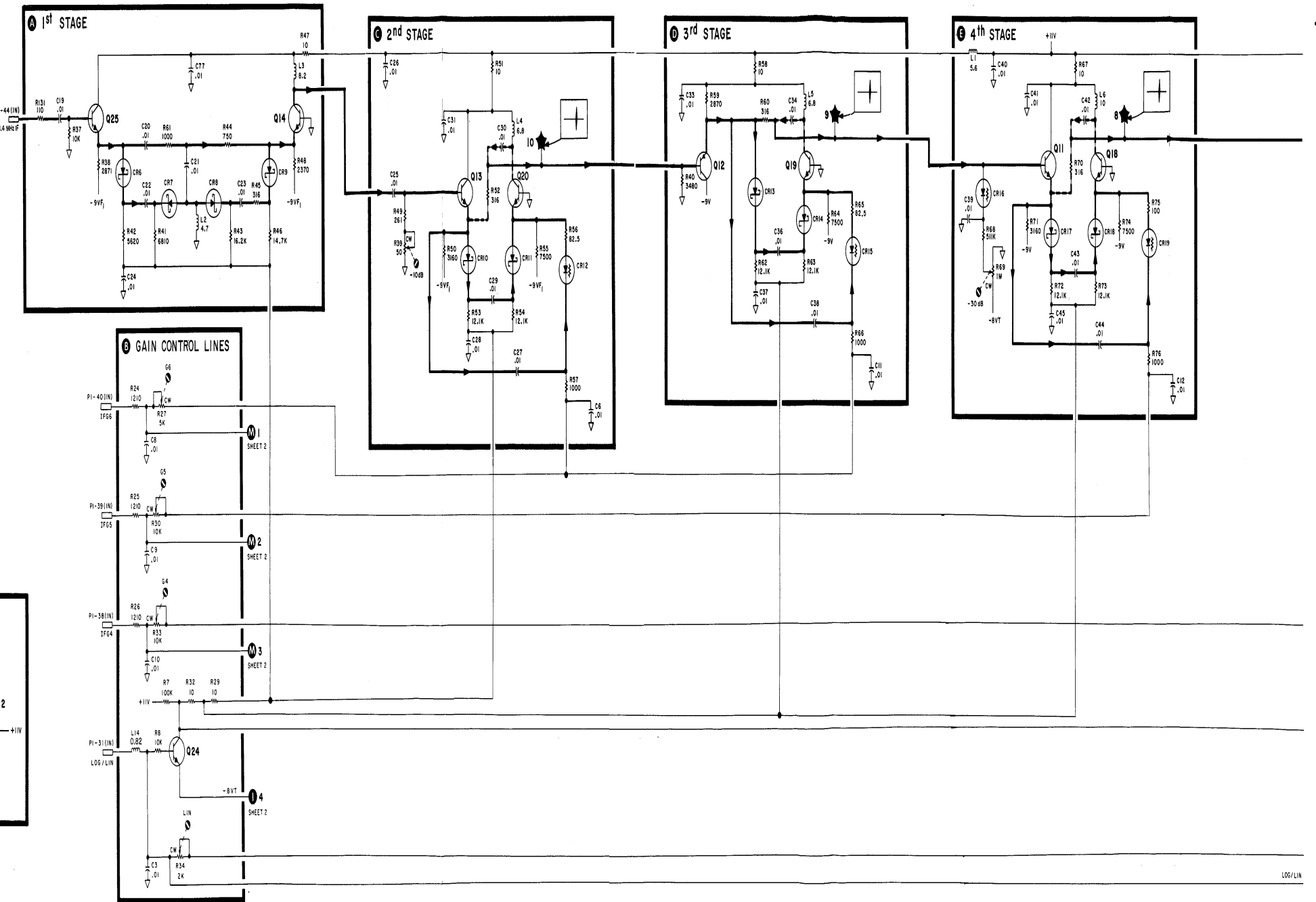
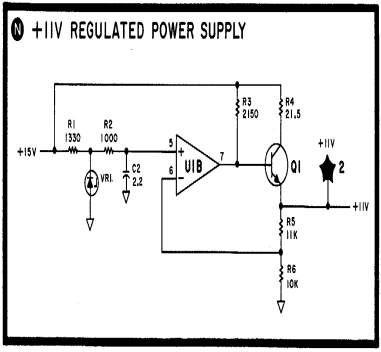
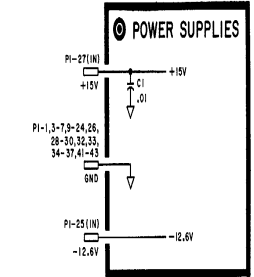

A14

SERIAL PREFIX: 2147A

SERIAL PREFIX: 2147A

Figure 8-38. A14 Log Amplifier Assembly, Schematic (1 of 2)

8-85/8-86 (blank)

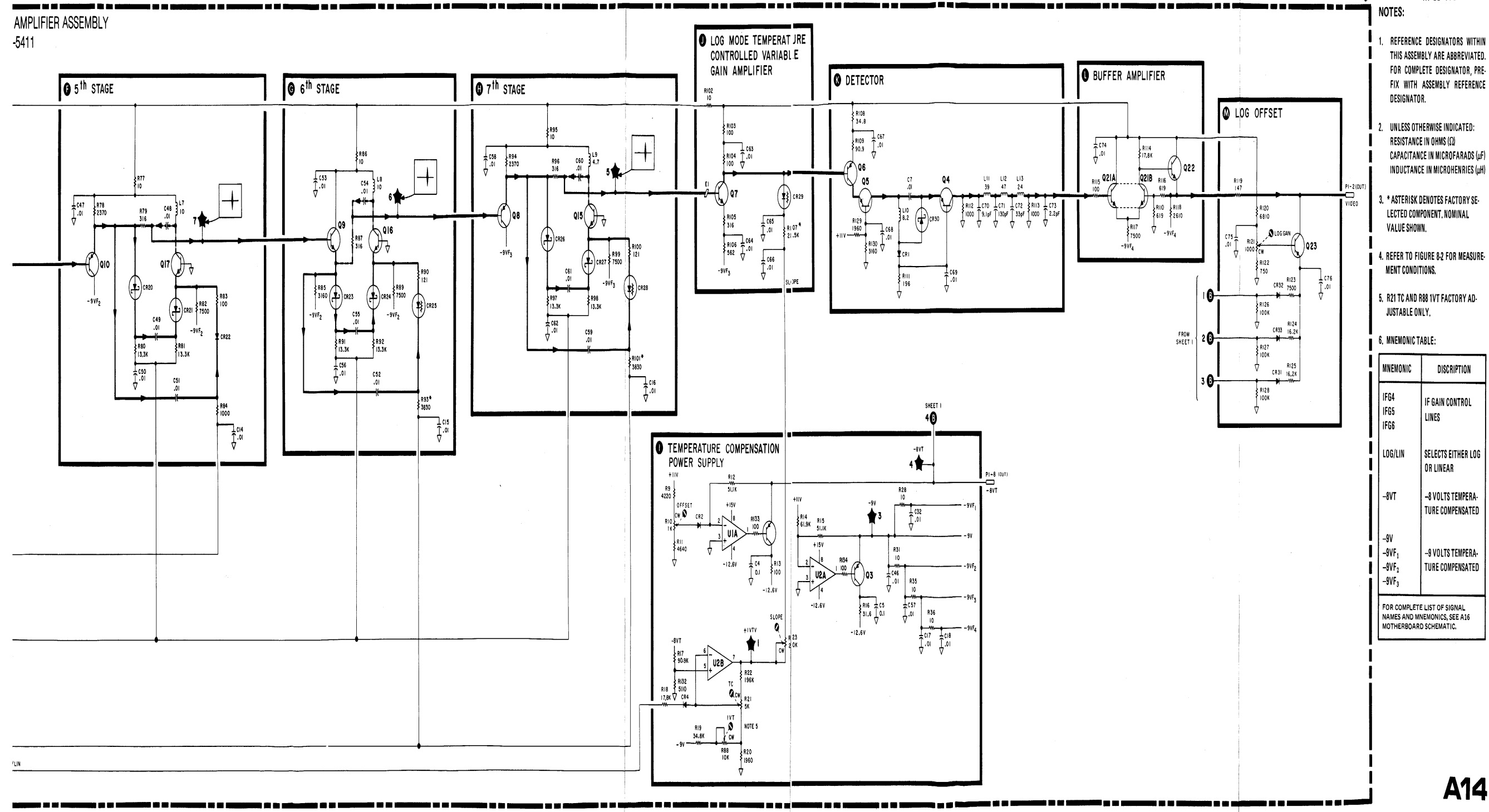

Figure 8-38. A14 Log Amplifier Assembly, Schematic (2 of 2)

8-87/8-88 (blank)

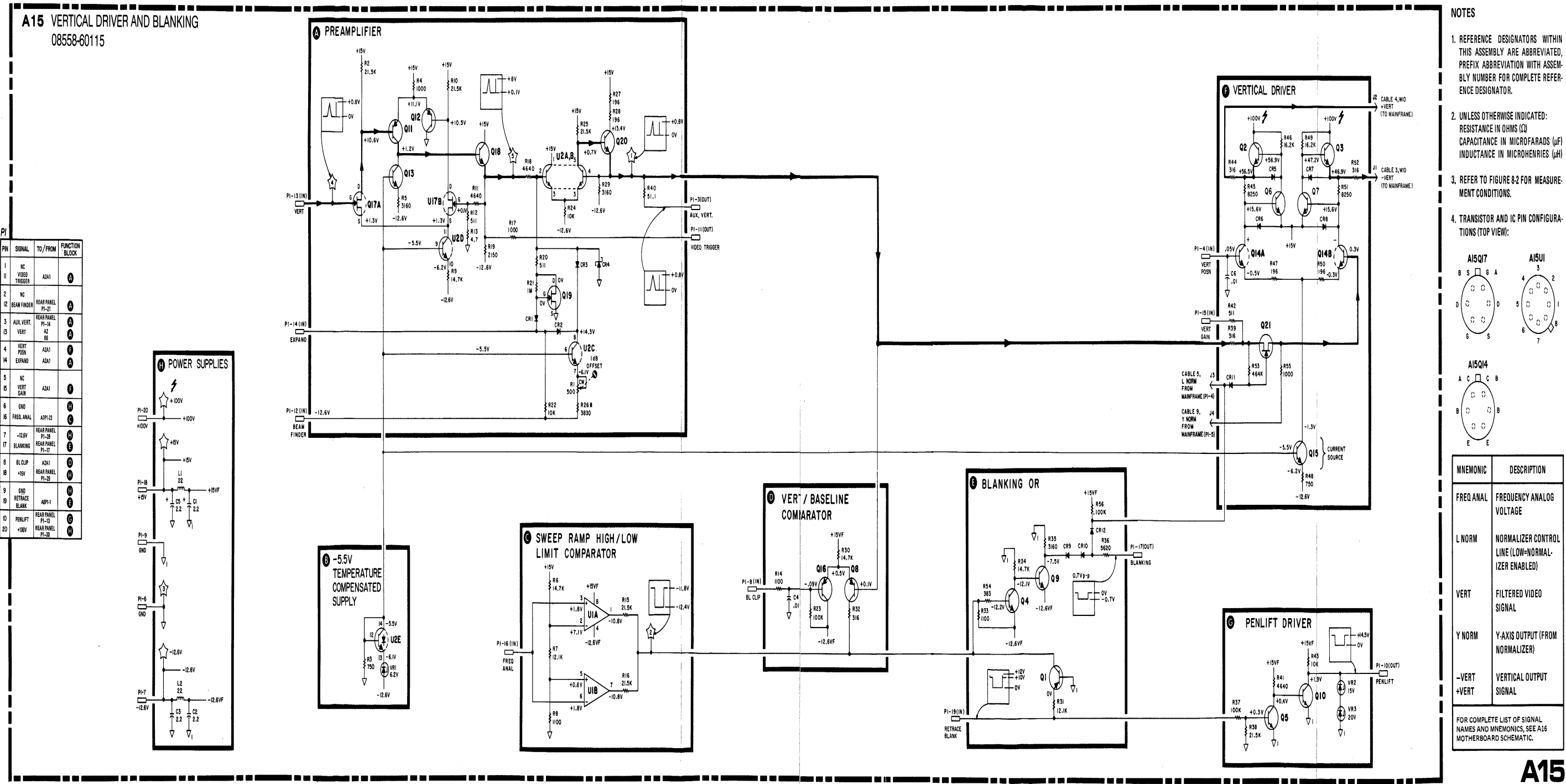

Figure 8-42. A15 Vertical driver and Blanking, Schematic

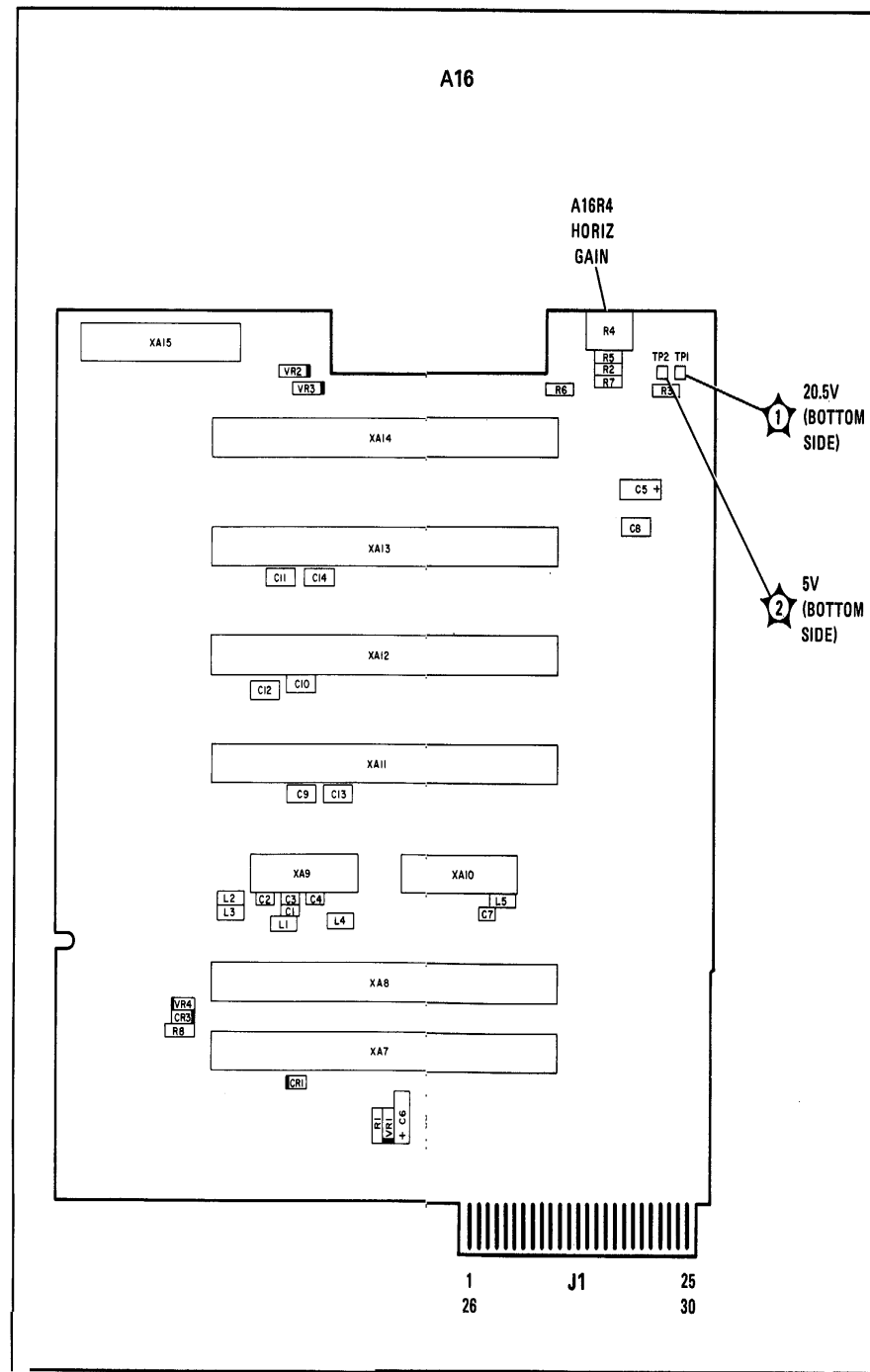

Figure 8-43. A16 Motherboard Assembly, Components and Test Point Locations

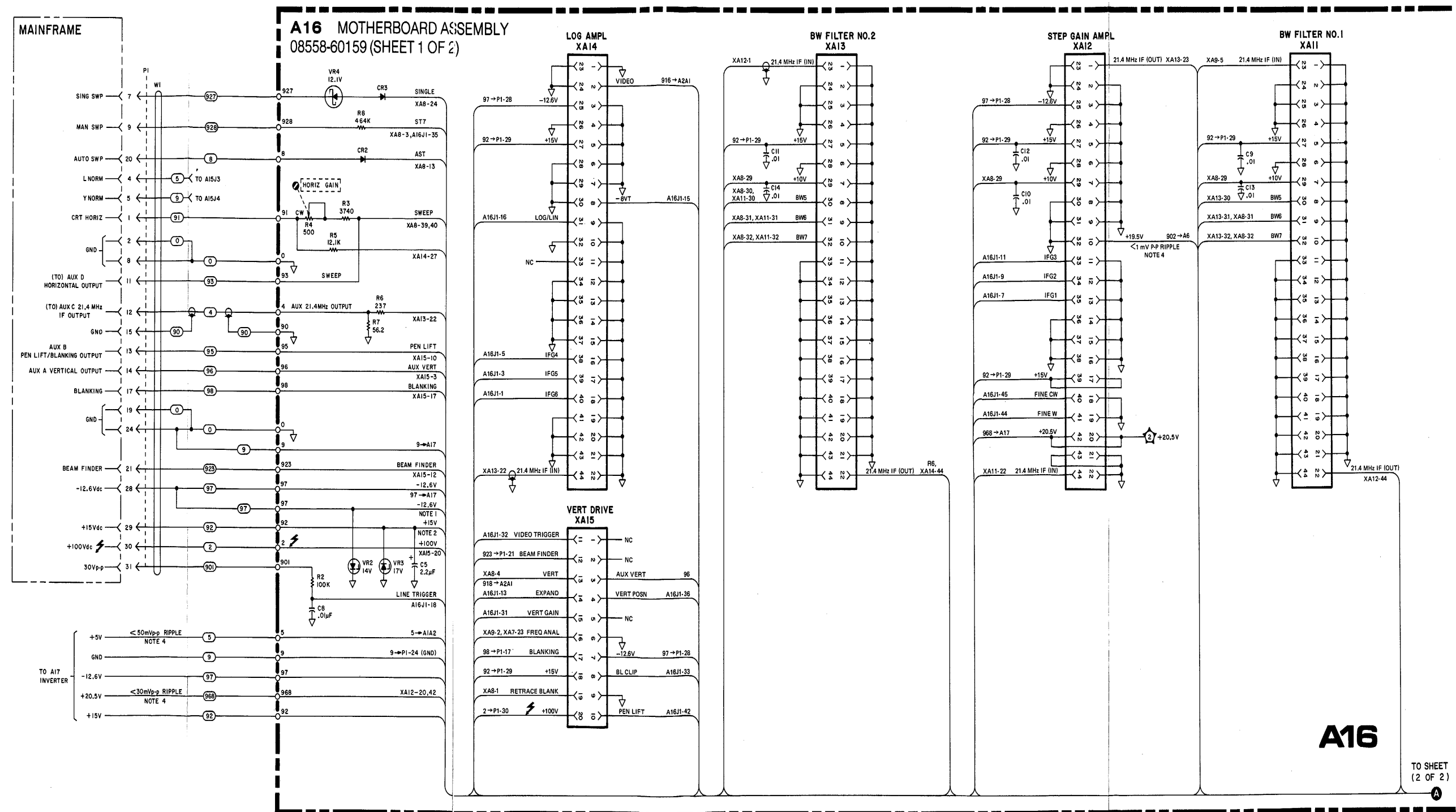
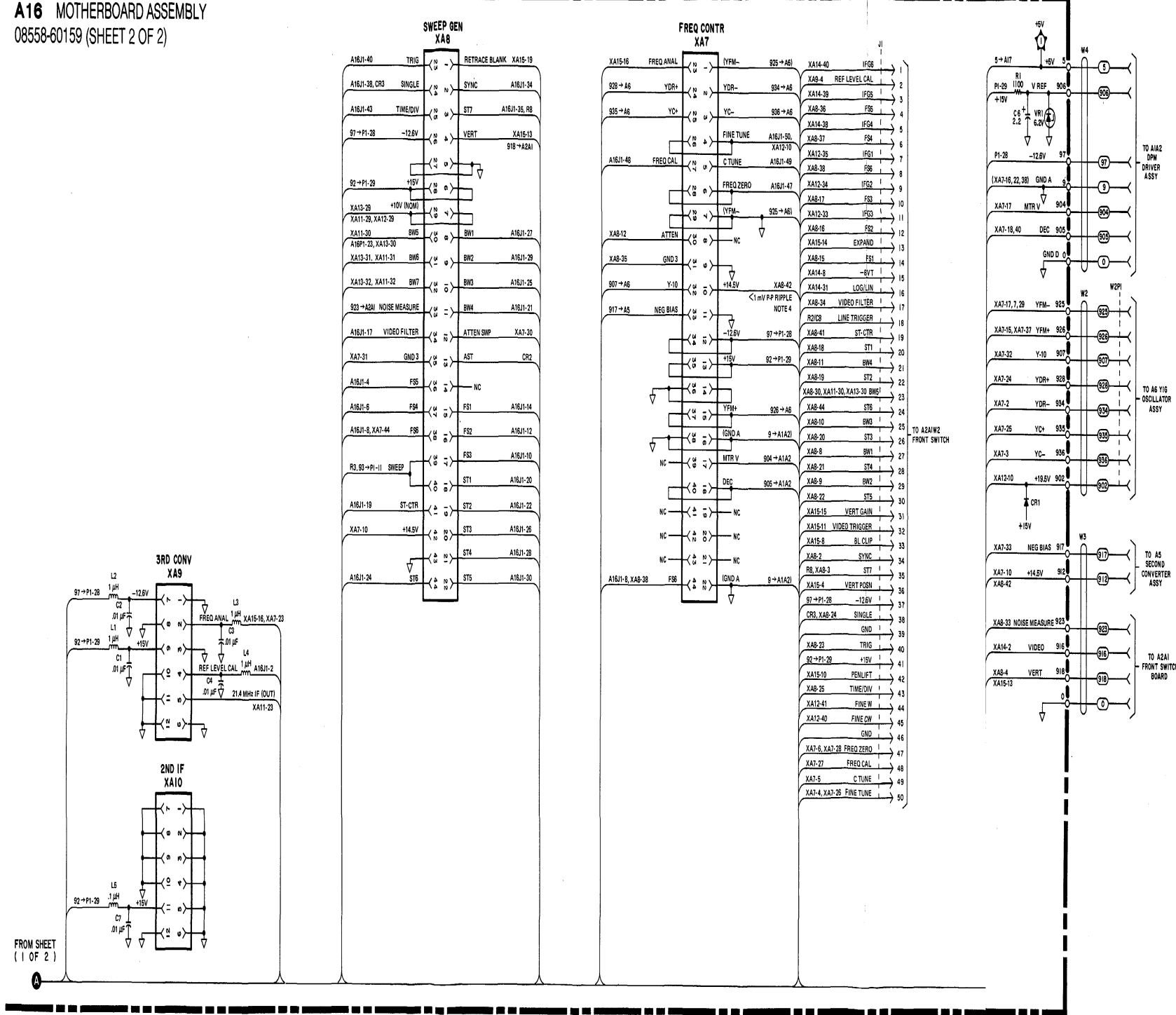

Figure 8-44. A16 Motherboard, Schematic Diagram (1 of 2)

A16 MOTHERBOARD ASSEMBLY
08558-60159 (SHEET 2 OF 2)



NOTES

1. THE -12.6V AT THIS POINT GOES TO THE FOLLOWING LOCATIONS:
A16J-37, XA7-12, XA7-34, XA8-26, XA9-7 (FILTERED), XA12-25, XA14-25, XA15-7, 97 → A17 AND 97 → A1A2.
2. THE +15V AT THIS POINT GOES TO THE FOLLOWING LOCATIONS:
A16J-41, XA7-13, XA7-35, XA8-6, XA8-28, XA9-9 (FILTERED), XA10-11 (FILTERED), XA11-27, XA12-17, XA12-27, XA12-39, XA13-27, XA14-27, XA15-18, 92 → A17, AND R1.
3. REFERENCE DESIGNATORS WITHIN THIS ASSEMBLY ARE ABBREVIATED. FOR COMPLETE DESIGNATOR, PREFIX WITH ASSEMBLY REFERENCE DESIGNATOR.
4. RIPPLE MEASURED WITH SWEEP TIME/DIV CONTROL SET TO MAN.
5. FROM/TO DESIGNATIONS FOR A16W1F1 ARE SHORTENED TO P1.

A16 MOTHERBOARD SIGNAL MNEMONIC OR NAME	DESCRIPTION
AST	AUTO SCAN TIME VOLTAGE
ATTEN SWP	ATTENUATED SWEEP VOLTAGE
AUTO SWP	AUXILIARY VERTICAL OUTPUT SIGNAL (FOR FUTURE USE)
AUX VERT	AUXILIARY VERTICAL OUTPUT SIGNAL
BEAM FINDER	BEAM FINDER CONTROL LINE (LOW-OFF)
BL CLIP	BASIS CLIPPER VOLTAGE
BLANKING	CRT BLANKING SIGNAL
BW1-7	BANDWIDTH CONTROL LINES
C TUNE	COARSE TUNE VOLTAGE
DEC	DECIMAL POINT LINE (LOW-OFF)
EXPAND	1 dB/DIV CONTROL LINE (LOW-OFF)
FINE TUNE	FINE TUNE VOLTAGE
FINE CW	REF LEVEL FINE REFERENCE VOLTAGE (CW END OF A2R4)
FINE W	REF LEVEL FINE VOLTAGE (WIPER OF A2R4)
FREQ ANAL	FREQUENCY ANALOG VOLTAGE
FREQ CAL	FREQUENCY CALIBRATION CONTROL LINE (LOW-CAL)
FREQ ZERO	FREQUENCY ZERO VOLTAGE
FS1-6	FREQUENCY SPAN CONTROL LINES (FS2-ZERO SPAN, FS3-YIG MAIN/FM COIL)
GND A	DPM ANALOG GROUND
GND D	DPM DIGITAL GROUND
GND3	GROUND (FROM A7 FREQUENCY CONTROL)
IFG1-6	IF GAIN CONTROL LINES
LINE TRIGGER	+30V p-p TRIGGER SIGNAL (FROM MAINFRAME LINE POWER)
L NORM	NORMALIZER CONTROL LINE (LOW-NORMALIZER ENABLED)
LOG/LIN	LOG/LIN CONTROL LINE (LOW-LIN)
MAN SWP	(FOR FUTURE USE)
MTR V	DPM VOLTAGE
NEG BIAS	-10V (TO SECOND CONVERTER OSCILLATOR)
NOISE MEASURE	MAX VIDEO FILTER CONTROL LINE (HIGH-MAX)
PENLIFT	PENLIFT/BLANKING OUTPUT SIGNAL
REF LEVEL CAL	REFERENCE LEVEL CALIBRATION VOLTAGE
RETRACE BLANK	RETRACE BLANKING SIGNAL
SINGLE	SINGLE SWEEP CONTROL LINE (HIGH-START/STOP)
SING SWP	(FOR FUTURE USE)
ST1-7	SCAN TIME CONTROL LINES (ST5-AUTO, ST6-SLOW/FAST, ST7-MANUAL)
ST-CTR	START-CENTER CONTROL LINE (LOW-START)
SWEEP	CRT HORIZONTAL SWEEP SIGNAL
SYNC	SWEEP SYNC SIGNAL
TIME/DIV	MANUAL SWEEP VOLTAGE
TRIG	TRIGGER CONTROL LINE (HIGH-FREE RUN)
V REF	DPM REFERENCE VOLTAGE
VERT	FILTERED VIDEO SIGNAL
VERT GAIN	VERTICAL GAIN VOLTAGE
VERT POSN	VERTICAL POSITION VOLTAGE
VIDEO	VIDEO SIGNAL (BEFORE VIDEO FILTERING)
VIDEO TRIGGER	VIDEO TRIGGER SIGNAL
Y NORM	Y-AXIS OUTPUT (FROM NORMALIZER)
Y-10	YIG -10V
YC-	YIG COIL SIGNAL (-)
YC+	YIG COIL SIGNAL (+)
YDR-	YIG MAIN COIL SIGNAL (-)
YDR+	YIG MAIN COIL SIGNAL (+)
YFM-	YIG FM COIL SIGNAL (-) (TO GND, SENSE GND)
YFM+	YIG FM COIL SIGNAL (+)
-VERT	NEGATIVE VERTICAL OUTPUT SIGNAL
+VERT	POSITIVE VERTICAL OUTPUT SIGNAL
-8VT	-8 VOLTS TEMPERATURE COMPENSATED

A16

Figure 8-44. A16 Motherboard, Schematic Diagram (2 of 2)

8-99/8-100 (blank)

NOTES:

1. REFERENCE DESIGNATORS WITHIN THIS ASSEMBLY ARE ABBREVIATED, PREFIX ABBREVIATION WITH ASSEMBLY NUMBER FOR COMPLETE REFERENCE DESIGNATOR.
2. UNLESS OTHERWISE INDICATED:
RESISTANCE IN OHMS (Ω)
CAPACITANCE IN MICROFARADS (μ F)
INDUCTANCE IN MICROHENRIES (μ H)
3. SEE FIGURE 8-2 FOR MEASUREMENT CONDITIONS.
4. RIPPLE MEASURED WITH SWEEP TIME/DIV CONTROL SET TO MAN.

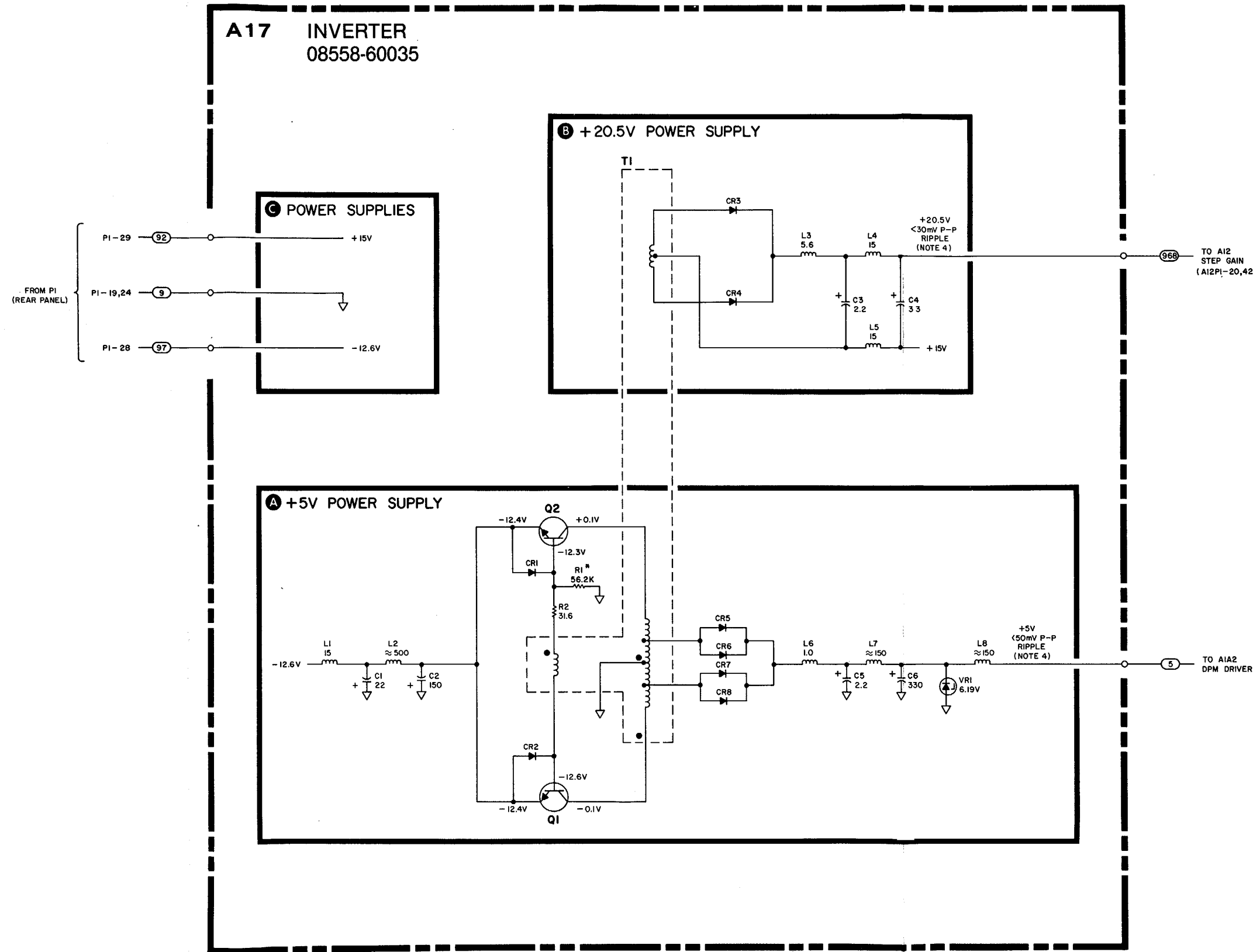

A17

Figure 8-46. A17 Inverter. Schematic

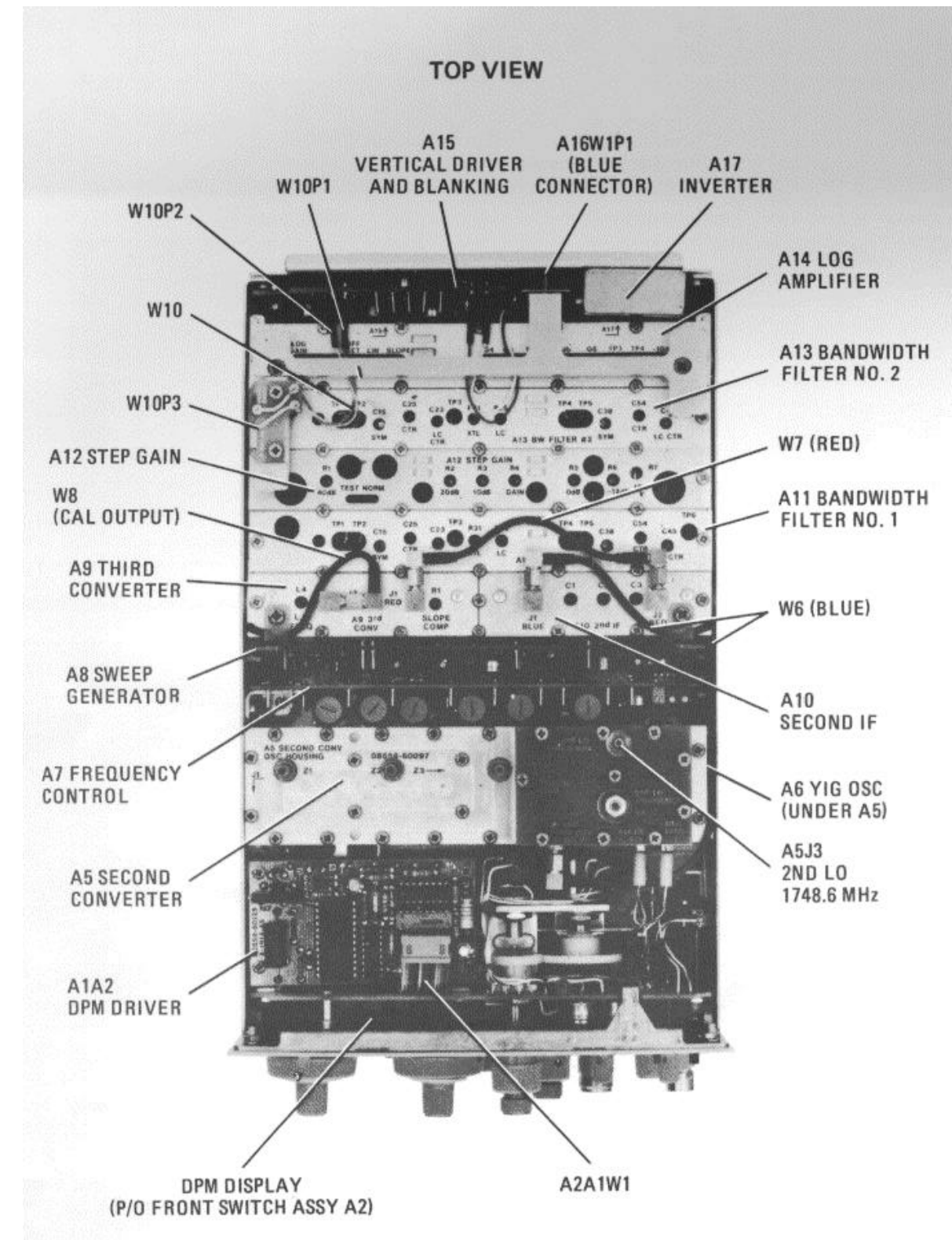
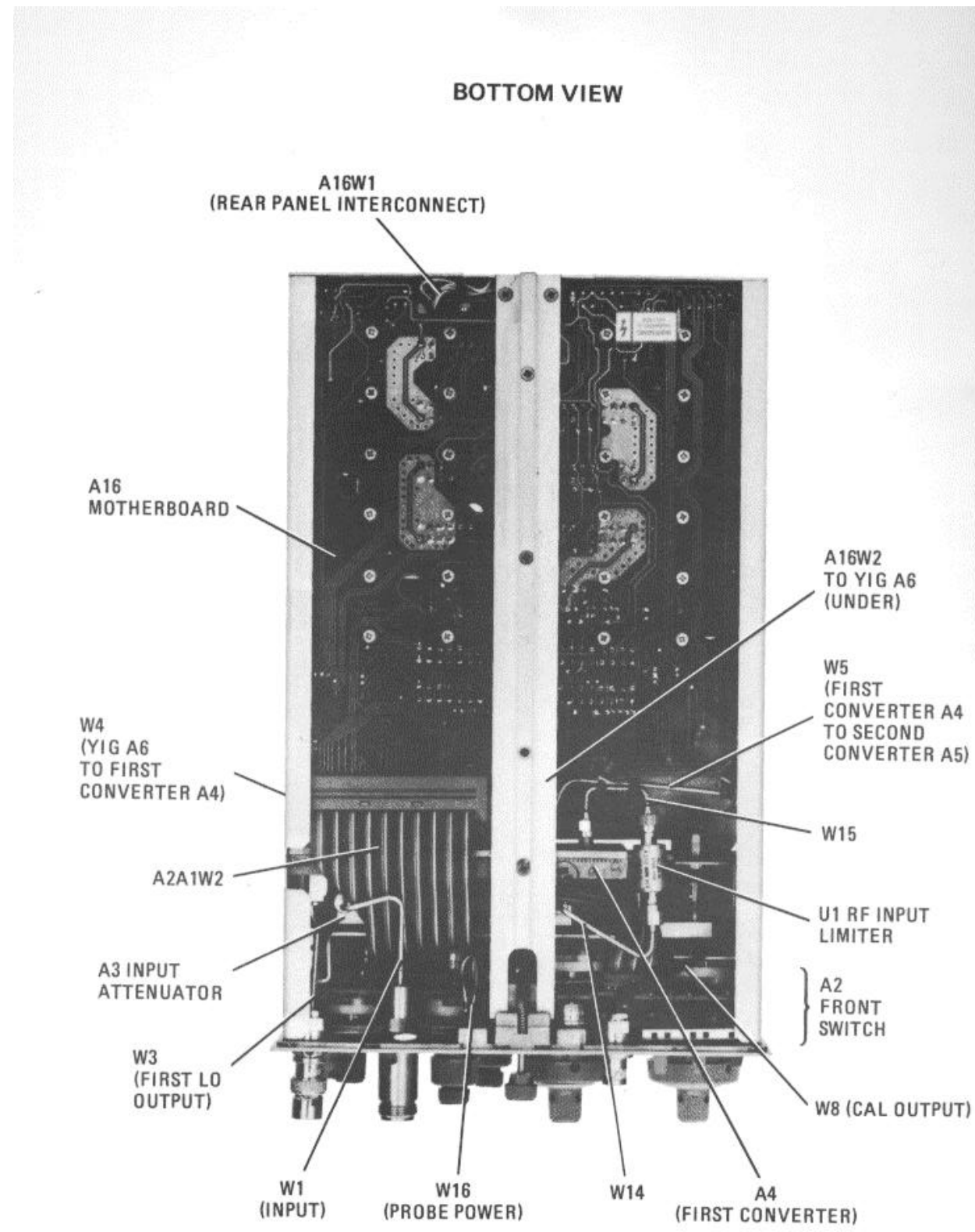

Figure 8-47. Location of Major Assemblies

RECOMMENDED CHANGES TO EQUIPMENT TECHNICAL PUBLICATIONS



THEN... JOT DOWN THE DOPE ABOUT IT ON THIS FORM, CAREFULLY TEAR IT OUT, FOLD IT AND DROP IT IN THE MAIL!

SOMETHING WRONG WITH THIS PUBLICATION?

FROM: (PRINT YOUR UNIT'S COMPLETE ADDRESS)

DATE SENT

PUBLICATION NUMBER

PUBLICATION DATE

PUBLICATION TITLE

BE EXACT... PIN-POINT WHERE IT IS

PAGE NO.

PARA-GRAPH

FIGURE NO.

TABLE NO.

IN THIS SPACE TELL WHAT IS WRONG AND WHAT SHOULD BE DONE ABOUT IT:

TEAR ALONG PERFORATED LINE

PRINTED NAME, GRADE OR TITLE, AND TELEPHONE NUMBER

SIGN HERE:

DA FORM 2028-2
1 JUL 79

PREVIOUS EDITIONS ARE OBSOLETE.

P.S.—IF YOUR OUTFIT WANTS TO KNOW ABOUT YOUR RECOMMENDATION MAKE A CARBON COPY OF THIS AND GIVE IT TO YOUR HEADQUARTERS.

PIN: 059359-000